

## Impeller with grinder system

### Operating ranges

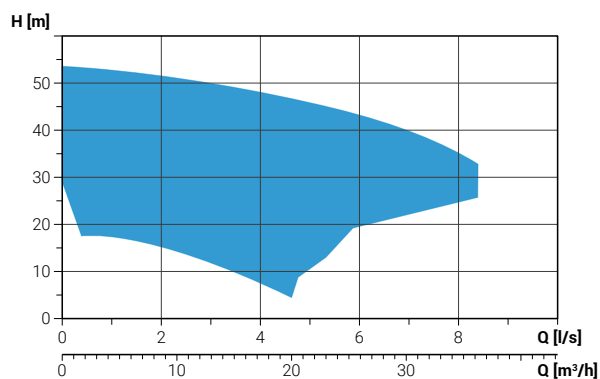

### Range characteristics

Motor power	1.8 ÷ 7.5 kW
Poles	2
Insulation class	H
Degree of protection	IP68
Discharge vertical	-
Discharge horizontal	G 1½" DN32 - G 2" DN32
Free passage	-
Max flow rate	8.4 l/s
Max head	53.7 m

### Motor

Ecological dry motor with thermal protections.

### Cable

S1RN8-F electric cable. Standard version 10 m cable length.

### Mechanical seals

Two silicon carbide (SiC) mechanical seals in oil sump.

### Applications

Designed for professional and industrial use, it is suitable for the treatment of liquids containing suspended solids or fibres.

### Installations

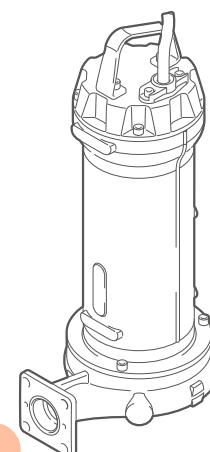
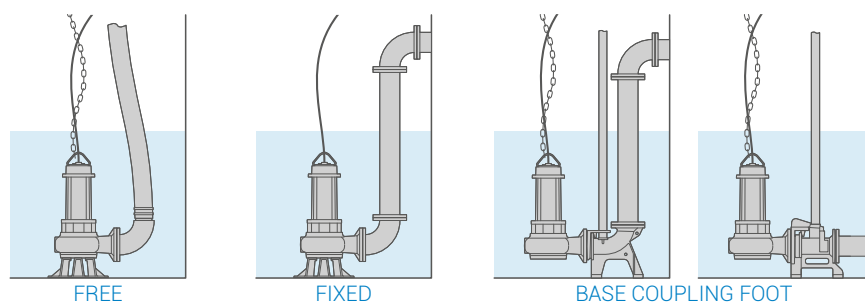

### Versions

Electrical variants	NAE, TS
Cooling system	N
Mechanical seals	2SIC

### Operating specifications

Max operating temperature	40 °C
PH of treated fluid	6 ÷ 14
Viscosity of treated fluid	1 mm²/s
Maximum immersion depth	20 m
Density of treated fluid	1 Kg/dm³
Acoustic pressure max	<70dB
Max starts per hour	30

### Construction materials

Case	Cast iron EN-GJL 250
Hydraulic parts	Cast iron EN-GJL 250
Impeller	Cast iron EN-GJL 250
Nuts and bolts	Stainless steel - Class A2-70
Standard gasket	Rubber - NBR
Shaft	Stainless steel - AISI 431
Paint type	Ecological bicomponent epoxy (~ 200 µm)
Cutter	Chromium steel
Strainer	-



## GRG 250/2/G40H

### Performances

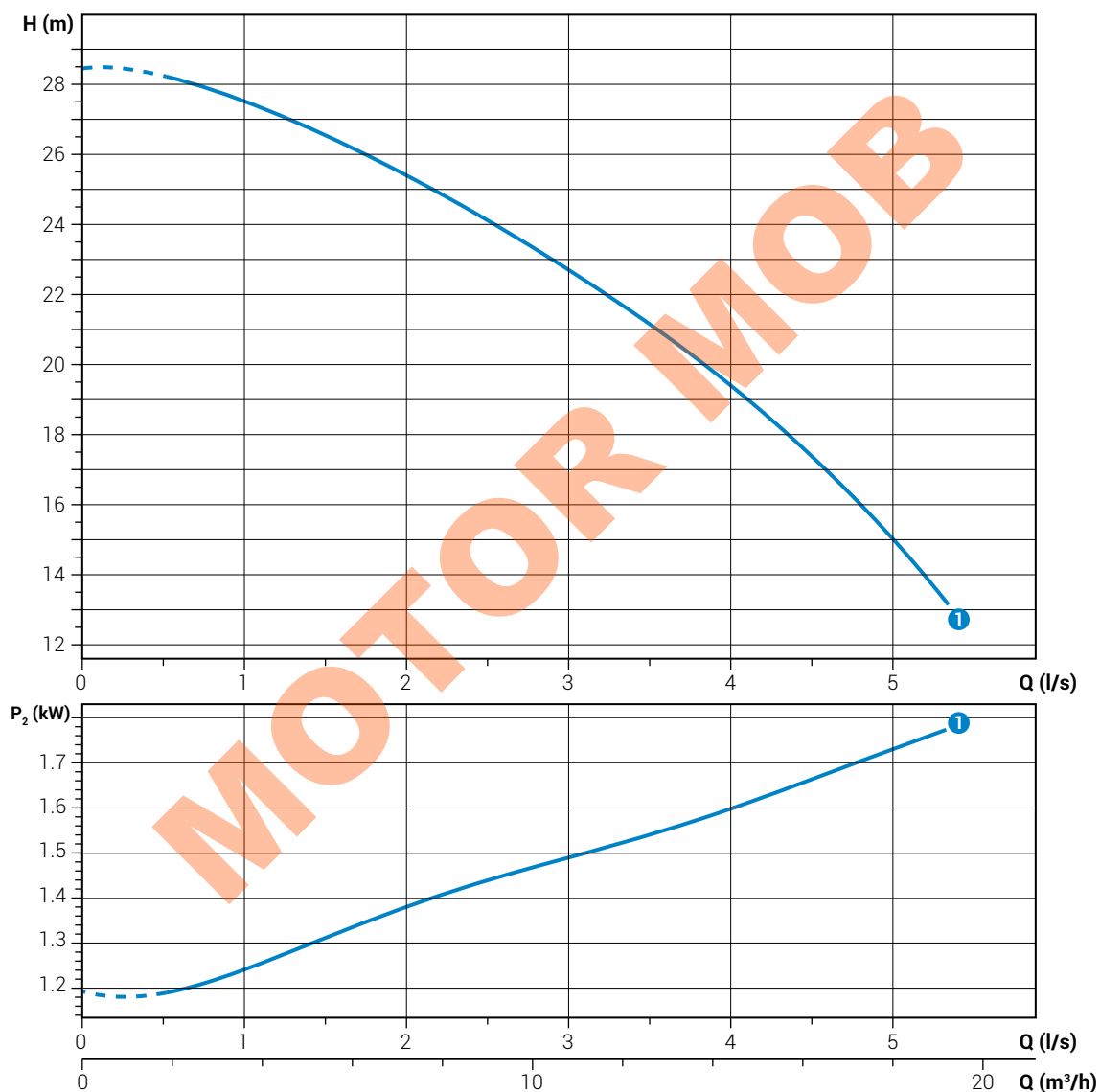
	l/s	0	1	2	3	4	5
	l/min	0	60	120	180	240	300
	m <sup>3</sup> /h	0	3.6	7.2	10.8	14.4	18
① GRG 250/2/G40H A0AT5		28.5	27.5	25.4	22.7	19.4	14.9



### Technical data

	V	1~ 3~	P <sub>1</sub> [kW]	P <sub>2</sub> [kW]	A	Rpm	DOL Y/Δ			
① GRG 250/2/G40H A0AT5	400	3~	2.2	1.8	3.7	2900	DOL	4G1	G1"½ DN32	10 mm



## GRG 300÷1000/2/G50H

### Performances

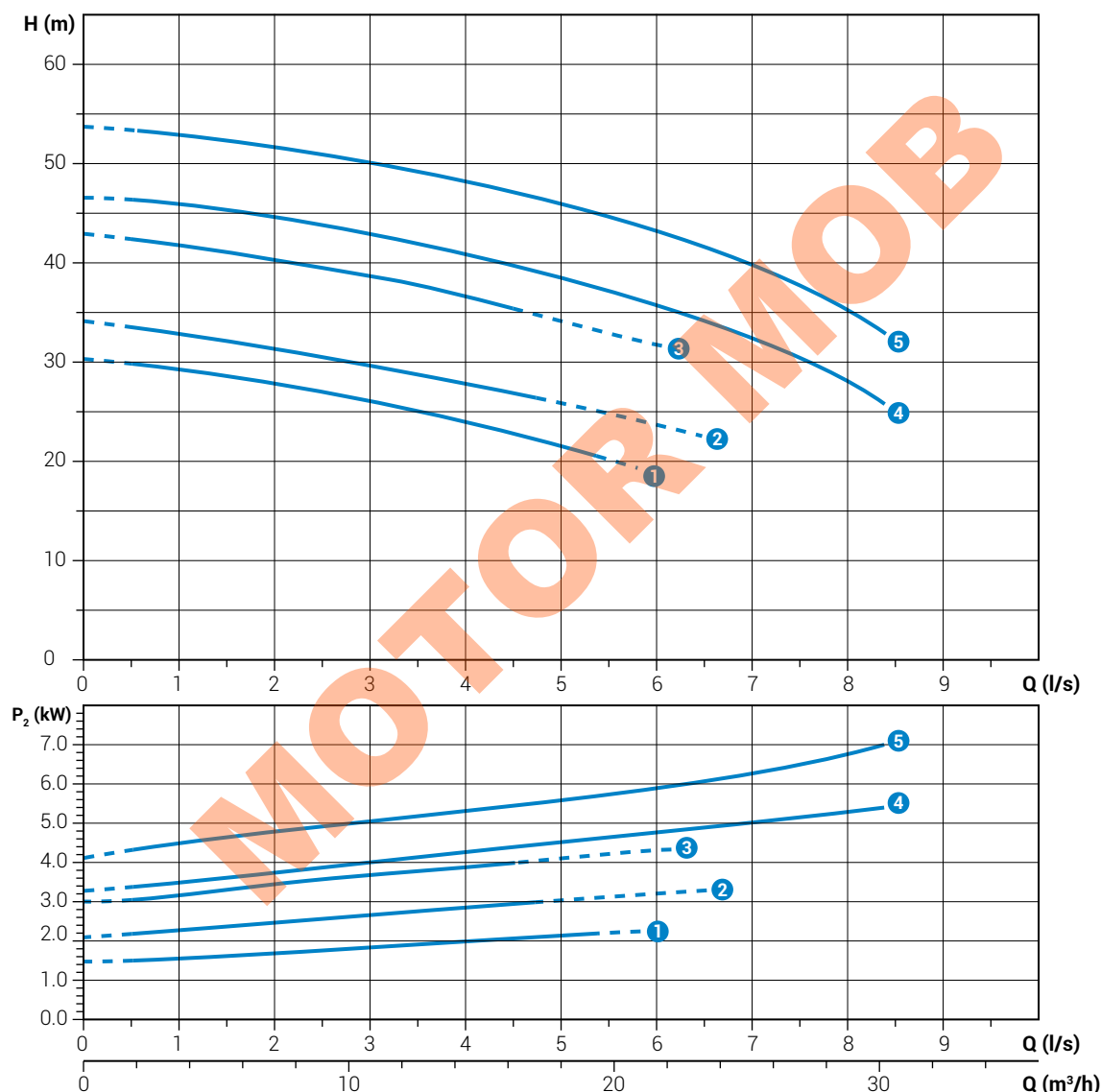
	l/s	0	1	2	3	4	5	6	7	8
	l/min	0	60	120	180	240	300	360	420	480
	m <sup>3</sup> /h	0	3.6	7.2	10.8	14.4	18	21.6	25.2	28.8
①	GRG 300/2/G50H C0ET5	30.3	29.3	27.9	26.1	24.0	21.6			
②	GRG 400/2/G50H D0ET5	34.2	33.0	31.5	29.8	28.0	26.0	23.9		
③	GRG 550/2/G50H D0T5	45.1	44.4	42.8	40.6	38.1	35.3			
④	GRG 750/2/G50H A0FT5	46.6	45.9	44.6	42.8	40.8	38.5	35.8	32.4	27.9
⑤	GRG 1000/2/G50H A0FT5	53.7	52.9	51.6	50.0	48.2	46.0	43.3	39.8	35.2



### Technical data

	V	1~ 3~	P <sub>1</sub> [kW]	P <sub>2</sub> [kW]	A	Rpm	DOL Y/Δ				
①	GRG 300/2/G50H C0ET5	400	3~	2.8	2.2	4.6	2900	DOL	4G1.5+3x1	G2" DN32	-
②	GRG 400/2/G50H D0ET5	400	3~	3.7	3.0	6.4	2900	DOL	4G1.5+3x1	G2" DN32	-
③	GRG 550/2/G50H D0T5	400	3~	4.7	4.0	7.7	2900	DOL	4G1.5+3x1	G2" DN32	-
④	GRG 750/2/G50H A0FT5	400	3~	6.3	5.5	10.8	2900	DOL	4G1.5+3x1	G2" DN32	-
⑤	GRG 1000/2/G50H A0FT5	400	3~	8.5	7.5	13.7	2900	DOL	4G1.5+3x1	G2" DN32	-

## GRG

### Overall dimensions and weights

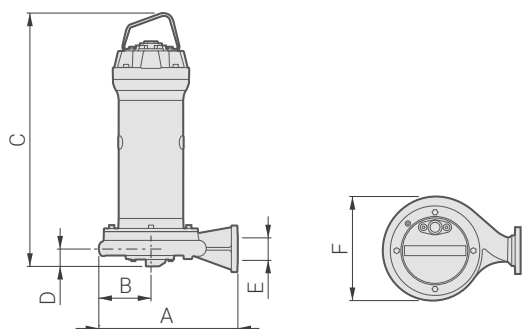

	A	B	C	D	E	F		kg
GRG 250/2/G40H A0AT5	267	103	491	45	G1"½	215	DN32 PN6	32.0
GRG 300/2/G50H C0ET5	305	110	527	56	G2"	225	DN32 PN6	43.2
GRG 400/2/G50H D0ET5	352	132	594	59	G2"	263	DN32 PN6	45.0
GRG 550/2/G50H D0T5	352	128	652	59	G2"	263	DN32 PN6	57.6
GRG 750/2/G50H A0FT5	352	128	652	59	G2"	263	DN32 PN6	60.3
GRG 1000/2/G50H A0FT5	352	128	727	59	G2"	263	DN32 PN6	68.2

Dimensions in mm

### Packaging dimension



	X	Y	Z
GRG 250/2/G40H A0AT5	310	580	310
GRG 300/2/G50H C0ET5	445	725	425
GRG 400/2/G50H D0ET5	445	725	425
GRG 550/2/G50H D0T5	445	725	425
GRG 750/2/G50H A0FT5	445	725	425
GRG 1000/2/G50H A0FT5	535	915	560

Dimensions in mm