

50 Hz



## e-SV™ Series

1, 3, 5, 10, 15, 22

33, 46, 66, 92, 125

VERTICAL MULTISTAGE ELECTRIC PUMPS  
EQUIPPED WITH **IE3** MOTORS

ErP 2009/125/EC

**1SV SERIES, 17 TO 37 STAGES**  
**DIMENSIONS AND WEIGHTS AT 50 Hz, 2 POLES**

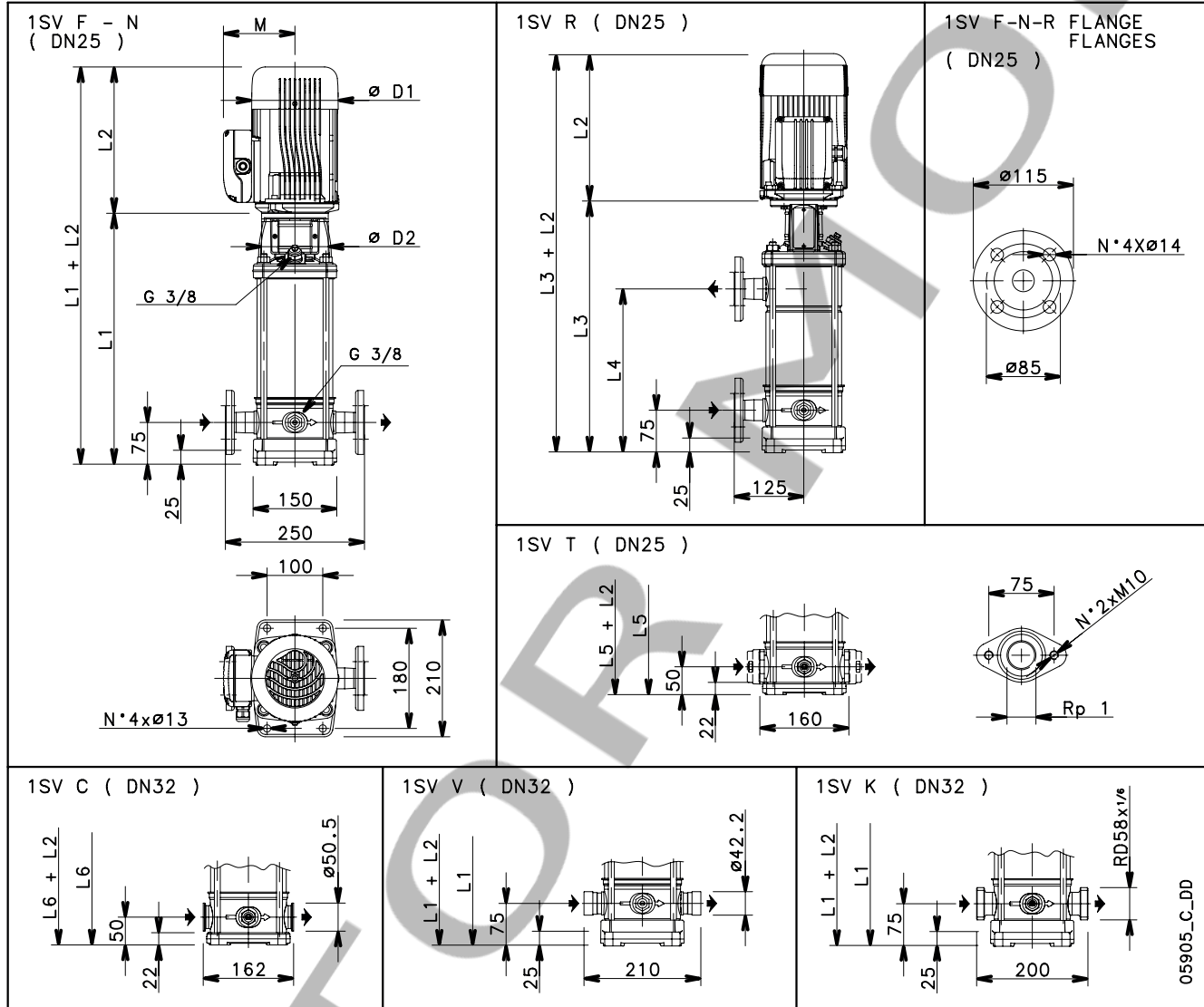

| PUMP TYPE | MOTOR |      | DIMENSIONS (mm) |     |     |     |     |     |     |     |     |     |     |     | WEIGHT kg |          |
|-----------|-------|------|-----------------|-----|-----|-----|-----|-----|-----|-----|-----|-----|-----|-----|-----------|----------|
|           | kW    | SIZE | L1              | L2  |     | L3  | L4  | L5  | L6  | M   |     | D1  |     | D2  | PUMP      | ELECTRIC |
| 1SV17../D | 1,1   | 80   | 568             | 263 | 263 | 568 | 407 | 543 | 543 | 137 | 129 | 155 | 155 | 120 | 14,7      | 26,6     |
| 1SV19../D | 1,1   | 80   | 608             | 263 | 263 | 608 | 447 | 583 | 583 | 137 | 129 | 155 | 155 | 120 | 15,5      | 28       |
| 1SV22../D | 1,1   | 80   | 668             | 263 | 263 | 668 | 507 | 643 | 643 | 137 | 129 | 155 | 155 | 120 | 16,7      | 28,6     |
| 1SV25../D | 1,5   | 90   | 738             | 263 | 263 | 738 | 567 | 713 | 713 | 137 | 129 | 155 | 155 | 140 | 18,7      | 32       |
| 1SV27../D | 1,5   | 90   | 778             | 263 | 263 | 778 | 607 | -   | 753 | 137 | 129 | 155 | 155 | 140 | 19,5      | 33       |
| 1SV30../D | 1,5   | 90   | 838             | 263 | 263 | 838 | 667 | -   | 813 | 137 | 129 | 155 | 155 | 140 | 20,7      | 34       |
| 1SV32../D | 2,2   | 90   | 878             | 298 | 298 | 878 | 707 | -   | 853 | 151 | 134 | 174 | 174 | 140 | 21,5      | 37,8     |
| 1SV34../D | 2,2   | 90   | 918             | 298 | 298 | 918 | 747 | -   | 893 | 151 | 134 | 174 | 174 | 140 | 22,3      | 38,6     |
| 1SV37../D | 2,2   | 90   | 978             | 298 | 298 | 978 | 807 | -   | 953 | 151 | 134 | 174 | 174 | 140 | 23,5      | 39,8     |
|           |       |      |                 |     |     |     |     |     |     |     |     |     |     |     |           |          |
|           |       |      |                 |     |     |     |     |     |     |     |     |     |     |     |           |          |
|           |       |      |                 |     |     |     |     |     |     |     |     |     |     |     |           |          |
|           |       |      |                 |     |     |     |     |     |     |     |     |     |     |     |           |          |

1sv-2-2p50-en\_d\_td

**1SV SERIES, 17 TO 37 STAGES  
OPERATING CHARACTERISTICS AT 50 Hz, 2 POLES**

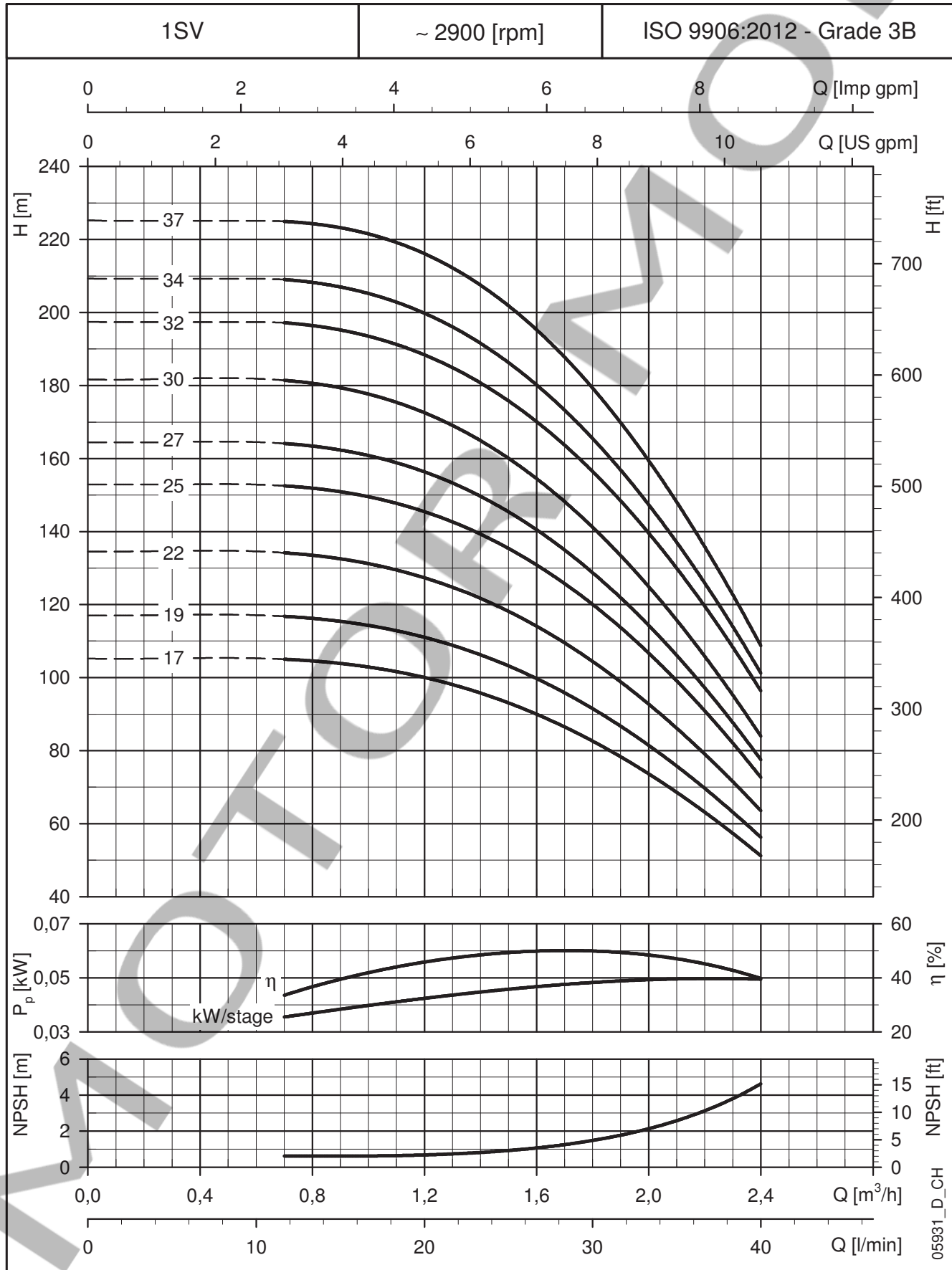

These performances are valid for liquids with density  $\rho = 1.0 \text{ Kg/dm}^3$  and kinematic viscosity  $\nu = 1 \text{ mm}^2/\text{sec}$ .