

50 Hz



e-NSC Series

HORIZONTAL CENTRIFUGAL ELECTRIC PUMPS
EQUIPPED WITH **IE3** MOTORS

ErP 2009/125/EC

Cod. 191002951 Rev. G Ed.07/2017

 **LOWARA**
a xylem brand

e-NSC 32, 40, 50 SERIES HYDRAULIC PERFORMANCE RANGE AT 50 Hz, 4 POLES

PUMP TYPE	P _N kW	Ø Impeller (mm)			η _p % (3)	Q = DELIVERY													
		STD (1)	B (2)	● (2)		l/s 0	0,9	1,3	1,8	2,2	2,7	3,1	3,6	4,0	4,5	4,9	5,4	5,8	
						m ³ /h 0	3	5	6	8	10	11	13	14	16	18	19	21	
H = TOTAL HEAD METRES COLUMN OF WATER																			
32-125/02B	0,25	113	-	○	56,9	3,5	3,5	3,5	3,3	3,1	2,7	2,3							
32-125/02A	0,25	123	-	○	61,1	4,3		4,3	4,2	4,0	3,7	3,3	2,8	2,2					
32-125/02	0,25	133	-	○	63,4	5,3		5,4	5,3	5,1	4,9	4,5	4,1	3,6	2,9				
32-125/03	0,37	145	-	●	64,5	6,7			6,6	6,4	6,2	5,9	5,5	5,1	4,5	3,8	3,1		
32-160/02	0,25	137	-	○	58,5	5,5		5,5	5,4	5,1	4,8	4,3	3,7	3,0					
32-160/03	0,37	150	-	○	62,1	7,0		6,9	6,8	6,6	6,3	5,9	5,3	4,7	3,9				
32-160/05A	0,55	160,5	-	○	63,3	8,4		8,4	8,4	8,2	8,0	7,6	7,1	6,5	5,8	5,0	4,0		
32-160/05	0,55	171	-	●	63,4	9,5			9,5	9,3	9,1	8,8	8,3	7,8	7,1	6,2	5,3	4,2	
32-200/05A	0,55	158	-	○	54,3	7,9		7,9	7,7	7,4	6,7	5,9	4,9						
32-200/05	0,55	171	-	○	56,5	9,5		9,4	9,3	9,0	8,5	7,7	6,8	5,7					
32-200/07	0,75	186	-	○	58,5	11,9		11,9	11,8	11,6	11,3	10,8	10,0	9,1	7,9				
32-200/11	1,1	205	-	●	60,6	15,1			15,0	14,9	14,7	14,4	13,9	13,2	12,2	11,0			
NSC2 32-250/11A	1,10	177	-	○	47,3	18,7		17,0	16,1	14,8	13,3	11,5	9,6						
NSC2 32-250/11	1,1	195	-	●	50,0	23,3		21,6	20,8	19,7	18,2	16,4	14,3	12,0					
32-250/11A	1,1	214	-	○	44,4	14,5			14,1	13,7	13,1	12,2	11,1						
32-250/15B	1,5	214	-	○	44,4	14,5			14,1	13,7	13,1	12,2	11,1						
32-250/11	1,1	226,5	-	○	45,7	16,3			15,9	15,5	15,0	14,2	13,2	11,9					
32-250/15A	1,5	226,5	-	○	45,7	16,3			15,9	15,5	15,0	14,2	13,2	11,9					
32-250/15	1,5	239	-	○	46,1	18,7				17,8	17,3	16,6	15,7	14,5	13,0				
32-250/22	2,2	259	-	●	46,7	22,6				21,9	21,5	20,9	20,2	19,3	18,1	16,6	14,6		

PUMP TYPE	P _N kW	Ø Impeller (mm)			η _p % (3)	Q = DELIVERY													
		STD (1)	B (2)	● (2)		l/s 0	1,3	2,1	2,8	3,6	4,3	5,0	5,8	6,5	7,2	8,0	8,7	9,4	
						m ³ /h 0	5	7	10	13	15	18	21	23	26	29	31	34	
H = TOTAL HEAD METRES COLUMN OF WATER																			
40-125/02A	0,25	105	-	○	66,1	3,6	3,6	3,5	3,4	3,1	2,8	2,4							
40-125/02	0,25	118	-	○	70,5	4,6		4,4	4,3	4,1	3,8	3,4	2,9						
40-125/03	0,37	130	-	○	73,3	5,6		5,5	5,4	5,3	5,0	4,7	4,3	3,8	3,2				
40-125/05	0,55	135	-	●	74,0	6,5			6,3	6,1	5,9	5,6	5,2	4,8	4,3	3,7			
40-160/03	0,37	127	-	○	66,6	5,2		5,3	5,2	5,0	4,6	4,1	3,6						
40-160/05	0,55	139	-	○	69,0	6,6		6,6	6,6	6,4	6,2	5,8	5,3	4,7					
40-160/07	0,75	154	-	○	70,8	8,3		8,4	8,4	8,4	8,2	7,9	7,6	7,1	6,4	5,7			
40-160/11	1,1	165	-	●	71,1	10,1			10,1	10,0	9,9	9,6	9,3	8,9	8,4	7,8	7,0		
40-200/07	0,75	165	-	○	59,5	9,0		8,9	8,8	8,6	8,2	7,5	6,5	5,2					
40-200/11	1,1	179	-	○	60,6	10,9		11,0	11,0	10,9	10,6	10,1	9,3	8,2	6,9				
40-200/15A	1,5	189	-	○	60,9	12,4			12,5	12,4	12,2	11,7	11,1	10,2	9,0	7,4			
40-200/15	1,5	199	-	●	62,8	14,0			14,0	13,9	13,6	13,3	12,8	12,0	11,1	9,8	8,3	6,4	
40-250/11	1,1	199	-	○	57,9	13,5			13,3	12,9	12,4	11,6	10,6						
40-250/15A	1,5	199	-	○	57,9	13,5			13,3	12,9	12,4	11,6	10,6						
40-250/15	1,5	210	-	○	58,8	15,1			14,9	14,7	14,3	13,6	12,7	11,6					
40-250/22A	1,5	228	-	○	59,1	18,0			18,0	17,8	17,5	17,1	16,4	15,5	14,3				
40-250/22	2,2	243	-	○	60,4	20,6				20,5	20,3	19,9	19,4	18,6	17,6	16,4			
40-250/30	3	257,5	-	●	63,9	24,4				24,1	23,9	23,6	23,1	22,5	21,6	20,6	19,2		

PUMP TYPE	P _N kW	Ø Impeller (mm)			η _p % (3)	Q = DELIVERY													
		STD (1)	B (2)	● (2)		l/s 0	2,3	3,9	5,5	7,2	8,8	10,4	12,0	13,6	15,2	16,8	18,4	20,0	
						m ³ /h 0	8	14	20	26	32	37	43	49	55	60	66	72	
H = TOTAL HEAD METRES COLUMN OF WATER																			
50-125/03	0,37	118	-	○	67,5	4,1		3,7	3,4	3,0	2,4	1,7							
50-125/05	0,55	130	-	○	69,8	5,2		4,8	4,5	4,1	3,5	2,8	2,0						
50-125/07	0,75	144	-	○	71,0	6,7		6,3	6,0	5,7	5,2	4,6	3,9	3,0					
50-125/11	1,1	148	-	●	74,6	7,6		7,2	7,0	6,7	6,3	5,8	5,2	4,4	3,6				
50-160/07	0,75	144	-	○	69,9	6,8		6,4	6,1	5,6	4,9	4,1							
50-160/11A	1,1	159	-	○	70,4	8,4		8,1	7,8	7,3	6,7	5,9	4,9						
50-160/11	1,1	170	-	○	71,8	9,6		9,3	9,0	8,6	8,0	7,3	6,4	5,4					
50-160/15	1,5	176	-	●	72,3	10,8		10,3	10,0	9,7	9,2	8,5	7,7	6,7	5,5				
50-200/11	1,1	168	-	○	68,9	8,9		9,1	9,0	8,7	8,0	6,9							
50-200/15A	1,5	168	-	○	68,9	8,9		9,1	9,0	8,7	8,0	6,9							
50-200/15	1,5	179	-	○	70,5	10,4		10,6	10,6	10,3	9,7	8,7	7,4						
50-200/22A	2,2	197	-	○	72,0	13,1		13,3	13,3	13,1	12,6	11,8	10,7	9,2					
50-200/22	2,2	209	-	●	73,3	15,1		15,1	15,1	14,8	14,4	13,7	12,7	11,4					
50-250/22A	2,2	208	-	○	67,2	14,7		14,6	14,3	13,6	12,6	11,1	9,0						
50-250/22	2,2	220	-	○	68,3	16,6		16,5	16,2	15,7	14,7	13,3	11,4						
50-250/30	3	232	-	○	68,5	18,7		18,6	18,3	17,8	16,9	15,7	13,9	11,6					
50-250/40	4	256	-	●	68,6	22,8			22,6	22,2	21,6	20,5	19,0	17,1	14,6				
50-315/40	4	265	-	○	60,0	22,6	22,5	22,2	21,7	21,0	20,2	19,2	17,9	16,1					
50-315/55	5,5	278	-	○	61,1	27,4		27,0	26,6	25,9	25,1	24,1	23,0	21,7	19,8	17,0			
50-315/75	7,5	304	-	○	63,2	33,3		33,1	32,8	32,2	31,4	30,4	29,4	28,3	27,0	25,2	22,5		
50-315/110	11	322	-	●	63,3	37,6		37,3	37,0	36,5	35,9	35,1	34,1	32,9	31,5	29,7	27,5	24,8	

Hydraulic performances in compliance with ISO 9906:2012 - Grade 3B (ex ISO 9906:1999 - Annex A)

Nsc-32-40-50_4p50-en_d_th

(1) STD = Cast iron/Stainless steel - B = Bronze (2) ● = Full impeller diameter - ○ = Trimmed impeller diameter (3) Hydraulic efficiency of pump.

e-NSC 65, 80 SERIES

HYDRAULIC PERFORMANCE RANGE AT 50 Hz, 4 POLES

PUMP TYPE	P _N kW	Ø Impeller (mm)				Q = DELIVERY												
		STD (1)	B (2)	O (3)	η _p %	l/s	3,3	6,3	9,3	12,2	15,2	18,2	21,2	24,2	27,2	30,1	33,1	36,1
						m ³ /h	0	12	23	33	44	55	66	76	87	98	109	119
H = TOTAL HEAD METRES COLUMN OF WATER																		
65-125/05	0,55	113	112	○	75,0	3,5		3,4	3,1	2,7	2,1							
65-125/07	0,75	127	126	○	77,0	4,9		4,7	4,4	3,9	3,2	2,4						
65-125/11	1,1	137	136	○	78,3	5,8		5,8	5,6	5,1	4,5	3,6	2,7					
65-125/15	1,5	148	146	●	79,5	7,2		7,1	6,9	6,5	6,0	5,4	4,6	3,6				
65-160/11A	1,1	145	144	○	77,1	6,4		6,4	6,0	5,4	4,4	3,4						
65-160/15B	1,5	145	144	○	77,1	6,4		6,4	6,0	5,4	4,4	3,4						
65-160/11	1,1	151	152	○	78,0	7,2		7,0	6,7	6,1	5,2	4,1						
65-160/15A	1,5	151	152	○	78,0	7,2		7,0	6,7	6,1	5,2	4,1						
65-160/15	1,5	159	160	○	79,6	8,2		8,0	7,7	7,1	6,3	5,3						
65-160/22A	2,2	175	176	○	81,8	10,2		10,1	9,9	9,4	8,8	7,9	6,8	5,6				
65-160/22	2,2	180	180	●	82,1	10,9		10,8	10,5	10,0	9,3	8,4	7,4	6,1				
65-200/15	1,5	165	162	○	73,1	8,9	8,9	8,7	8,2	7,2	5,7							
65-200/22A	2,2	177	177	○	74,6	10,6		10,5	10,0	9,2	7,8	6,0						
65-200/22	2,2	189	189	○	76,9	12,1		12,0	11,6	10,8	9,6	7,9	5,7					
65-200/30	3	199	199	○	78,0	13,6		13,6	13,2	12,6	11,5	9,9	7,8					
65-200/40	4	220	218	●	80,0	17,0		16,9	16,7	16,1	15,3	14,1	12,5	10,3				
65-250/30	3	195	192	○	73,9	12,6		13,2	12,8	12,0	10,8	9,3	7,3					
65-250/40	4	215	213	○	74,3	15,7		16,2	15,8	15,1	14,1	12,7	11,0	8,9				
65-250/55A	5,5	229	226	○	76,0	18,1		19,0	18,7	18,1	17,3	16,1	14,6	12,8	10,5			
65-250/55	5,5	243	240	○	77,2	20,7		21,3	21,2	20,7	20,0	18,9	17,5	15,8	13,7			
65-250/75	7,5	258	255	●	77,6	24,3		24,6	24,3	23,8	23,0	22,0	20,8	19,2	17,4	15,2		
65-315/55	5,5	260	260	○	68,1	22,7		22,4	21,7	20,8	19,6	18,0	15,7	12,7				
65-315/75	7,5	285	285	○	70,4	27,6		27,3	26,8	26,0	24,8	23,3	21,4	18,9	15,9			
65-315/110	11	315	315	○	71,4	34,7		34,5	34,0	33,3	32,3	31,0	29,3	27,2	24,6	21,4	17,3	
65-315/150	15	334	334	●	72,2	39,0		38,9	38,5	37,8	36,8	35,5	33,9	32,0	29,7	27,0	23,8	20,3

PUMP TYPE	P _N kW	Ø Impeller (mm)				Q = DELIVERY												
		STD (1)	B (2)	O (3)	η _p %	l/s	5,6	10,7	15,7	20,8	25,8	30,9	35,9	40,9	46,0	51,0	56,1	61,1
						m ³ /h	0	20	38	57	75	93	111	129	147	166	184	202
H = TOTAL HEAD METRES COLUMN OF WATER																		
80-160/15	1,5	144	144	○	72,1	6,5		6,2	5,5	4,5	3,5							
80-160/22A	2,2	158	158	○	78,4	8,3		7,9	7,3	6,5	5,4	4,2						
80-160/22	2,2	168	168	○	79,0	9,3		9,0	8,5	7,6	6,5	5,2	3,8					
80-160/30	3	177	177	●	81,2	10,5		10,2	9,8	9,0	8,0	6,7	5,3					
80-200/30	3	181	177	○	77,1	10,8		10,6	10,1	9,3	8,2							
80-200/40	4	195	192	○	79,7	12,8		12,7	12,4	11,6	10,4	8,9						
80-200/55A	5,5	208	204	○	82,0	15,0		14,9	14,5	13,9	12,8	11,3						
80-200/55	5,5	219	216	●	82,5	16,9		16,5	16,2	15,6	14,7	13,5	11,8					
80-250/55A	5,5	214	211	○	80,0	16,4		16,0	15,4	14,4	13,1	11,3	9,1	6,5				
80-250/55	5,5	227	224	○	80,1	18,2		18,2	17,6	16,6	15,3	13,5						
80-250/75	7,5	241	238	○	80,8	21,0		20,7	20,2	19,4	18,1	16,4	14,4					
80-250/110	11	259	256	●	82,2	24,1		23,9	23,7	23,2	22,2	20,8	19,0	16,7				
80-315/110A	11	262	262	○	75,8	23,1		23,1	22,7	21,9	20,4	18,4	15,8	12,8	9,6			
80-315/110	11	280	280	○	76,0	26,6		26,6	26,4	25,7	24,5	22,8	20,4	17,5				
80-315/150	15	304	304	○	76,9	31,6		31,7	31,6	31,2	30,3	28,9	26,8	24,3	21,2			
80-315/185	18,5	321	321	○	77,2	35,5		35,6	35,5	35,2	34,4	33,2	31,4	29,1	26,2	22,7		
80-315/220	22	334	334	●	77,8	38,6		38,7	38,6	38,3	37,6	36,4	34,8	32,7	30,0	26,7		
80-400/185	18,5	338	338	○	69,9	39,1		39,0	38,2	37,0	35,3	33,3	30,6	27,0	22,0	15,0	5,1	
80-400/220	22	356	356	○	71,3	43,8	44,0	43,8	43,2	42,0	40,4	38,4	36,1	33,1	29,1			
80-400/300	30	388	388	○	72,5	53,1		52,8	52,6	51,7	50,2	48,3	46,1	43,7	40,8			
80-400/370	37	418	418	●	73,8	62,6		61,9	61,7	61,0	59,7	57,9	55,9	53,5	50,9	47,8		

Hydraulic performances in compliance with ISO 9906:2012 - Grade 3B (ex ISO 9906:1999 - Annex A)

Nsc-65-80_4p50-en_d_th

(1) STD = Cast iron/Stainless steel - B = Bronze (2) ● = Full impeller diameter - ○ = Trimmed impeller diameter (3) Hydraulic efficiency of pump.

e-NSC 100-125-150 SERIES HYDRAULIC PERFORMANCE RANGE AT 50 Hz, 4 POLES

PUMP TYPE	P _N kW	Ø Impeller (mm)				Q = DELIVERY													
		STD	B	●	η _p %	l/s	0	5.6	12.6	19.7	26.8	33.8	40.9	48.0	55.1	62.1	69.2	76.3	83.3
						m ³ /h	0	20	45	71	96	122	147	173	198	224	249	275	300
H = TOTAL HEAD METRES COLUMN OF WATER																			
100-160/22A	2.2	144	144	○	75.9	5.9		5.9	5.6	4.9	3.7								
100-160/22	2.2	156	156	○	77.4	6.9		6.9	6.6	6.0	4.8	3.5							
100-160/30	3	176	176	○	81.5	9.1		9.0	8.8	8.1	7.0	5.6	4.0						
100-160/40	4	190	190	●	83.6	10.8		10.6	10.4	9.8	8.9	7.6	6.0						
100-200/40	4.0	197	197	○	82.6	12.2		12.1	11.8	11.0	9.6	7.5	5.1						
100-200/55	5.5	213	213	○	83.8	14.8		14.6	14.5	13.8	12.6	10.7	8.4						
100-200/75	7.5	227	227	●	84.3	16.9		16.7	16.5	15.9	14.8	13.1	11.0	8.4					
100-250/55	5.5	213	213	○	80.6	14.1		14.1	13.8	13.1	11.9	10.1	8.0						
100-250/75	7.5	237	237	○	83.1	17.8		17.9	17.7	17.2	16.2	14.6	12.5	10.1					
100-250/110	11	259	259	●	84.1	21.9		21.9	21.7	21.1	20.0	18.4	16.3	13.8					
100-315/110	11	260	260	○	78.9	23.5	23.5	23.4	23.1	22.4	21.1	19.2	16.5	12.6					
100-315/150	15	284	284	○	79.5	28.0		28.0	27.8	27.2	26.0	24.4	22.4	19.5					
100-315/185	18.5	298	298	○	79.9	31.1		31.0	30.9	30.3	29.3	27.8	26.1	23.8	20.4				
100-315/220	22	312	312	○	80.6	34.3		34.2	34.1	33.7	32.8	31.4	29.6	27.6	25.0				
100-315/300	30	334	334	●	80.8	40.2		40.1	40.1	39.7	38.8	37.6	36.0	34.0	31.5	28.2			
100-400/300	30	375	375	○	76.8	47.4		46.5	45.8	44.9	43.7	42.1	40.0	37.4	34.3	30.6			
100-400/370	37	397	397	○	77.1	54.4		53.3	52.5	51.6	50.4	48.9	47.1	44.8	42.0	38.6	34.7		
100-400/450	45	420	420	●	76.9	61.3		60.0	59.4	58.6	57.3	55.7	53.8	51.6	49.0	45.8	42.0	37.3	

PUMP TYPE	P _N kW	Ø Impeller (mm)				Q = DELIVERY													
		STD	B	●	η _p %	l/s	0	11.9	21.4	30.9	40.5	50.0	59.5	69.0	78.6	88.1	97.6	107.1	116.7
						m ³ /h	0	43	77	111	146	180	214	249	283	317	351	386	420
H = TOTAL HEAD METRES COLUMN OF WATER																			
125-200/55	5.5	179	179	○	80.9	8.6		8.4	8.4	8.3	8.0	7.2	6.0						
125-200/75	7.5	204	204	○	83.5	11.9		11.8	11.8	11.6	11.2	10.3	9.0	7.5					
125-200/110	11	225	225	●	85.4	15.0		14.9	14.9	14.8	14.4	13.7	12.6	11.1	9.3				
125-250/75	7.5	210	210	○	84.5	13.6	13.5	13.4	13.3	12.9	12.1	10.6	8.6	6.3					
125-250/110	11	235	235	○	86.3	17.5		17.4	17.4	17.2	16.6	15.3	13.5	11.3	9.2				
125-250/150	15	259	259	●	88.3	22.0		21.7	21.7	21.5	21.0	20.0	18.5	16.5	14.1	11.6			
125-315/185	18.5	277	277	○	83.7	25.6		25.7	25.6	25.3	24.4	22.8	20.1	16.4	11.9	7.3			
125-315/220	22	290	290	○	84.3	28.3		28.6	28.5	28.2	27.5	26.1	23.8	20.7	16.6				
125-315/300	30	315	315	○	85.4	34.8		35.1	35.0	34.8	34.1	33.0	31.4	29.1	26.0	22.1			
125-315/370	37	334	334	●	86.4	39.6		39.8	39.9	39.7	39.2	38.2	36.8	34.8	32.1	28.7	24.6		
125-400/370	37	353	353	○	78.0	43.4		43.9	43.8	43.2	41.9	39.9	37.0	33.0	28.0				
125-400/450	45	374	374	○	78.8	48.7		49.4	49.6	49.3	48.3	46.4	43.7	40.0	35.4	30.0			
125-400/550	55	394	394	○	79.1	54.4		55.6	55.8	55.5	54.6	53.0	50.7	47.6	43.6	38.7			
125-400/750	75	422	422	●	79.9	63.4		64.8	64.7	64.2	63.3	61.8	59.8	57.1	53.8	49.8	45.0	39.3	

PUMP TYPE	P _N kW	Ø Impeller (mm)				Q = DELIVERY													
		STD	B	●	η _p %	l/s	0	16.7	33.8	51.0	68.2	85.4	102.5	119.7	136.9	154.0	171.2	188.4	205.6
						m ³ /h	0	60	122	184	245	307	369	431	493	555	616	678	740
H = TOTAL HEAD METRES COLUMN OF WATER																			
150-200/110A	11	200	200	○	78.8	11.8		11.3	10.5	9.4	8.3	7.0	5.4						
150-200/110	11	217	217	○	80.7	14.0		13.4	12.5	11.4	10.1	8.7	7.0	4.9					
150-200/150A	15	227	227	○	82.0	15.2		14.5	13.8	12.9	11.7	10.2	8.4	6.4					
150-200/150	15	237	237	●	83.9	16.3		15.6	15.1	14.4	13.4	12.0	10.3	8.2					
150-250/150	15	238	238	○	80.3	17.2	17.0	16.7	16.1	15.1	13.7	11.6	9.1						
150-250/185	18.5	253	253	○	82.7	19.8		19.1	18.7	17.9	16.6	14.8	12.4	9.5					
150-250/220	22	265	265	○	84.6	22.1		21.4	21.0	20.4	19.3	17.6	15.4	12.6					
150-250/300	30	282	282	●	86.2	26.4		25.3	24.7	23.9	22.9	21.5	19.6	17.3	14.4				
150-315/300	30	291	291	○	84.2	27.7		27.7	27.6	27.0	25.7	23.5	20.4	16.5					
150-315/370	37	310	310	○	85.1	31.9		31.8	31.6	31.1	30.0	28.1	25.3	21.5	17.1				
150-315/450	45	330	330	●	86.3	36.6		36.2	36.1	35.7	34.7	32.9	30.4	27.2	23.2				
150-400/450	45	327	327	○	81.8	36.7		36.9	36.6	35.6	34.0	31.7	28.6	24.6					
150-400/550	55	346	346	○	84.4	41.2		41.6	41.5	40.9	39.5	37.5	34.6	30.9	26.3				
150-400/750	75	377	377	○	84.9	50.3		50.8	50.9	50.4	49.1	47.0	44.4	41.3	37.7	33.3			
150-400/900	90	398	398	○	85.3	56.5		56.9	57.0	56.5	55.5	53.7	51.4	48.5	45.1	41.0			
150-400/1100	110	423	423	●	85.5	63.9		64.4	64.3	63.9	63.0	61.5	59.4	56.6	53.2	49.1	44.4		
150-500/900	90	420	420	○	75.1	60.9		61.6	61.8	61.1	59.0	55.2	49.6	42.6	34.5				
150-500/1100	110	443	443	○	75.4	68.5		68.9	69.3	69.0	67.5	64.4	59.5	52.7	44.6	36.1			
150-500/1320	132	467	467	○	76.5	76.9		77.6	78.1	78.0	76.9	74.3	70.1	64.0	56.3	47.3			
150-500/1600	160	495	495	○	77.9	87.0		87.9	88.4	88.5	87.8	86.0	82.7	77.6	70.7	62.1	52.6		
150-500/2000	200	516	516	●	78.6	95.1		95.9	96.5	96.7	96.1	94.4	91.4	86.7	80.4	72.6	63.5	53.7	

Hydraulic performances in compliance with ISO 9906:2012 - Grade 3B (ex ISO 9906:1999 - Annex A)

Nsc-100-150_4p50-en_c_th

(1) STD = Cast iron/Stainless steel - B = Bronze (2) ● = Full impeller diameter - ○ = Trimmed impeller diameter (3) Hydraulic efficiency of pump.

e-NSC 200-250-300 SERIES HYDRAULIC PERFORMANCE RANGE AT 50 Hz, 4 POLES

PUMP TYPE	P _N kW	Ø Impeller (mm)				Q = DELIVERY												
		STD (1)	B (2)	● (3)	η _p %	Vs 0 m ³ /h 0	38,1 137	62,4 225	86,7 312	111,0 400	135,3 487	159,6 575	184,0 662	208,3 750	232,6 837	256,9 925	281,2 1012	305,6 1100
H = TOTAL HEAD METRES COLUMN OF WATER																		
200-250/185	18,5	228	228	○	78,6	15,7	15,3	14,8	13,7	12,2	10,6	8,9	6,8					
200-250/220	22	245	245	○	81,6	18,5		17,2	16,2	14,8	13,1	11,1	8,7					
200-250/300A	30	260	260	○	83,9	21,2		19,7	18,7	17,4	15,8	13,7	11,2	8,4				
200-250/300	30	271	271	●	85,0	23,1		21,5	20,5	19,4	17,9	16,0	13,6	10,8				
200-315/300	30	268	268	○	80,7	22,1	21,7	21,3	20,7	19,6	17,7	14,9	11,3					
200-315/450	37	287	287	○	82,9	25,3		24,6	24,2	23,3	21,7	19,3	15,9	11,8				
200-315/370	45	306	306	○	84,8	29,0		28,3	28,1	27,4	26,1	23,9	20,8	16,8	12,3			
200-315/550	55	328	328	○	86,1	34,1		33,2	32,8	32,1	30,9	28,8	26,0	22,2	17,8			
200-315/750	75	333	333	●	86,3	35,1		34,3	34,0	33,3	32,0	29,9	27,1	23,4	19,1			
200-400/750A	75	328	328	○	83,4	37,2		37,0	36,7	35,7	33,8	31,0	27,0	22,0				
200-400/750	75	342	342	○	83,5	41,0		40,6	40,3	39,4	37,7	35,0	31,3	26,5				
200-400/900	90	362	362	○	84,2	46,5		46,0	45,7	44,9	43,4	41,1	37,7	33,3	27,9			
200-400/1100	110	383	383	○	85,4	52,4		52,2	51,9	51,2	50,0	48,0	45,1	41,2	36,2			
200-400/1320	132	409	409	●	85,5	60,1		59,8	59,6	59,0	57,9	56,1	53,5	50,0	45,4	39,6		
200-500/1320	132	425	425	○	80,5	64,3		64,4	63,7	62,5	60,2	56,4	50,8	43,3	34,2			
200-500/1600	160	450	450	○	81,2	72,8		72,7	72,2	71,0	69,0	65,8	61,2	55,0	46,9			
200-500/2000	200	480	480	○	82,6	83,8		83,6	83,1	82,1	80,3	77,7	74,0	69,1	62,5	53,8		
200-500/2500	250	508	508	○	83,0	94,3		93,8	93,3	92,3	90,7	88,3	85,1	81,0	75,8	69,2	60,7	
200-500/3150	315	523	523	●	83,3	100,3		99,6	99,1	98,1	96,4	94,1	91,0	87,2	82,5	76,6	69,1	59,6

PUMP TYPE	P _N kW	Ø Impeller (mm)				Q = DELIVERY												
		STD (1)	B (2)	● (3)	η _p %	Vs 0 m ³ /h 0	61,9 223	94,2 339	126,4 455	158,7 571	190,9 687	223,2 803	255,4 920	287,7 1036	319,9 1152	352,2 1268	384,4 1384	416,7 1500
H = TOTAL HEAD METRES COLUMN OF WATER																		
250-315/370	37	255	255	○	81,1	19,4	19,2	18,5	17,7	16,7	15,3	13,3	10,4					
250-315/450	45	273	273	○	83,1	22,7		21,8	21,0	20,1	18,9	16,9	13,8	10,0				
250-315/550	55	290	290	○	84,5	26,1		24,8	24,3	23,6	22,6	20,7	18,0	14,5				
250-315/750	75	316	316	●	85,7	31,5		29,9	29,5	29,1	28,4	27,1	25,0	22,1	18,6			
250-400/750	75	325	325	○	82,0	35,4		35,2	34,3	32,5	29,9	26,3	21,8	16,4				
250-400/900	90	344	344	○	82,9	39,8		39,8	39,2	37,9	35,6	32,3	27,9	22,5				
250-400/1100	110	365	365	○	84,0	45,1		45,0	44,8	43,8	42,0	39,1	35,1	30,0	23,9			
250-400/1320	132	386	386	○	85,1	50,8		50,6	50,4	49,7	48,1	45,6	42,0	37,3	31,5			
250-400/1600	160	407	407	○	85,8	56,9		56,4	56,2	55,6	54,2	52,0	48,9	44,7	39,4	33,0		
250-400/2000	200	425	425	●	86,5	62,7		62,0	61,6	60,9	59,6	57,6	54,9	51,2	46,5	40,6		
250-500/1600	160	420	420	○	82,3	61,1		61,6	60,8	59,2	56,4	52,2	46,3	38,1				
250-500/2000	200	448	448	○	84,5	70,3		71,0	70,7	69,6	67,6	64,1	59,0	51,8	42,3			
250-500/2500	250	477	477	○	84,6	80,5		81,0	80,6	79,7	78,2	75,6	71,8	66,3	58,8	48,9		
250-500/3150	315	508	508	○	84,9	92,6		93,3	92,7	91,6	90,0	87,6	84,5	80,3	74,8	67,8	58,9	
250-500/3550	355	523	523	●	85,0	98,3		99,0	98,4	97,3	95,7	93,6	90,6	86,8	81,9	75,7	68,0	58,5

PUMP TYPE	P _N kW	Ø Impeller (mm)				Q = DELIVERY												
		STD (1)	B (2)	● (3)	η _p %	Vs 0 m ³ /h 0	92,8 334	132,3 476	171,9 619	211,4 761	251,0 903	290,5 1046	330,1 1188	369,6 1331	409,1 1473	448,7 1615	488,2 1758	527,8 1900
H = TOTAL HEAD METRES COLUMN OF WATER																		
300-350/750A	75	285	285	○	79,0	24,4		22,4	21,4	20,0	18,3	16,3	13,9	11,3	8,2			
300-350/750	75	315	315	○	82,2	30,5		28,1	26,8	25,3	23,4	21,2	18,7	15,9	12,7	9,1		
300-350/900	90	332	332	○	83,2	34,7		32,0	30,7	29,1	27,3	25,2	22,7	19,9	16,8	13,3		
300-350/1100	110	354	354	●	85,8	39,7		37,1	36,0	34,6	32,9	30,9	28,5	25,8	22,7	19,2	15,4	
300-400/1100	110	346	346	○	88,2	36,2		36,3	35,9	34,9	33,2	30,8	27,6	23,7	19,1			
300-400/1320	132	367	367	○	87,5	41,9		41,4	41,0	40,2	38,8	36,6	33,6	29,7	25,0	19,7		
300-400/1600	160	390	390	○	86,0	48,0		47,2	46,9	46,3	45,3	43,6	41,0	37,4	32,8	27,4	21,5	
300-400/2000	200	416	416	○	84,2	56,2		55,0	54,7	54,2	53,2	51,7	49,5	46,5	42,6	37,8	32,1	
300-400/2500	250	425	425	●	82,9	59,3		57,9	57,5	56,9	56,0	54,5	52,5	49,7	46,1	41,6	36,0	29,4
300-450/1600	160	404	404	○	86,6	52,5	53,1	52,5	51,4	49,8	47,6	44,8	41,5	37,5	32,9			
300-450/2000	200	430	430	○	88,0	60,7		60,2	59,4	58,1	56,3	53,8	50,7	46,9	42,3	36,9		
300-450/2500	250	456	456	○	88,1	69,1		69,0	68,0	66,7	65,0	62,9	60,3	57,0	53,1	48,1		
300-450/3150	315	470	470	●	89,0	74,9		73,5	72,8	71,6	70,0	67,9	65,4	62,4	58,8	54,5	49,3	

Hydraulic performances in compliance with ISO 9906:2012 - Grade 3B (ex ISO 9906:1999 - Annex A)

Nsc-200-300_4p50-en_c_th

(1) STD = Cast iron/Stainless steel - B = Bronze (2) ● = Full impeller diameter - ○ = Trimmed impeller diameter (3) Hydraulic efficiency of pump.

e-NSC SERIES

OPERATING CHARACTERISTICS AT 50 Hz, 4 POLES

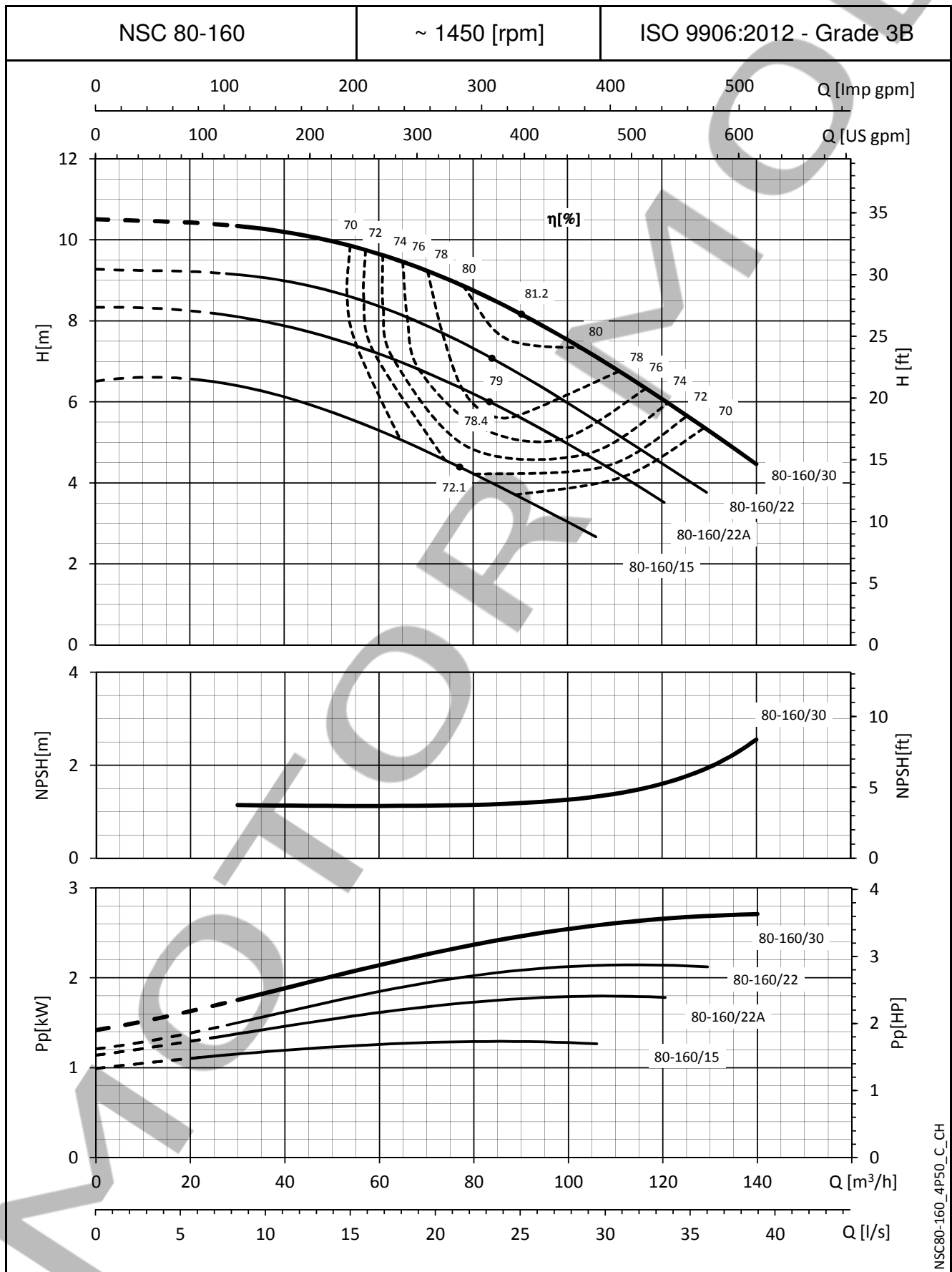

NSC80-160_4P50_C_CH

The NPSH values are laboratory values; for practical use we suggest increasing these values by 0,5 m.
 These performances are valid for liquids with density $\rho = 1,0 \text{ Kg/dm}^3$ and kinematic viscosity $\nu = 1 \text{ mm}^2/\text{sec}$.

e-NSC SERIES

OPERATING CHARACTERISTICS AT 50 Hz, 4 POLES

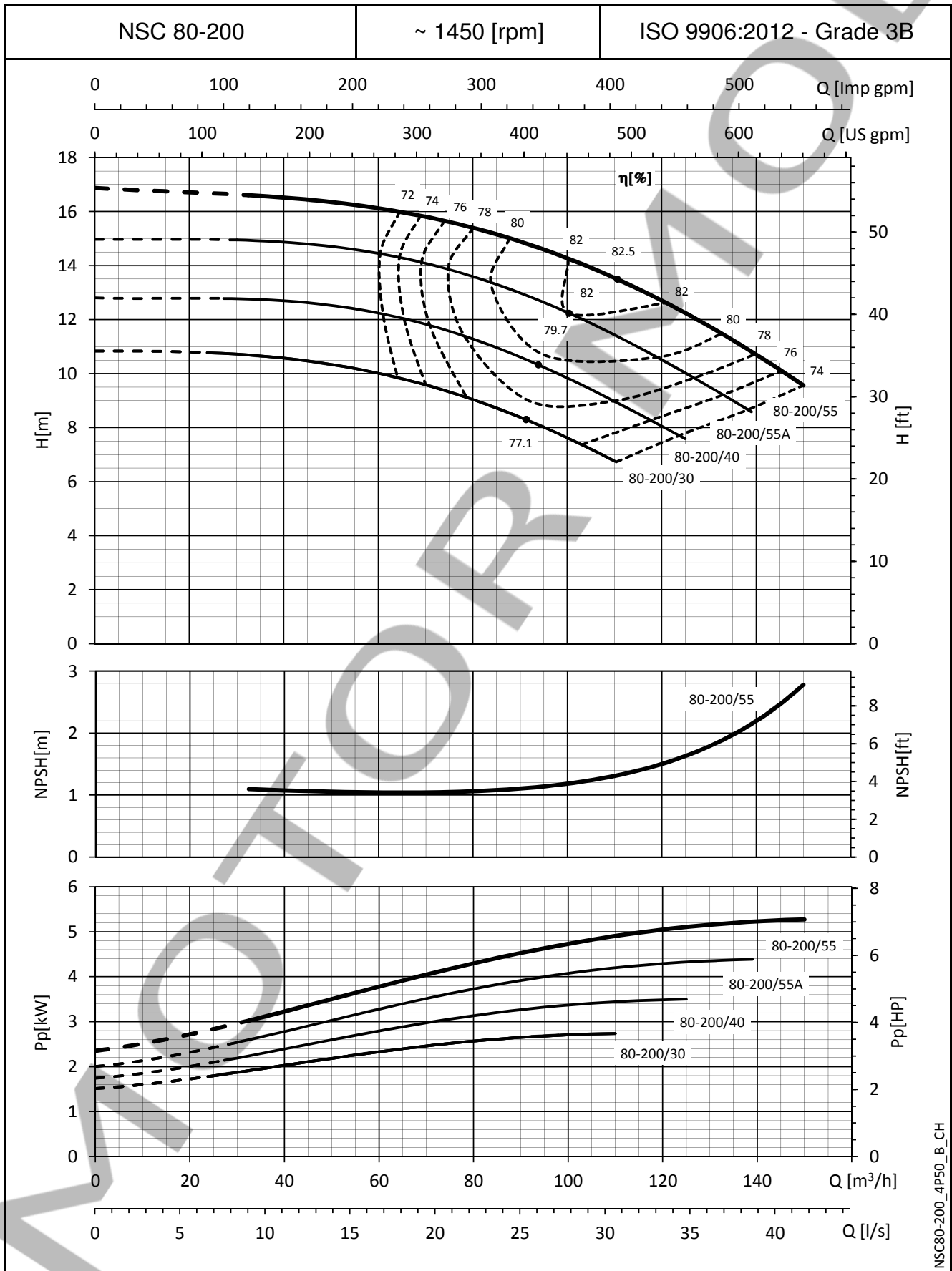

NSC80-200_4P50_B_CH

The NPSH values are laboratory values; for practical use we suggest increasing these values by 0,5 m.
 These performances are valid for liquids with density $\rho = 1,0 \text{ Kg/dm}^3$ and kinematic viscosity $\nu = 1 \text{ mm}^2/\text{sec}$.

e-NSC SERIES

OPERATING CHARACTERISTICS AT 50 Hz, 4 POLES

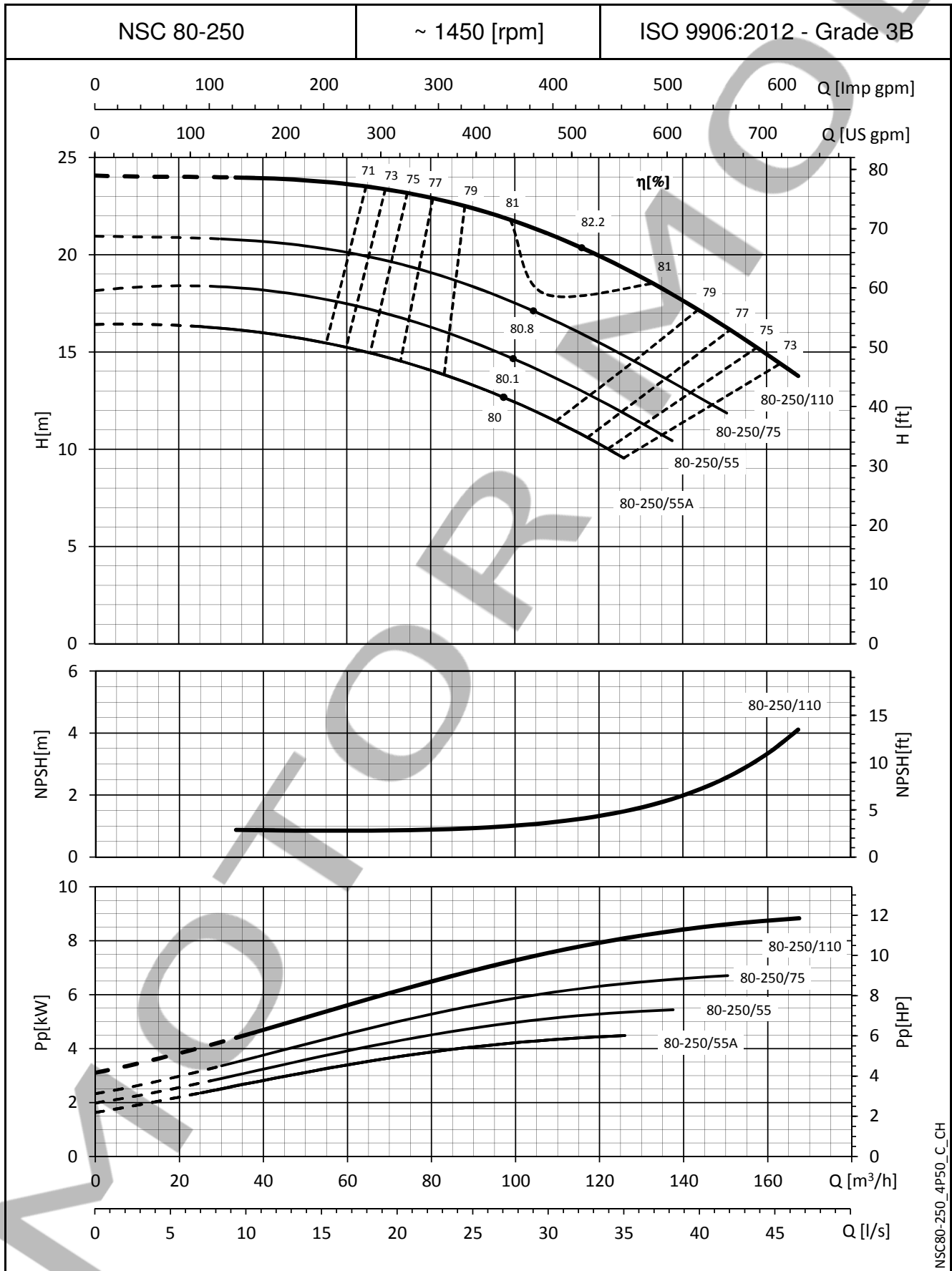

NSC80-250_4P50_C_CH

The NPSH values are laboratory values; for practical use we suggest increasing these values by 0,5 m.
 These performances are valid for liquids with density $\rho = 1,0 \text{ Kg/dm}^3$ and kinematic viscosity $\nu = 1 \text{ mm}^2/\text{sec}$.

e-NSC SERIES

OPERATING CHARACTERISTICS AT 50 Hz, 4 POLES

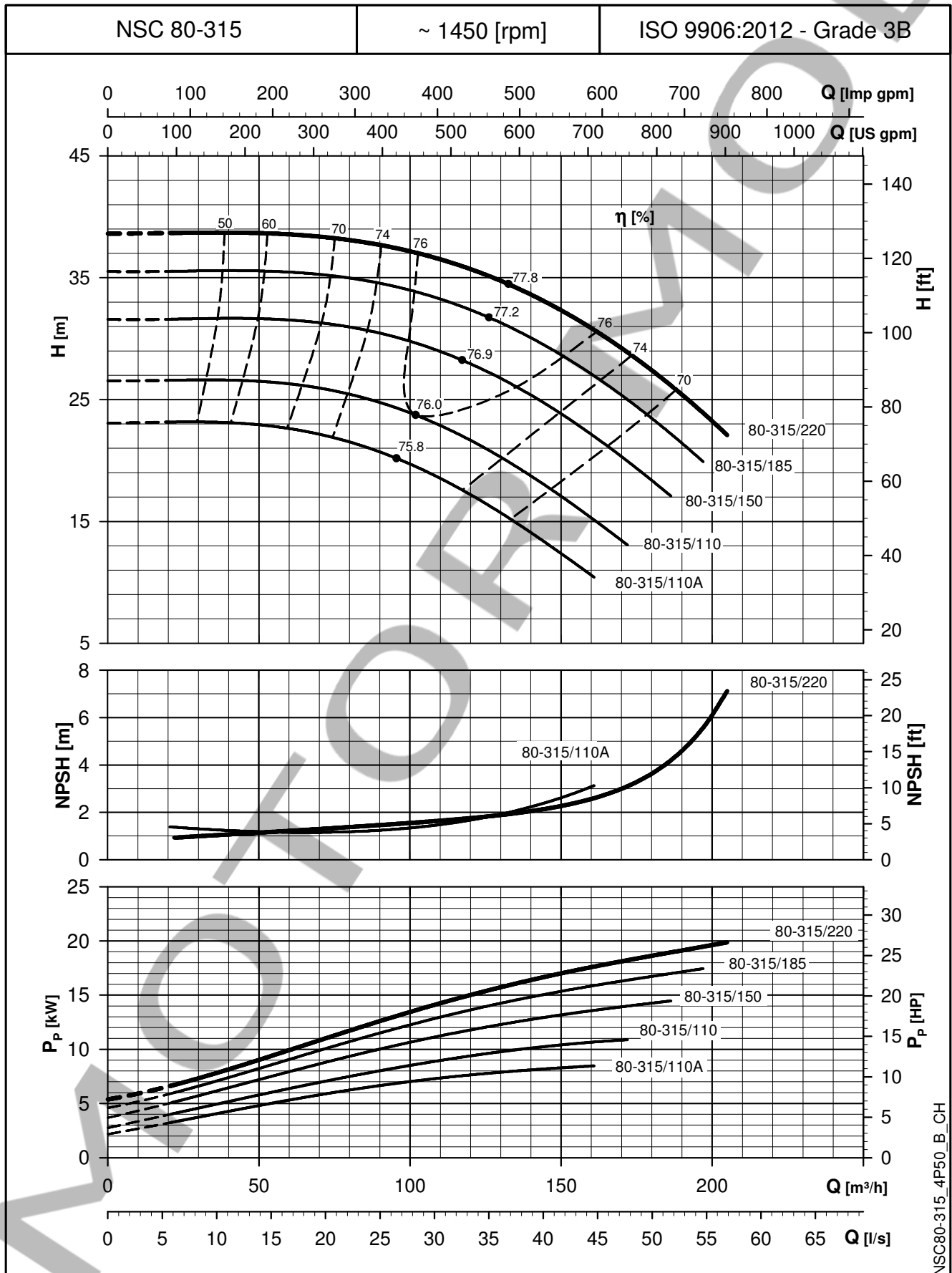

NSC80-315_4P50_B_CH

The NPSH values are laboratory values; for practical use we suggest increasing these values by 0,5 m.
 These performances are valid for liquids with density ρ = 1,0 Kg/dm³ and kinematic viscosity ν = 1 mm²/sec.

e-NSC SERIES

OPERATING CHARACTERISTICS AT 50 Hz, 4 POLES

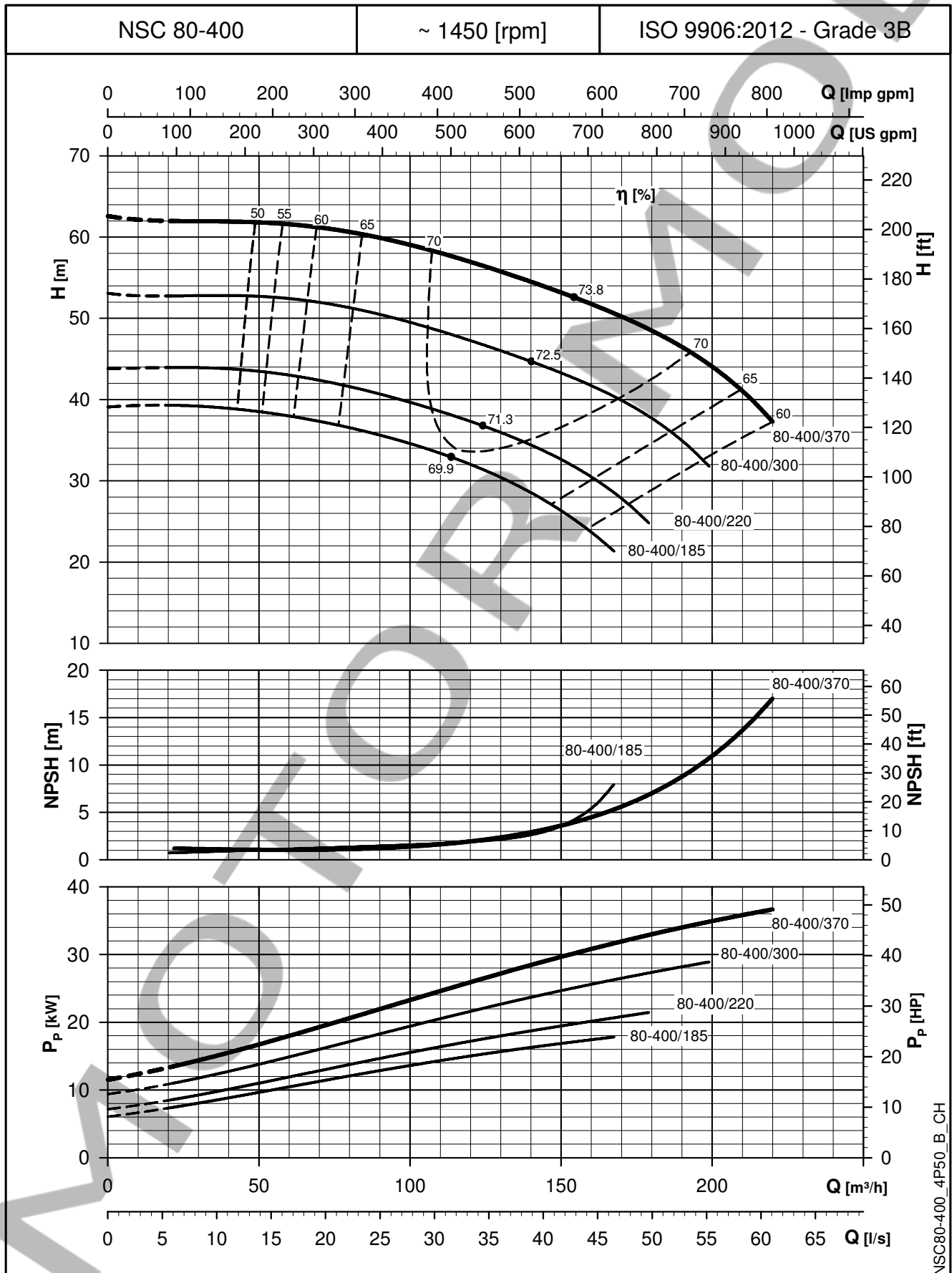

NSC80-400_4P50_B_CH

The NPSH values are laboratory values; for practical use we suggest increasing these values by 0,5 m.
 These performances are valid for liquids with density $\rho = 1,0 \text{ Kg/dm}^3$ and kinematic viscosity $\nu = 1 \text{ mm}^2/\text{sec}$.

NSCS 65, 80 SERIES
DIMENSIONS AND WEIGHTS AT 50 Hz, 4 POLES

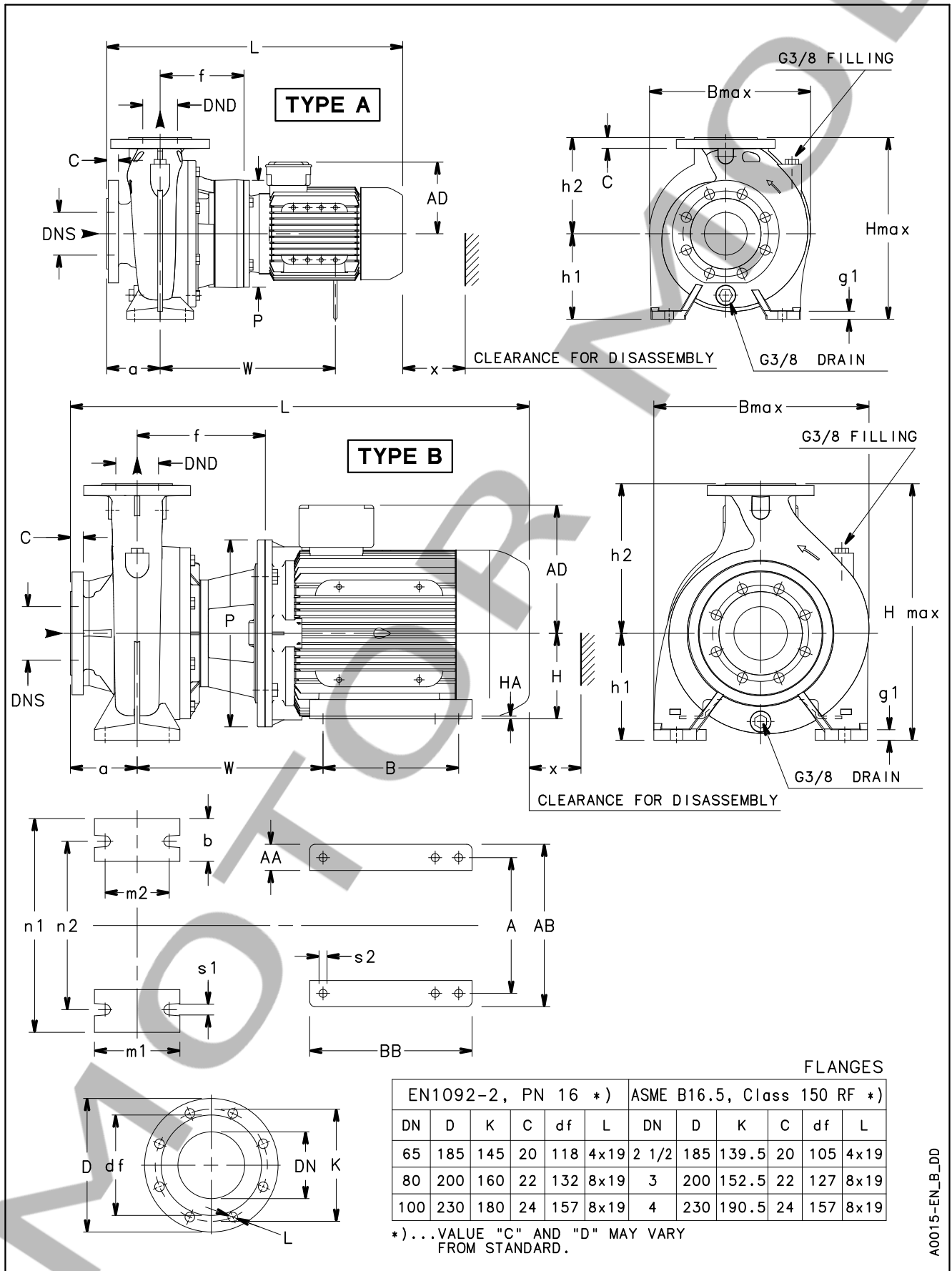

NSCS 65, 80 SERIES DIMENSIONS AND WEIGHTS AT 50 Hz, 4 POLES

POMPA TIPO NSCS..4	TIPO	DIMENSIONI (mm)																												PESO kg
		POMPA														MOTORE														
		DNS	DND	a	b	f	g1	h1	h2	m1	m2	n1	n2	P	s1	W	A	AA	AB	AD	B	BB	H	HA	s2	B max	H max	L	x	
65-125/05/S	A	80	65	100	65	157	16	160	180	125	95	280	212	200	14	292	-	-	-	139	-	-	-	-	-	300	340	520	100	44
65-125/07/X	A	80	65	100	65	157	16	160	180	125	95	280	212	200	14	-	-	-	128	-	-	-	-	-	300	340	488	100	48	
65-125/11/P	A	80	65	100	65	157	16	160	180	125	95	280	212	200	14	302	-	-	-	134	-	-	-	-	300	340	555	100	55	
65-125/15/P	A	80	65	100	65	157	16	160	180	125	95	280	212	200	14	302	-	-	-	134	-	-	-	-	300	340	555	100	58	
65-160/11A/P	A	80	65	100	65	155	16	160	200	125	95	280	212	200	14	300	-	-	-	134	-	-	-	-	335	360	553	108	59	
65-160/11/P	A	80	65	100	65	155	16	160	200	125	95	280	212	200	14	300	-	-	-	134	-	-	-	-	335	360	553	108	59	
65-160/15/P	A	80	65	100	65	155	16	160	200	125	95	280	212	200	14	300	-	-	-	134	-	-	-	-	335	360	553	108	62	
65-160/22A/P	A	80	65	100	65	165	16	160	200	125	95	280	212	250	14	350	-	-	-	168	-	-	-	-	335	360	587	108	72	
65-160/22/P	A	80	65	100	65	165	16	160	200	125	95	280	212	250	14	350	-	-	-	168	-	-	-	-	335	360	587	108	72	
65-200/15/P	A	80	65	100	65	155	16	180	225	125	95	320	250	200	14	300	-	-	-	134	-	-	-	-	348	405	553	118	65	
65-200/22A/P	A	80	65	100	65	165	16	180	225	125	95	320	250	250	14	350	-	-	-	168	-	-	-	-	348	405	587	118	75	
65-200/22/P	A	80	65	100	65	165	16	180	225	125	95	320	250	250	14	350	-	-	-	168	-	-	-	-	348	405	587	118	75	
65-200/30/P	A	80	65	100	65	165	16	180	225	125	95	320	250	250	14	350	-	-	-	168	-	-	-	-	348	405	618	118	78	
65-200/40/P	A	80	65	100	65	165	16	180	225	125	95	320	250	250	14	410	-	-	-	168	-	-	-	-	348	405	647	118	97	
65-250/30/P	A	80	65	100	80	183	21	200	250	160	120	360	280	250	20	368	-	-	-	168	-	-	-	-	367	450	636	130	85	
65-250/40/P	A	80	65	100	80	183	21	200	250	160	120	360	280	250	20	428	-	-	-	168	-	-	-	-	367	450	665	130	107	
65-250/55A/P	A	80	65	100	80	210	21	200	250	160	120	360	280	300	20	453	-	-	-	191	-	-	-	-	367	450	715	130	112	
65-250/55/P	A	80	65	100	80	210	21	200	250	160	120	360	280	300	20	453	-	-	-	191	-	-	-	-	367	450	715	130	112	
65-250/75/P	A	80	65	100	80	210	21	200	250	160	120	360	280	300	20	453	-	-	-	191	-	-	-	-	367	450	715	130	116	
65-315/55/P	A	80	65	125	80	210	20	225	280	160	120	400	315	300	19	452	-	-	-	218	-	-	-	-	437	505	707	140	153	
65-315/75/P	A	80	65	125	80	210	20	225	280	160	120	400	315	300	19	452	-	-	-	218	-	-	-	-	437	505	745	140	164	
65-315/110/P	B	80	65	125	80	240	20	225	280	160	120	400	315	350	19	348	254	64	308	264	210	254	160	22	15	437	505	853	140	205
65-315/150/P	B	80	65	125	80	240	20	225	280	160	120	400	315	350	19	348	254	64	308	264	210	298	160	22	15	437	505	897	140	227
80-160/15/P	A	100	80	125	65	155	16	180	225	125	95	320	250	200	14	300	-	-	-	134	-	-	-	-	340	405	578	122	72	
80-160/22A/P	A	100	80	125	65	165	16	180	225	125	95	320	250	250	14	350	-	-	-	168	-	-	-	-	340	405	612	122	82	
80-160/22/P	A	100	80	125	65	165	16	180	225	125	95	320	250	250	14	350	-	-	-	168	-	-	-	-	340	405	612	122	82	
80-160/30/P	A	100	80	125	65	165	16	180	225	125	95	320	250	250	14	350	-	-	-	168	-	-	-	-	340	405	643	122	85	
80-200/30/P	A	100	80	125	65	183	16	180	250	125	95	345	280	250	14	368	-	-	-	168	-	-	-	-	358	430	661	151	87	
80-200/40/P	A	100	80	125	65	183	16	180	250	125	95	345	280	250	14	428	-	-	-	168	-	-	-	-	358	430	690	151	109	
80-200/55A/P	A	100	80	125	65	210	16	180	250	125	95	345	280	300	14	453	-	-	-	191	-	-	-	-	358	430	740	151	115	
80-200/55/P	A	100	80	125	65	210	16	180	250	125	95	345	280	300	14	453	-	-	-	191	-	-	-	-	358	430	740	151	115	
80-250/55A/P	A	100	80	125	80	210	21	200	280	160	120	400	315	300	20	453	-	-	-	191	-	-	-	-	400	480	740	152	118	
80-250/55/P	A	100	80	125	80	210	21	200	280	160	120	400	315	300	20	453	-	-	-	191	-	-	-	-	400	480	740	152	118	
80-250/75/P	A	100	80	125	80	210	21	200	280	160	120	400	315	300	20	453	-	-	-	191	-	-	-	-	400	480	740	152	122	
80-250/110/P	B	100	80	125	80	240	21	200	280	160	120	400	315	350	20	348	254	49	304	240	254	304	160	5	15	400	480	859	152	185
80-315/110A/P	B	100	80	125	80	240	26	250	315	160	120	400	315	350	19	348	254	49	304	240	210	304	160	5	15	477	565	859	140	230
80-315/110/P	B	100	80	125	80	240	26	250	315	160	120	400	315	350	19	348	254	49	304	240	210	304	160	5	15	477	565	859	140	230
80-315/150/P	B	100	80	125	80	240	26	250	315	160	120	400	315	350	19	348	254	49	304	240	254	304	160	5	15	477	565	859	140	234
80-315/185/W	B	100	80	125	80	240	26	250	315	160	120	400	315	350	19	361	279	78	350	279	241	294	180	28	15	477	565	919	140	273
80-315/220/W	B	100	80	125	80	240	26	250	315	160	120	400	315	350	19	361	279	78	350	279	279	332	180	28	15	477	565	957	140	290
80-400/185/W	B	100	80	125	80	254	26	280	355	160	120	435	355	350	19	375	279	78	350	279	241	294	180	28	15	539	635	933	140	313
80-400/220/W	B	100	80	125	80	254	26	280	355	160	120	435	355	350	19	375	279	78	350	279	279	332	180	28	15	539	635	971	140	330
80-400/300/W	B	100	80	125	80	254	26	280	355	160	120	435	355	400	19	387	318	82	385	317	305	370	200	30	19	539	635	1036	140	374
80-400/370/W	B	100	80	125	80	284	26	280	355	160	120	435	355	450	19	433	356	80	436	384	286	412	225	34	19	539	664	1155	140	520

Per spessori e supporti vedere sezione accessori.

nscs-65-80-4p50_e_td

NOTA: Pompe con flange in accordo alle norme EN 1092-2; disponibile la versione ASME B16.5 su richiesta.