

50 Hz



e-NSC Series

HORIZONTAL CENTRIFUGAL ELECTRIC PUMPS
EQUIPPED WITH **IE3** MOTORS

ErP 2009/125/EC

Cod. 191002951 Rev. G Ed.07/2017

 **LOWARA**
a xylem brand

e-NSC 32, 40, 50 SERIES HYDRAULIC PERFORMANCE RANGE AT 50 Hz, 4 POLES

PUMP TYPE	P _N kW	Ø Impeller (mm)				Q = DELIVERY												
		STD (1)	B (2)	● (3)	η _p %	l/s 0	0,9	1,3	1,8	2,2	2,7	3,1	3,6	4,0	4,5	4,9	5,4	5,8
						m ³ /h 0	3	5	6	8	10	11	13	14	16	18	19	21
H = TOTAL HEAD METRES COLUMN OF WATER																		
32-125/02B	0,25	113	-	○	56,9	3,5	3,5	3,5	3,3	3,1	2,7	2,3						
32-125/02A	0,25	123	-	○	61,1	4,3		4,3	4,2	4,0	3,7	3,3	2,8	2,2				
32-125/02	0,25	133	-	○	63,4	5,3		5,4	5,3	5,1	4,9	4,5	4,1	3,6	2,9			
32-125/03	0,37	145	-	●	64,5	6,7			6,6	6,4	6,2	5,9	5,5	5,1	4,5	3,8	3,1	
32-160/02	0,25	137	-	○	58,5	5,5		5,5	5,4	5,1	4,8	4,3	3,7	3,0				
32-160/03	0,37	150	-	○	62,1	7,0		6,9	6,8	6,6	6,3	5,9	5,3	4,7	3,9			
32-160/05A	0,55	160,5	-	○	63,3	8,4		8,4	8,4	8,2	8,0	7,6	7,1	6,5	5,8	5,0	4,0	
32-160/05	0,55	171	-	●	63,4	9,5			9,5	9,3	9,1	8,8	8,3	7,8	7,1	6,2	5,3	4,2
32-200/05A	0,55	158	-	○	54,3	7,9		7,9	7,7	7,4	6,7	5,9	4,9					
32-200/05	0,55	171	-	○	56,5	9,5		9,4	9,3	9,0	8,5	7,7	6,8	5,7				
32-200/07	0,75	186	-	○	58,5	11,9		11,9	11,8	11,6	11,3	10,8	10,0	9,1	7,9			
32-200/11	1,1	205	-	●	60,6	15,1			15,0	14,9	14,7	14,4	13,9	13,2	12,2	11,0		
NSC2 32-250/11A	1,10	177	-	○	47,3	18,7		17,0	16,1	14,8	13,3	11,5	9,6					
NSC2 32-250/11	1,1	195	-	●	50,0	23,3		21,6	20,8	19,7	18,2	16,4	14,3	12,0				
32-250/11A	1,1	214	-	○	44,4	14,5			14,1	13,7	13,1	12,2	11,1					
32-250/15B	1,5	214	-	○	44,4	14,5			14,1	13,7	13,1	12,2	11,1					
32-250/11	1,1	226,5	-	○	45,7	16,3			15,9	15,5	15,0	14,2	13,2	11,9				
32-250/15A	1,5	226,5	-	○	45,7	16,3			15,9	15,5	15,0	14,2	13,2	11,9				
32-250/15	1,5	239	-	○	46,1	18,7				17,8	17,3	16,6	15,7	14,5	13,0			
32-250/22	2,2	259	-	●	46,7	22,6				21,9	21,5	20,9	20,2	19,3	18,1	16,6	14,6	

PUMP TYPE	P _N kW	Ø Impeller (mm)				Q = DELIVERY												
		STD (1)	B (2)	● (3)	η _p %	l/s 0	1,3	2,1	2,8	3,6	4,3	5,0	5,8	6,5	7,2	8,0	8,7	9,4
						m ³ /h 0	5	7	10	13	15	18	21	23	26	29	31	34
H = TOTAL HEAD METRES COLUMN OF WATER																		
40-125/02A	0,25	105	-	○	66,1	3,6	3,6	3,5	3,4	3,1	2,8	2,4						
40-125/02	0,25	118	-	○	70,5	4,6		4,4	4,3	4,1	3,8	3,4	2,9					
40-125/03	0,37	130	-	○	73,3	5,6		5,5	5,4	5,3	5,0	4,7	4,3	3,8	3,2			
40-125/05	0,55	135	-	●	74,0	6,5			6,3	6,1	5,9	5,6	5,2	4,8	4,3	3,7		
40-160/03	0,37	127	-	○	66,6	5,2		5,3	5,2	5,0	4,6	4,1	3,6					
40-160/05	0,55	139	-	○	69,0	6,6		6,6	6,6	6,4	6,2	5,8	5,3	4,7				
40-160/07	0,75	154	-	○	70,8	8,3		8,4	8,4	8,4	8,2	7,9	7,6	7,1	6,4	5,7		
40-160/11	1,1	165	-	●	71,1	10,1			10,1	10,0	9,9	9,6	9,3	8,9	8,4	7,8	7,0	
40-200/07	0,75	165	-	○	59,5	9,0		8,9	8,8	8,6	8,2	7,5	6,5	5,2				
40-200/11	1,1	179	-	○	60,6	10,9		11,0	11,0	10,9	10,6	10,1	9,3	8,2	6,9			
40-200/15A	1,5	189	-	○	60,9	12,4			12,5	12,4	12,2	11,7	11,1	10,2	9,0	7,4		
40-200/15	1,5	199	-	●	62,8	14,0			14,0	13,9	13,6	13,3	12,8	12,0	11,1	9,8	8,3	6,4
40-250/11	1,1	199	-	○	57,9	13,5			13,3	12,9	12,4	11,6	10,6					
40-250/15A	1,5	199	-	○	57,9	13,5			13,3	12,9	12,4	11,6	10,6					
40-250/15	1,5	210	-	○	58,8	15,1			14,9	14,7	14,3	13,6	12,7	11,6				
40-250/22A	1,5	228	-	○	59,1	18,0			18,0	17,8	17,5	17,1	16,4	15,5	14,3			
40-250/22	2,2	243	-	○	60,4	20,6				20,5	20,3	19,9	19,4	18,6	17,6	16,4		
40-250/30	3	257,5	-	●	63,9	24,4				24,1	23,9	23,6	23,1	22,5	21,6	20,6	19,2	

PUMP TYPE	P _N kW	Ø Impeller (mm)				Q = DELIVERY												
		STD (1)	B (2)	● (3)	η _p %	l/s 0	2,3	3,9	5,5	7,2	8,8	10,4	12,0	13,6	15,2	16,8	18,4	20,0
						m ³ /h 0	8	14	20	26	32	37	43	49	55	60	66	72
H = TOTAL HEAD METRES COLUMN OF WATER																		
50-125/03	0,37	118	-	○	67,5	4,1		3,7	3,4	3,0	2,4	1,7						
50-125/05	0,55	130	-	○	69,8	5,2		4,8	4,5	4,1	3,5	2,8	2,0					
50-125/07	0,75	144	-	○	71,0	6,7		6,3	6,0	5,7	5,2	4,6	3,9	3,0				
50-125/11	1,1	148	-	●	74,6	7,6		7,2	7,0	6,7	6,3	5,8	5,2	4,4	3,6			
50-160/07	0,75	144	-	○	69,9	6,8		6,4	6,1	5,6	4,9	4,1						
50-160/11A	1,1	159	-	○	70,4	8,4		8,1	7,8	7,3	6,7	5,9	4,9					
50-160/11	1,1	170	-	○	71,8	9,6		9,3	9,0	8,6	8,0	7,3	6,4	5,4				
50-160/15	1,5	176	-	●	72,3	10,8		10,3	10,0	9,7	9,2	8,5	7,7	6,7	5,5			
50-200/11	1,1	168	-	○	68,9	8,9		9,1	9,0	8,7	8,0	6,9						
50-200/15A	1,5	168	-	○	68,9	8,9		9,1	9,0	8,7	8,0	6,9						
50-200/15	1,5	179	-	○	70,5	10,4		10,6	10,6	10,3	9,7	8,7	7,4					
50-200/22A	2,2	197	-	○	72,0	13,1		13,3	13,3	13,1	12,6	11,8	10,7	9,2				
50-200/22	2,2	209	-	●	73,3	15,1		15,1	15,1	14,8	14,4	13,7	12,7	11,4				
50-250/22A	2,2	208	-	○	67,2	14,7		14,6	14,3	13,6	12,6	11,1	9,0					
50-250/22	2,2	220	-	○	68,3	16,6		16,5	16,2	15,7	14,7	13,3	11,4					
50-250/30	3	232	-	○	68,5	18,7		18,6	18,3	17,8	16,9	15,7	13,9	11,6				
50-250/40	4	256	-	●	68,6	22,8			22,6	22,2	21,6	20,5	19,0	17,1	14,6			
50-315/40	4	265	-	○	60,0	22,6	22,5	22,2	21,7	21,0	20,2	19,2	17,9	16,1				
50-315/55	5,5	278	-	○	61,1	27,4		27,0	26,6	25,9	25,1	24,1	23,0	21,7	19,8	17,0		
50-315/75	7,5	304	-	○	63,2	33,3		33,1	32,8	32,2	31,4	30,4	29,4	28,3	27,0	25,2	22,5	
50-315/110	11	322	-	●	63,3	37,6		37,3	37,0	36,5	35,9	35,1	34,1	32,9	31,5	29,7	27,5	24,8

Hydraulic performances in compliance with ISO 9906:2012 - Grade 3B (ex ISO 9906:1999 - Annex A)

Nsc-32-40-50_4p50-en_d_th

(1) STD = Cast iron/Stainless steel - B = Bronze (2) ● = Full impeller diameter - ○ = Trimmed impeller diameter (3) Hydraulic efficiency of pump.

e-NSC 65, 80 SERIES HYDRAULIC PERFORMANCE RANGE AT 50 Hz, 4 POLES

PUMP TYPE	P _N kW	Ø Impeller (mm)				Q = DELIVERY												
		STD (1)	B (2)	O (3)	η _p %	l/s	3,3	6,3	9,3	12,2	15,2	18,2	21,2	24,2	27,2	30,1	33,1	36,1
						m ³ /h	0	12	23	33	44	55	66	76	87	98	109	119
H = TOTAL HEAD METRES COLUMN OF WATER																		
65-125/05	0,55	113	112	○	75,0	3,5		3,4	3,1	2,7	2,1							
65-125/07	0,75	127	126	○	77,0	4,9		4,7	4,4	3,9	3,2	2,4						
65-125/11	1,1	137	136	○	78,3	5,8		5,8	5,6	5,1	4,5	3,6	2,7					
65-125/15	1,5	148	146	●	79,5	7,2		7,1	6,9	6,5	6,0	5,4	4,6	3,6				
65-160/11A	1,1	145	144	○	77,1	6,4		6,4	6,0	5,4	4,4	3,4						
65-160/15B	1,5	145	144	○	77,1	6,4		6,4	6,0	5,4	4,4	3,4						
65-160/11	1,1	151	152	○	78,0	7,2		7,0	6,7	6,1	5,2	4,1						
65-160/15A	1,5	151	152	○	78,0	7,2		7,0	6,7	6,1	5,2	4,1						
65-160/15	1,5	159	160	○	79,6	8,2		8,0	7,7	7,1	6,3	5,3						
65-160/22A	2,2	175	176	○	81,8	10,2		10,1	9,9	9,4	8,8	7,9	6,8	5,6				
65-160/22	2,2	180	180	●	82,1	10,9		10,8	10,5	10,0	9,3	8,4	7,4	6,1				
65-200/15	1,5	165	162	○	73,1	8,9	8,9	8,7	8,2	7,2	5,7							
65-200/22A	2,2	177	177	○	74,6	10,6		10,5	10,0	9,2	7,8	6,0						
65-200/22	2,2	189	189	○	76,9	12,1		12,0	11,6	10,8	9,6	7,9	5,7					
65-200/30	3	199	199	○	78,0	13,6		13,6	13,2	12,6	11,5	9,9	7,8					
65-200/40	4	220	218	●	80,0	17,0		16,9	16,7	16,1	15,3	14,1	12,5	10,3				
65-250/30	3	195	192	○	73,9	12,6		13,2	12,8	12,0	10,8	9,3	7,3					
65-250/40	4	215	213	○	74,3	15,7		16,2	15,8	15,1	14,1	12,7	11,0	8,9				
65-250/55A	5,5	229	226	○	76,0	18,1		19,0	18,7	18,1	17,3	16,1	14,6	12,8	10,5			
65-250/55	5,5	243	240	○	77,2	20,7		21,3	21,2	20,7	20,0	18,9	17,5	15,8	13,7			
65-250/75	7,5	258	255	●	77,6	24,3		24,6	24,3	23,8	23,0	22,0	20,8	19,2	17,4	15,2		
65-315/55	5,5	260	260	○	68,1	22,7		22,4	21,7	20,8	19,6	18,0	15,7	12,7				
65-315/75	7,5	285	285	○	70,4	27,6		27,3	26,8	26,0	24,8	23,3	21,4	18,9	15,9			
65-315/110	11	315	315	○	71,4	34,7		34,5	34,0	33,3	32,3	31,0	29,3	27,2	24,6	21,4	17,3	
65-315/150	15	334	334	●	72,2	39,0		38,9	38,5	37,8	36,8	35,5	33,9	32,0	29,7	27,0	23,8	20,3

PUMP TYPE	P _N kW	Ø Impeller (mm)				Q = DELIVERY												
		STD (1)	B (2)	O (3)	η _p %	l/s	5,6	10,7	15,7	20,8	25,8	30,9	35,9	40,9	46,0	51,0	56,1	61,1
						m ³ /h	0	20	38	57	75	93	111	129	147	166	184	202
H = TOTAL HEAD METRES COLUMN OF WATER																		
80-160/15	1,5	144	144	○	72,1	6,5		6,2	5,5	4,5	3,5							
80-160/22A	2,2	158	158	○	78,4	8,3		7,9	7,3	6,5	5,4	4,2						
80-160/22	2,2	168	168	○	79,0	9,3		9,0	8,5	7,6	6,5	5,2	3,8					
80-160/30	3	177	177	●	81,2	10,5		10,2	9,8	9,0	8,0	6,7	5,3					
80-200/30	3	181	177	○	77,1	10,8		10,6	10,1	9,3	8,2							
80-200/40	4	195	192	○	79,7	12,8		12,7	12,4	11,6	10,4	8,9						
80-200/55A	5,5	208	204	○	82,0	15,0		14,9	14,5	13,9	12,8	11,3						
80-200/55	5,5	219	216	●	82,5	16,9		16,5	16,2	15,6	14,7	13,5	11,8					
80-250/55A	5,5	214	211	○	80,0	16,4		16,0	15,4	14,4	13,1	11,3	9,1	6,5				
80-250/55	5,5	227	224	○	80,1	18,2		18,2	17,6	16,6	15,3	13,5						
80-250/75	7,5	241	238	○	80,8	21,0		20,7	20,2	19,4	18,1	16,4	14,4					
80-250/110	11	259	256	●	82,2	24,1		23,9	23,7	23,2	22,2	20,8	19,0	16,7				
80-315/110A	11	262	262	○	75,8	23,1		23,1	22,7	21,9	20,4	18,4	15,8	12,8	9,6			
80-315/110	11	280	280	○	76,0	26,6		26,6	26,4	25,7	24,5	22,8	20,4	17,5				
80-315/150	15	304	304	○	76,9	31,6		31,7	31,6	31,2	30,3	28,9	26,8	24,3	21,2			
80-315/185	18,5	321	321	○	77,2	35,5		35,6	35,5	35,2	34,4	33,2	31,4	29,1	26,2	22,7		
80-315/220	22	334	334	●	77,8	38,6		38,7	38,6	38,3	37,6	36,4	34,8	32,7	30,0	26,7		
80-400/185	18,5	338	338	○	69,9	39,1		39,0	38,2	37,0	35,3	33,3	30,6	27,0	22,0	15,0	5,1	
80-400/220	22	356	356	○	71,3	43,8	44,0	43,8	43,2	42,0	40,4	38,4	36,1	33,1	29,1			
80-400/300	30	388	388	○	72,5	53,1		52,8	52,6	51,7	50,2	48,3	46,1	43,7	40,8			
80-400/370	37	418	418	●	73,8	62,6		61,9	61,7	61,0	59,7	57,9	55,9	53,5	50,9	47,8		

Hydraulic performances in compliance with ISO 9906:2012 - Grade 3B (ex ISO 9906:1999 - Annex A)

Nsc-65-80_4p50-en_d_th

(1) STD = Cast iron/Stainless steel - B = Bronze (2) ● = Full impeller diameter - ○ = Trimmed impeller diameter (3) Hydraulic efficiency of pump.

e-NSC 100-125-150 SERIES HYDRAULIC PERFORMANCE RANGE AT 50 Hz, 4 POLES

PUMP TYPE	P _N kW	Ø Impeller (mm)				Q = DELIVERY												
		STD	B	●	η _p %	l/s	5.6	12.6	19.7	26.8	33.8	40.9	48.0	55.1	62.1	69.2	76.3	83.3
						m ³ /h	0	20	45	71	96	122	147	173	198	224	249	275
H = TOTAL HEAD METRES COLUMN OF WATER																		
100-160/22A	2.2	144	144	○	75.9	5.9		5.9	5.6	4.9	3.7							
100-160/22	2.2	156	156	○	77.4	6.9		6.9	6.6	6.0	4.8	3.5						
100-160/30	3	176	176	○	81.5	9.1		9.0	8.8	8.1	7.0	5.6	4.0					
100-160/40	4	190	190	●	83.6	10.8		10.6	10.4	9.8	8.9	7.6	6.0					
100-200/40	4.0	197	197	○	82.6	12.2		12.1	11.8	11.0	9.6	7.5	5.1					
100-200/55	5.5	213	213	○	83.8	14.8		14.6	14.5	13.8	12.6	10.7	8.4					
100-200/75	7.5	227	227	●	84.3	16.9		16.7	16.5	15.9	14.8	13.1	11.0	8.4				
100-250/55	5.5	213	213	○	80.6	14.1		14.1	13.8	13.1	11.9	10.1	8.0					
100-250/75	7.5	237	237	○	83.1	17.8		17.9	17.7	17.2	16.2	14.6	12.5	10.1				
100-250/110	11	259	259	●	84.1	21.9		21.9	21.7	21.1	20.0	18.4	16.3	13.8				
100-315/110	11	260	260	○	78.9	23.5	23.5	23.4	23.1	22.4	21.1	19.2	16.5	12.6				
100-315/150	15	284	284	○	79.5	28.0		28.0	27.8	27.2	26.0	24.4	22.4	19.5				
100-315/185	18.5	298	298	○	79.9	31.1		31.0	30.9	30.3	29.3	27.8	26.1	23.8	20.4			
100-315/220	22	312	312	○	80.6	34.3		34.2	34.1	33.7	32.8	31.4	29.6	27.6	25.0			
100-315/300	30	334	334	●	80.8	40.2		40.1	40.1	39.7	38.8	37.6	36.0	34.0	31.5	28.2		
100-400/300	30	375	375	○	76.8	47.4		46.5	45.8	44.9	43.7	42.1	40.0	37.4	34.3	30.6		
100-400/370	37	397	397	○	77.1	54.4		53.3	52.5	51.6	50.4	48.9	47.1	44.8	42.0	38.6	34.7	
100-400/450	45	420	420	●	76.9	61.3		60.0	59.4	58.6	57.3	55.7	53.8	51.6	49.0	45.8	42.0	37.3

PUMP TYPE	P _N kW	Ø Impeller (mm)				Q = DELIVERY												
		STD	B	●	η _p %	l/s	11.9	21.4	30.9	40.5	50.0	59.5	69.0	78.6	88.1	97.6	107.1	116.7
						m ³ /h	0	43	77	111	146	180	214	249	283	317	351	386
H = TOTAL HEAD METRES COLUMN OF WATER																		
125-200/55	5.5	179	179	○	80.9	8.6		8.4	8.4	8.3	8.0	7.2	6.0					
125-200/75	7.5	204	204	○	83.5	11.9		11.8	11.8	11.6	11.2	10.3	9.0	7.5				
125-200/110	11	225	225	●	85.4	15.0		14.9	14.9	14.8	14.4	13.7	12.6	11.1	9.3			
125-250/75	7.5	210	210	○	84.5	13.6	13.5	13.4	13.3	12.9	12.1	10.6	8.6	6.3				
125-250/110	11	235	235	○	86.3	17.5		17.4	17.4	17.2	16.6	15.3	13.5	11.3	9.2			
125-250/150	15	259	259	●	88.3	22.0		21.7	21.7	21.5	21.0	20.0	18.5	16.5	14.1	11.6		
125-315/185	18.5	277	277	○	83.7	25.6		25.7	25.6	25.3	24.4	22.8	20.1	16.4	11.9	7.3		
125-315/220	22	290	290	○	84.3	28.3		28.6	28.5	28.2	27.5	26.1	23.8	20.7	16.6			
125-315/300	30	315	315	○	85.4	34.8		35.1	35.0	34.8	34.1	33.0	31.4	29.1	26.0	22.1		
125-315/370	37	334	334	●	86.4	39.6		39.8	39.9	39.7	39.2	38.2	36.8	34.8	32.1	28.7	24.6	
125-400/370	37	353	353	○	78.0	43.4		43.9	43.8	43.2	41.9	39.9	37.0	33.0	28.0			
125-400/450	45	374	374	○	78.8	48.7		49.4	49.6	49.3	48.3	46.4	43.7	40.0	35.4	30.0		
125-400/550	55	394	394	○	79.1	54.4		55.6	55.8	55.5	54.6	53.0	50.7	47.6	43.6	38.7		
125-400/750	75	422	422	●	79.9	63.4		64.8	64.7	64.2	63.3	61.8	59.8	57.1	53.8	49.8	45.0	39.3

PUMP TYPE	P _N kW	Ø Impeller (mm)				Q = DELIVERY												
		STD	B	●	η _p %	l/s	16.7	33.8	51.0	68.2	85.4	102.5	119.7	136.9	154.0	171.2	188.4	205.6
						m ³ /h	0	60	122	184	245	307	369	431	493	555	616	678
H = TOTAL HEAD METRES COLUMN OF WATER																		
150-200/110A	11	200	200	○	78.8	11.8		11.3	10.5	9.4	8.3	7.0	5.4					
150-200/110	11	217	217	○	80.7	14.0		13.4	12.5	11.4	10.1	8.7	7.0	4.9				
150-200/150A	15	227	227	○	82.0	15.2		14.5	13.8	12.9	11.7	10.2	8.4	6.4				
150-200/150	15	237	237	●	83.9	16.3		15.6	15.1	14.4	13.4	12.0	10.3	8.2				
150-250/150	15	238	238	○	80.3	17.2	17.0	16.7	16.1	15.1	13.7	11.6	9.1					
150-250/185	18.5	253	253	○	82.7	19.8		19.1	18.7	17.9	16.6	14.8	12.4	9.5				
150-250/220	22	265	265	○	84.6	22.1		21.4	21.0	20.4	19.3	17.6	15.4	12.6				
150-250/300	30	282	282	●	86.2	26.4		25.3	24.7	23.9	22.9	21.5	19.6	17.3	14.4			
150-315/300	30	291	291	○	84.2	27.7		27.7	27.6	27.0	25.7	23.5	20.4	16.5				
150-315/370	37	310	310	○	85.1	31.9		31.8	31.6	31.1	30.0	28.1	25.3	21.5	17.1			
150-315/450	45	330	330	●	86.3	36.6		36.2	36.1	35.7	34.7	32.9	30.4	27.2	23.2			
150-400/450	45	327	327	○	81.8	36.7		36.9	36.6	35.6	34.0	31.7	28.6	24.6				
150-400/550	55	346	346	○	84.4	41.2		41.6	41.5	40.9	39.5	37.5	34.6	30.9	26.3			
150-400/750	75	377	377	○	84.9	50.3		50.8	50.9	50.4	49.1	47.0	44.4	41.3	37.7	33.3		
150-400/900	90	398	398	○	85.3	56.5		56.9	57.0	56.5	55.5	53.7	51.4	48.5	45.1	41.0		
150-400/1100	110	423	423	●	85.5	63.9		64.4	64.3	63.9	63.0	61.5	59.4	56.6	53.2	49.1	44.4	
150-500/900	90	420	420	○	75.1	60.9		61.6	61.8	61.1	59.0	55.2	49.6	42.6	34.5			
150-500/1100	110	443	443	○	75.4	68.5		68.9	69.3	69.0	67.5	64.4	59.5	52.7	44.6	36.1		
150-500/1320	132	467	467	○	76.5	76.9		77.6	78.1	78.0	76.9	74.3	70.1	64.0	56.3	47.3		
150-500/1600	160	495	495	○	77.9	87.0		87.9	88.4	88.5	87.8	86.0	82.7	77.6	70.7	62.1	52.6	
150-500/2000	200	516	516	●	78.6	95.1		95.9	96.5	96.7	96.1	94.4	91.4	86.7	80.4	72.6	63.5	53.7

Hydraulic performances in compliance with ISO 9906:2012 - Grade 3B (ex ISO 9906:1999 - Annex A)

Nsc-100-150_4p50-en_c_th

(1) STD = Cast iron/Stainless steel - B = Bronze (2) ● = Full impeller diameter - ○ = Trimmed impeller diameter (3) Hydraulic efficiency of pump.

e-NSC 200-250-300 SERIES

HYDRAULIC PERFORMANCE RANGE AT 50 Hz, 4 POLES

PUMP TYPE	P _N kW	Ø Impeller (mm)				Q = DELIVERY												
		STD (1)	B (2)	● (3)	η _p % (3)	Vs 0 m ³ /h 0	38,1 137	62,4 225	86,7 312	111,0 400	135,3 487	159,6 575	184,0 662	208,3 750	232,6 837	256,9 925	281,2 1012	305,6 1100
H = TOTAL HEAD METRES COLUMN OF WATER																		
200-250/185	18,5	228	228	○	78,6	15,7	15,3	14,8	13,7	12,2	10,6	8,9	6,8					
200-250/220	22	245	245	○	81,6	18,5		17,2	16,2	14,8	13,1	11,1	8,7					
200-250/300A	30	260	260	○	83,9	21,2		19,7	18,7	17,4	15,8	13,7	11,2	8,4				
200-250/300	30	271	271	●	85,0	23,1		21,5	20,5	19,4	17,9	16,0	13,6	10,8				
200-315/300	30	268	268	○	80,7	22,1	21,7	21,3	20,7	19,6	17,7	14,9	11,3					
200-315/450	37	287	287	○	82,9	25,3		24,6	24,2	23,3	21,7	19,3	15,9	11,8				
200-315/370	45	306	306	○	84,8	29,0		28,3	28,1	27,4	26,1	23,9	20,8	16,8	12,3			
200-315/550	55	328	328	○	86,1	34,1		33,2	32,8	32,1	30,9	28,8	26,0	22,2	17,8			
200-315/750	75	333	333	●	86,3	35,1		34,3	34,0	33,3	32,0	29,9	27,1	23,4	19,1			
200-400/750A	75	328	328	○	83,4	37,2		37,0	36,7	35,7	33,8	31,0	27,0	22,0				
200-400/750	75	342	342	○	83,5	41,0		40,6	40,3	39,4	37,7	35,0	31,3	26,5				
200-400/900	90	362	362	○	84,2	46,5		46,0	45,7	44,9	43,4	41,1	37,7	33,3	27,9			
200-400/1100	110	383	383	○	85,4	52,4		52,2	51,9	51,2	50,0	48,0	45,1	41,2	36,2			
200-400/1320	132	409	409	●	85,5	60,1		59,8	59,6	59,0	57,9	56,1	53,5	50,0	45,4	39,6		
200-500/1320	132	425	425	○	80,5	64,3		64,4	63,7	62,5	60,2	56,4	50,8	43,3	34,2			
200-500/1600	160	450	450	○	81,2	72,8		72,7	72,2	71,0	69,0	65,8	61,2	55,0	46,9			
200-500/2000	200	480	480	○	82,6	83,8		83,6	83,1	82,1	80,3	77,7	74,0	69,1	62,5	53,8		
200-500/2500	250	508	508	○	83,0	94,3		93,8	93,3	92,3	90,7	88,3	85,1	81,0	75,8	69,2	60,7	
200-500/3150	315	523	523	●	83,3	100,3		99,6	99,1	98,1	96,4	94,1	91,0	87,2	82,5	76,6	69,1	59,6

PUMP TYPE	P _N kW	Ø Impeller (mm)				Q = DELIVERY												
		STD (1)	B (2)	● (3)	η _p % (3)	Vs 0 m ³ /h 0	61,9 223	94,2 339	126,4 455	158,7 571	190,9 687	223,2 803	255,4 920	287,7 1036	319,9 1152	352,2 1268	384,4 1384	416,7 1500
H = TOTAL HEAD METRES COLUMN OF WATER																		
250-315/370	37	255	255	○	81,1	19,4	19,2	18,5	17,7	16,7	15,3	13,3	10,4					
250-315/450	45	273	273	○	83,1	22,7		21,8	21,0	20,1	18,9	16,9	13,8	10,0				
250-315/550	55	290	290	○	84,5	26,1		24,8	24,3	23,6	22,6	20,7	18,0	14,5				
250-315/750	75	316	316	●	85,7	31,5		29,9	29,5	29,1	28,4	27,1	25,0	22,1	18,6			
250-400/750	75	325	325	○	82,0	35,4		35,2	34,3	32,5	29,9	26,3	21,8	16,4				
250-400/900	90	344	344	○	82,9	39,8		39,8	39,2	37,9	35,6	32,3	27,9	22,5				
250-400/1100	110	365	365	○	84,0	45,1		45,0	44,8	43,8	42,0	39,1	35,1	30,0	23,9			
250-400/1320	132	386	386	○	85,1	50,8		50,6	50,4	49,7	48,1	45,6	42,0	37,3	31,5			
250-400/1600	160	407	407	○	85,8	56,9		56,4	56,2	55,6	54,2	52,0	48,9	44,7	39,4	33,0		
250-400/2000	200	425	425	●	86,5	62,7		62,0	61,6	60,9	59,6	57,6	54,9	51,2	46,5	40,6		
250-500/1600	160	420	420	○	82,3	61,1		61,6	60,8	59,2	56,4	52,2	46,3	38,1				
250-500/2000	200	448	448	○	84,5	70,3		71,0	70,7	69,6	67,6	64,1	59,0	51,8	42,3			
250-500/2500	250	477	477	○	84,6	80,5		81,0	80,6	79,7	78,2	75,6	71,8	66,3	58,8	48,9		
250-500/3150	315	508	508	○	84,9	92,6		93,3	92,7	91,6	90,0	87,6	84,5	80,3	74,8	67,8	58,9	
250-500/3550	355	523	523	●	85,0	98,3		99,0	98,4	97,3	95,7	93,6	90,6	86,8	81,9	75,7	68,0	58,5

PUMP TYPE	P _N kW	Ø Impeller (mm)				Q = DELIVERY												
		STD (1)	B (2)	● (3)	η _p % (3)	Vs 0 m ³ /h 0	92,8 334	132,3 476	171,9 619	211,4 761	251,0 903	290,5 1046	330,1 1188	369,6 1331	409,1 1473	448,7 1615	488,2 1758	527,8 1900
H = TOTAL HEAD METRES COLUMN OF WATER																		
300-350/750A	75	285	285	○	79,0	24,4		22,4	21,4	20,0	18,3	16,3	13,9	11,3	8,2			
300-350/750	75	315	315	○	82,2	30,5		28,1	26,8	25,3	23,4	21,2	18,7	15,9	12,7	9,1		
300-350/900	90	332	332	○	83,2	34,7		32,0	30,7	29,1	27,3	25,2	22,7	19,9	16,8	13,3		
300-350/1100	110	354	354	●	85,8	39,7		37,1	36,0	34,6	32,9	30,9	28,5	25,8	22,7	19,2	15,4	
300-400/1100	110	346	346	○	88,2	36,2		36,3	35,9	34,9	33,2	30,8	27,6	23,7	19,1			
300-400/1320	132	367	367	○	87,5	41,9		41,4	41,0	40,2	38,8	36,6	33,6	29,7	25,0	19,7		
300-400/1600	160	390	390	○	86,0	48,0		47,2	46,9	46,3	45,3	43,6	41,0	37,4	32,8	27,4	21,5	
300-400/2000	200	416	416	○	84,2	56,2		55,0	54,7	54,2	53,2	51,7	49,5	46,5	42,6	37,8	32,1	
300-400/2500	250	425	425	●	82,9	59,3		57,9	57,5	56,9	56,0	54,5	52,5	49,7	46,1	41,6	36,0	29,4
300-450/1600	160	404	404	○	86,6	52,5	53,1	52,5	51,4	49,8	47,6	44,8	41,5	37,5	32,9			
300-450/2000	200	430	430	○	88,0	60,7		60,2	59,4	58,1	56,3	53,8	50,7	46,9	42,3	36,9		
300-450/2500	250	456	456	○	88,1	69,1		69,0	68,0	66,7	65,0	62,9	60,3	57,0	53,1	48,1		
300-450/3150	315	470	470	●	89,0	74,9		73,5	72,8	71,6	70,0	67,9	65,4	62,4	58,8	54,5	49,3	

Hydraulic performances in compliance with ISO 9906:2012 - Grade 3B (ex ISO 9906:1999 - Annex A)

Nsc-200-300_4p50-en_c_th

(1) STD = Cast iron/Stainless steel - B = Bronze (2) ● = Full impeller diameter - ○ = Trimmed impeller diameter (3) Hydraulic efficiency of pump.

e-NSC SERIES

OPERATING CHARACTERISTICS AT 50 Hz, 4 POLES

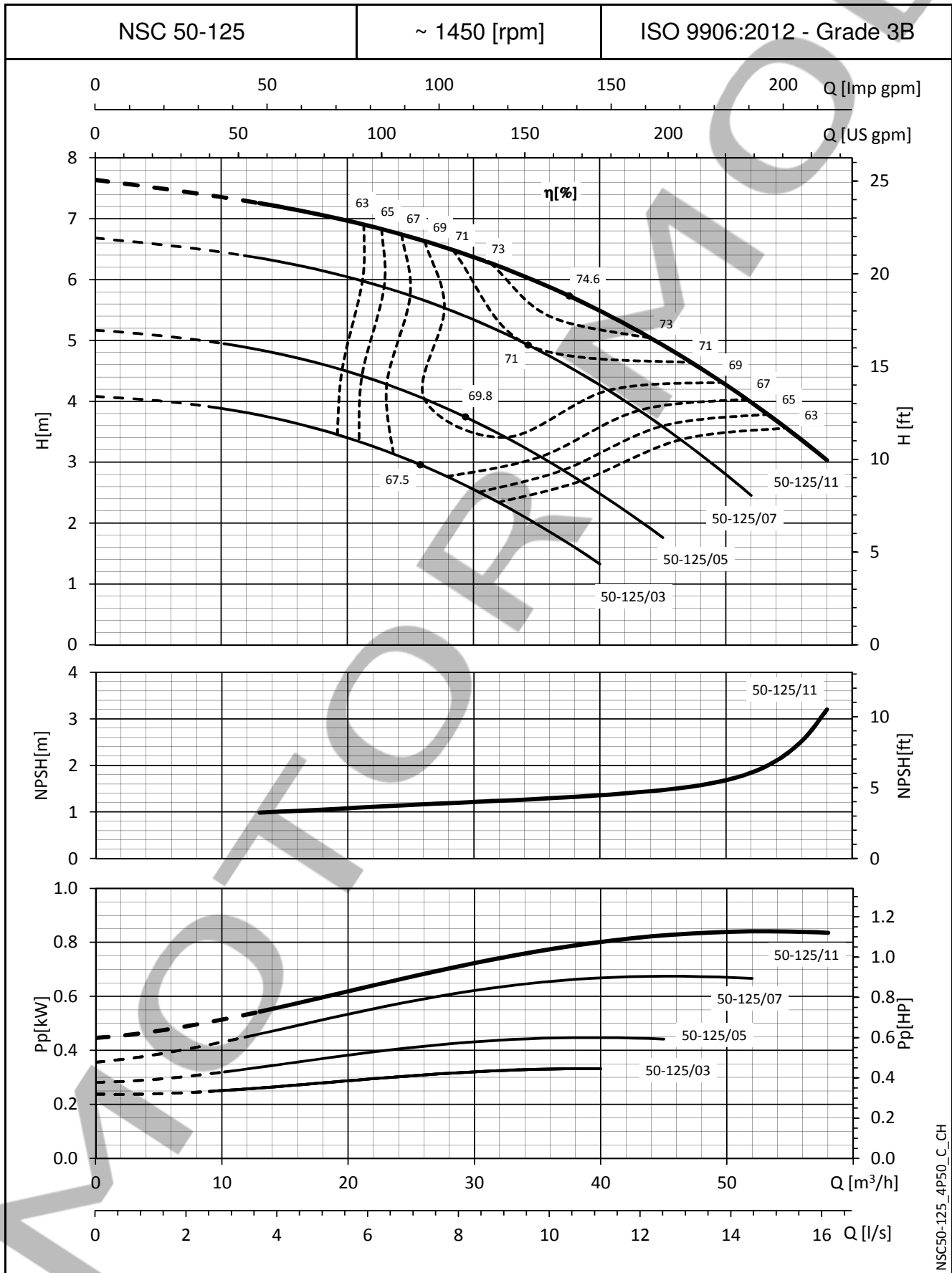

NSC50-125_4P50_C_CH

The NPSH values are laboratory values; for practical use we suggest increasing these values by 0,5 m.
 These performances are valid for liquids with density $\rho = 1,0 \text{ Kg/dm}^3$ and kinematic viscosity $\nu = 1 \text{ mm}^2/\text{sec}$.

e-NSC SERIES

OPERATING CHARACTERISTICS AT 50 Hz, 4 POLES

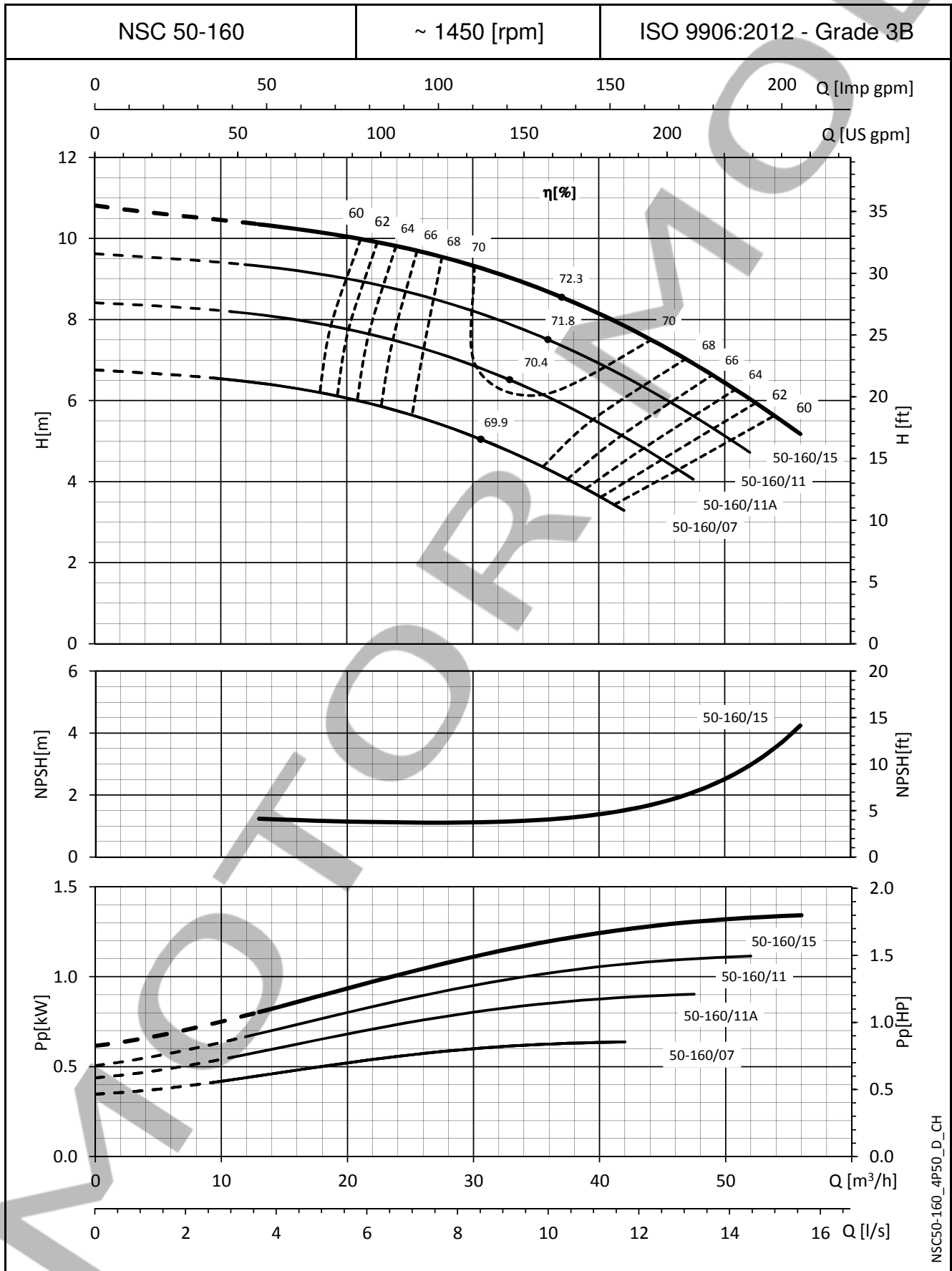

NSC50-160_4P50_D_CH

The NPSH values are laboratory values; for practical use we suggest increasing these values by 0,5 m.
 These performances are valid for liquids with density $\rho = 1,0 \text{ Kg/dm}^3$ and kinematic viscosity $\nu = 1 \text{ mm}^2/\text{sec}$.

e-NSC SERIES

OPERATING CHARACTERISTICS AT 50 Hz, 4 POLES

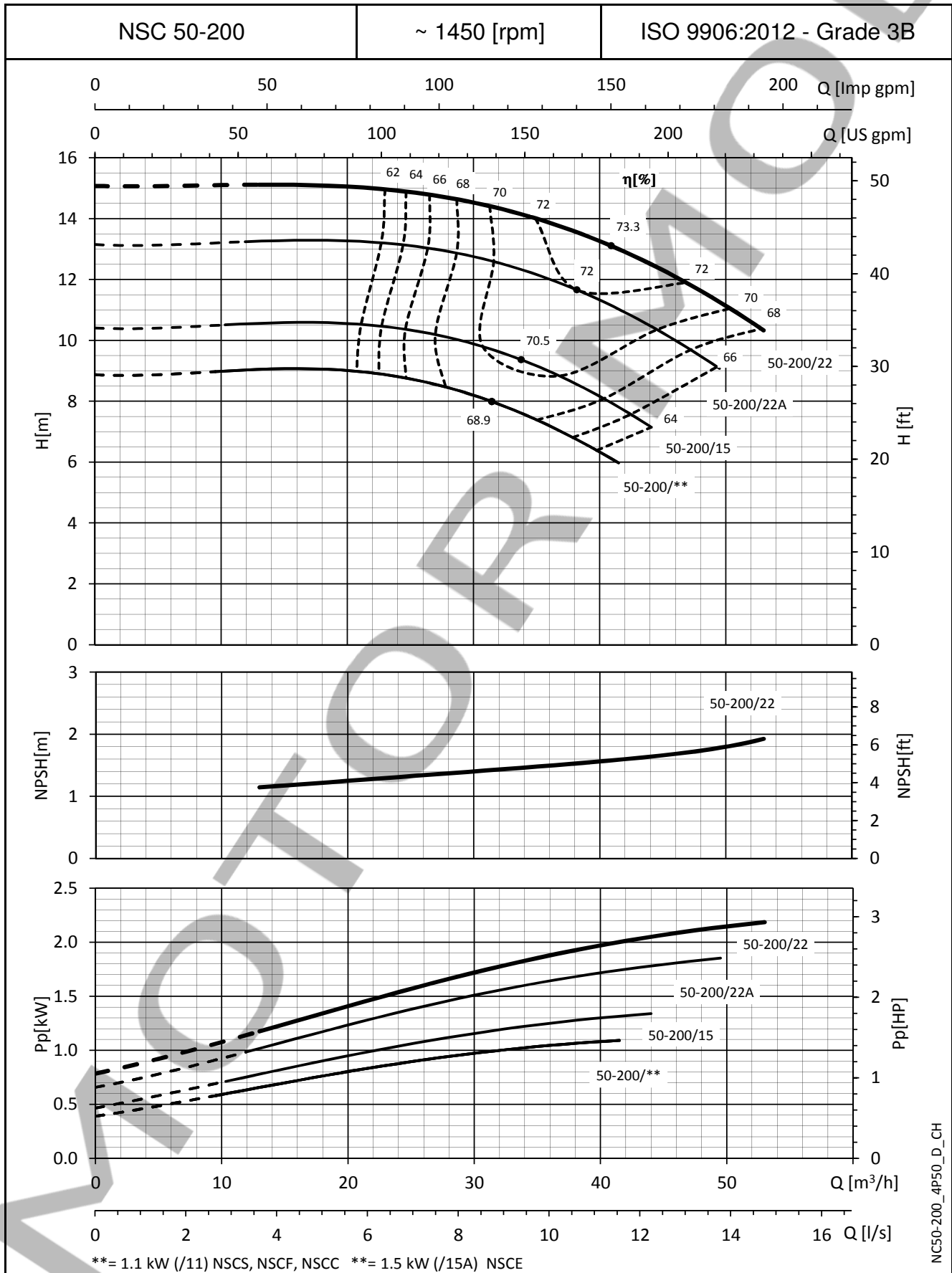

NC50-200_4P50_D_CH

The NPSH values are laboratory values; for practical use we suggest increasing these values by 0,5 m.
 These performances are valid for liquids with density $\rho = 1,0 \text{ Kg/dm}^3$ and kinematic viscosity $\nu = 1 \text{ mm}^2/\text{sec}$.

e-NSC SERIES

OPERATING CHARACTERISTICS AT 50 Hz, 4 POLES

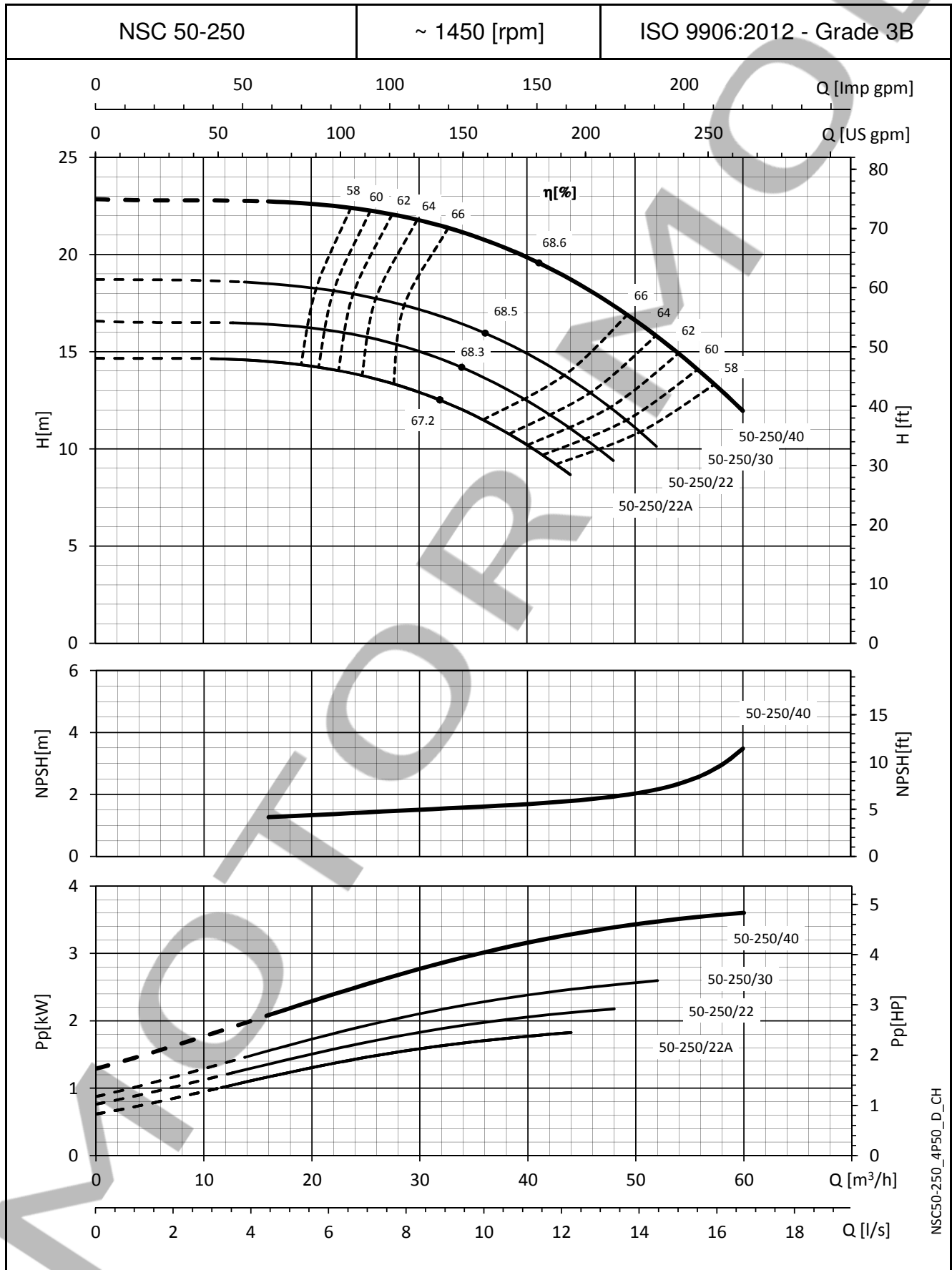

NSC50-250_4P50_D_CH

The NPSH values are laboratory values; for practical use we suggest increasing these values by 0,5 m.
 These performances are valid for liquids with density $\rho = 1,0 \text{ Kg/dm}^3$ and kinematic viscosity $\nu = 1 \text{ mm}^2/\text{sec}$.

e-NSC SERIES

OPERATING CHARACTERISTICS AT 50 Hz, 4 POLES

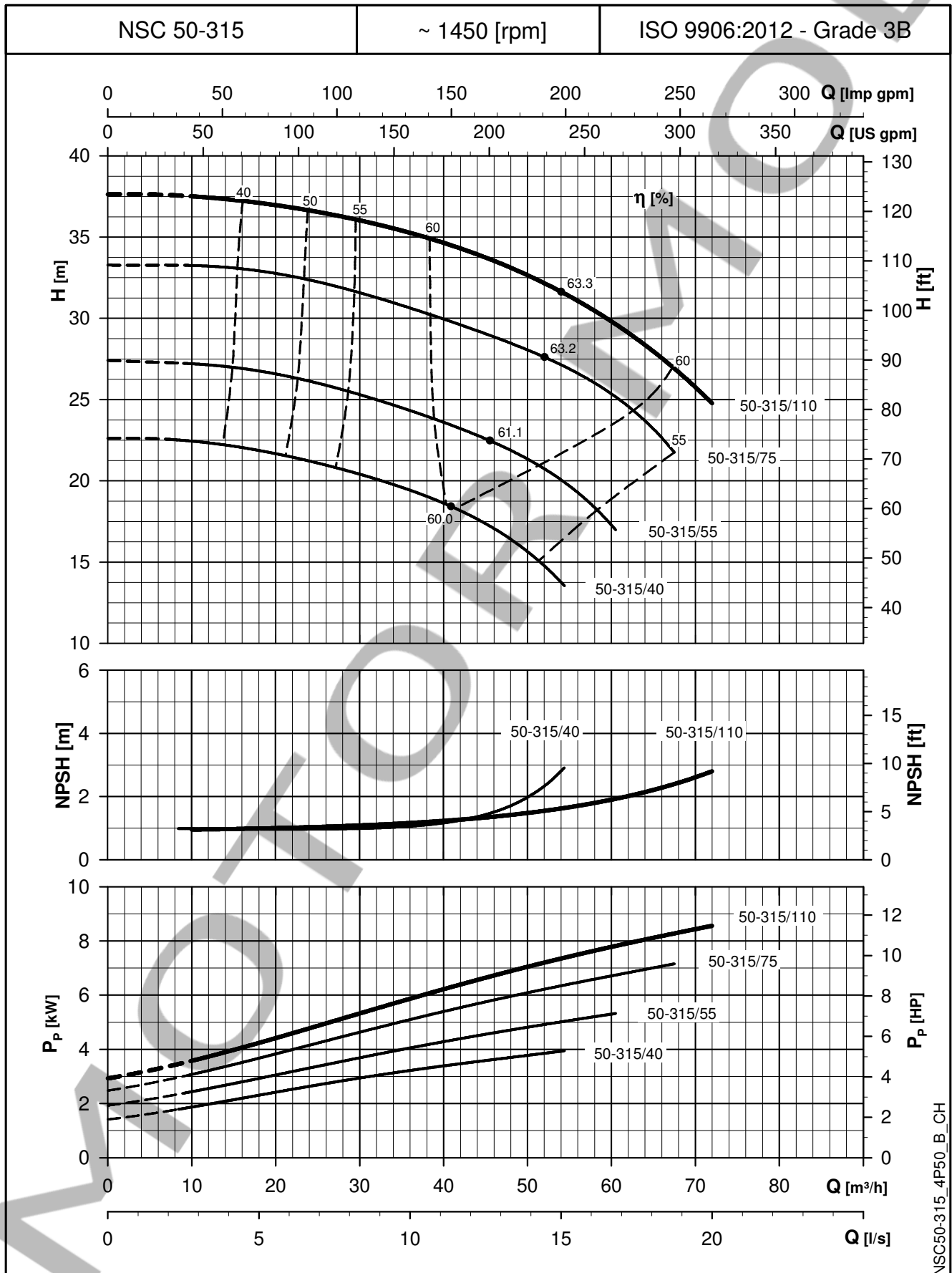

NSC50-315_4P50_B_CH

The NPSH values are laboratory values; for practical use we suggest increasing these values by 0,5 m.
 These performances are valid for liquids with density $\rho = 1,0 \text{ Kg/dm}^3$ and kinematic viscosity $\nu = 1 \text{ mm}^2/\text{sec}$.

NSCS 32, 40, 50 SERIES
DIMENSIONS AND WEIGHTS AT 50 Hz, 4 POLES

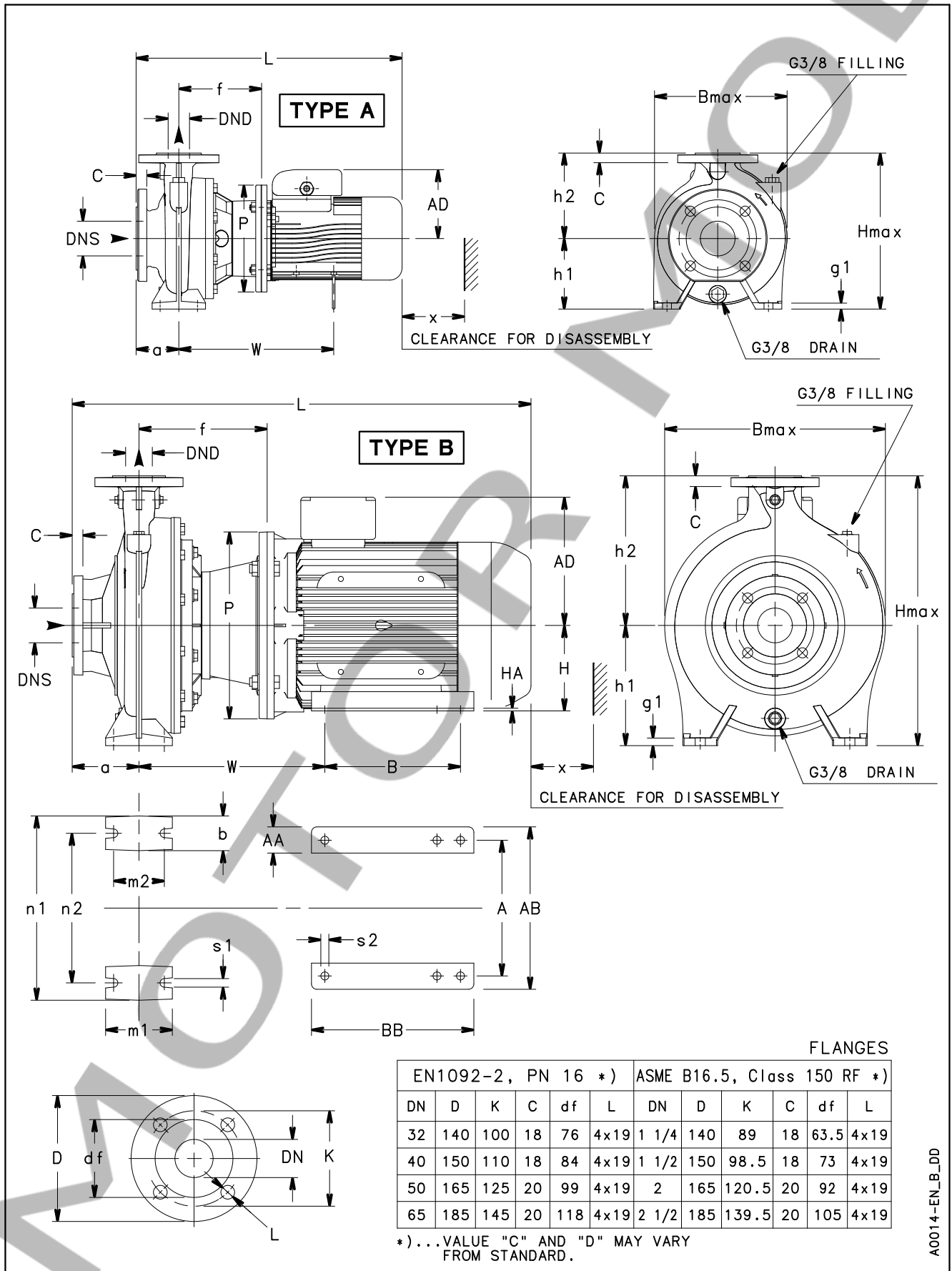

NSCS 32, 40, 50 SERIES DIMENSIONS AND WEIGHTS AT 50 Hz, 4 POLES

PUMP TYPE NSCS..4	TYPE	DIMENSIONS (mm)																								WEIGHT kg					
		DNS	DND	a	b	f	g1	h1	h2	m1	m2	n1	n2	P	s1	W	A	AA	AB	AD	B	BB	H	HA	s2		B max	H max	L	x	
32-160/05A/S	A	50	32	80	50	155	14	132	160	100	70	240	190	200	14	290	-	-	-	129	-	-	-	-	-	-	248	292	498	86	32
32-160/05/S	A	50	32	80	50	155	14	132	160	100	70	240	190	200	14	290	-	-	-	129	-	-	-	-	-	-	248	292	498	86	32
32-200/05A/S	A	50	32	80	50	155	14	160	180	100	70	240	190	200	14	290	-	-	-	129	-	-	-	-	-	-	286	340	498	86	42
32-200/05/S	A	50	32	80	50	155	14	160	180	100	70	240	190	200	14	290	-	-	-	129	-	-	-	-	-	-	286	340	498	86	42
32-200/07/X	A	50	32	80	50	155	14	160	180	100	70	240	190	200	14	-	-	-	-	128	-	-	-	-	-	-	286	340	466	86	43
32-200/11/P	A	50	32	80	50	155	14	160	180	100	70	240	190	200	14	300	-	-	-	134	-	-	-	-	-	-	286	340	533	86	50
32-250/11A/P	A	50	32	100	65	155	21	180	225	125	95	320	250	200	14	245	-	-	-	134	-	-	-	-	-	-	334	405	553	95	48
32-250/11/P	A	50	32	100	65	155	21	180	225	125	95	320	250	200	14	245	-	-	-	134	-	-	-	-	-	-	334	405	553	95	48
32-250/15/P	A	50	32	100	65	155	21	180	225	125	95	320	250	200	14	245	-	-	-	134	-	-	-	-	-	-	334	405	553	95	51
32-250/22/P	A	50	32	100	65	165	21	180	225	125	95	320	250	250	14	285	-	-	-	168	-	-	-	-	-	-	334	405	587	95	61
40-125/05/S	A	65	40	80	50	155	14	112	140	100	70	210	160	200	14	290	-	-	-	129	-	-	-	-	-	-	237	252	498	96	32
40-160/05/S	A	65	40	80	50	155	14	132	160	100	70	240	190	200	14	290	-	-	-	129	-	-	-	-	-	-	250	292	498	92	34
40-160/07/X	A	65	40	80	50	155	14	132	160	100	70	240	190	200	14	-	-	-	-	128	-	-	-	-	-	-	250	292	466	92	38
40-160/11/P	A	65	40	80	50	155	14	132	160	100	70	240	190	200	14	300	-	-	-	134	-	-	-	-	-	-	250	292	533	92	44
40-200/07/X	A	65	40	100	50	155	14	160	180	100	70	265	212	200	14	-	-	-	-	128	-	-	-	-	-	-	290	340	486	90	43
40-200/11/P	A	65	40	100	50	155	14	160	180	100	70	265	212	200	14	300	-	-	-	134	-	-	-	-	-	-	290	340	553	90	49
40-200/15A/P	A	65	40	100	50	155	14	160	180	100	70	265	212	200	14	300	-	-	-	134	-	-	-	-	-	-	290	340	553	90	49
40-200/15/P	A	65	40	100	50	155	14	160	180	100	70	265	212	200	14	300	-	-	-	134	-	-	-	-	-	-	290	340	553	90	52
40-250/11/P	A	65	40	100	65	155	16	180	225	125	95	320	250	200	14	300	-	-	-	134	-	-	-	-	-	-	338	405	553	104	58
40-250/15/P	A	65	40	100	65	155	16	180	225	125	95	320	250	200	14	300	-	-	-	134	-	-	-	-	-	-	338	405	553	104	63
40-250/22A/P	A	65	40	100	65	165	16	180	225	125	95	320	250	250	14	350	-	-	-	168	-	-	-	-	-	-	338	405	587	104	71
40-250/22/P	A	65	40	100	65	165	16	180	225	125	95	320	250	250	14	350	-	-	-	168	-	-	-	-	-	-	338	405	587	104	71
40-250/30/P	A	65	40	100	65	165	16	180	225	125	95	320	250	250	14	350	-	-	-	168	-	-	-	-	-	-	338	405	618	104	75
50-125/05/S	A	65	50	100	50	157	14	132	160	100	70	240	190	200	14	292	-	-	-	129	-	-	-	-	-	-	255	292	520	107	35
50-125/07/X	A	65	50	100	50	157	14	132	160	100	70	240	190	200	14	-	-	-	-	128	-	-	-	-	-	-	255	292	488	107	39
50-125/11/P	A	65	50	100	50	157	14	132	160	100	70	240	190	200	14	302	-	-	-	134	-	-	-	-	-	-	255	292	555	107	45
50-160/07/X	A	65	50	100	50	155	14	160	180	100	70	265	212	200	14	-	-	-	-	128	-	-	-	-	-	-	289	340	486	103	46
50-160/11A/P	A	65	50	100	50	155	14	160	180	100	70	265	212	200	14	300	-	-	-	134	-	-	-	-	-	-	289	340	553	103	52
50-160/11/P	A	65	50	100	50	155	14	160	180	100	70	265	212	200	14	300	-	-	-	134	-	-	-	-	-	-	289	340	553	103	52
50-160/15/P	A	65	50	100	50	155	14	160	180	100	70	265	212	200	14	300	-	-	-	134	-	-	-	-	-	-	289	340	553	103	55
50-200/11/P	A	65	50	100	50	155	14	160	200	100	70	265	212	200	14	247	-	-	-	134	-	-	-	-	-	-	305	360	553	98	52
50-200/15/P	A	65	50	100	50	155	14	160	200	100	70	265	212	200	14	247	-	-	-	134	-	-	-	-	-	-	305	360	553	98	55
50-200/22A/P	A	65	50	100	50	165	14	160	200	100	70	265	212	250	14	287	-	-	-	168	-	-	-	-	-	-	305	360	587	98	65
50-200/22/P	A	65	50	100	50	165	14	160	200	100	70	265	212	250	14	287	-	-	-	168	-	-	-	-	-	-	305	360	587	98	65
50-250/22A/P	A	65	50	100	65	165	16	180	225	125	95	320	250	250	14	285	-	-	-	168	-	-	-	-	-	-	352	405	587	110	72
50-250/22/P	A	65	50	100	65	165	16	180	225	125	95	320	250	250	14	285	-	-	-	168	-	-	-	-	-	-	358	405	587	110	72
50-250/30/P	A	65	50	100	65	165	16	180	225	125	95	320	250	250	14	285	-	-	-	168	-	-	-	-	-	-	358	405	618	110	76
50-250/40/P	A	65	50	100	65	165	16	180	225	125	95	320	250	250	14	410	-	-	-	168	-	-	-	-	-	-	358	405	647	110	95
50-315/40/P	A	65	50	125	65	183	14	225	280	125	95	345	280	250	15	428	-	-	-	168	-	-	-	-	-	-	413	505	706	140	136
50-315/55/P	A	65	50	125	65	210	14	225	280	125	95	345	280	300	15	452	-	-	-	191	-	-	-	-	-	-	413	505	740	140	141
50-315/75/P	A	65	50	125	65	210	14	225	280	125	95	345	280	300	15	452	-	-	-	191	-	-	-	-	-	-	413	505	740	140	146
50-315/110/P	B	65	50	125	65	240	14	225	280	125	95	345	280	350	15	348	254	49	304	240	210	304	160	5	15	413	505	859	140	210	

For shims and supports see accessories section.

ns-cs-32-40-50-4p50-en_e_td

NOTE: Pumps with flanges according to EN 1092-2 as standard; available ASME B16.5 version on request.