

50 Hz



e-NSC Series

HORIZONTAL CENTRIFUGAL ELECTRIC PUMPS
EQUIPPED WITH **IE3** MOTORS

ErP 2009/125/EC

e-NSC 32, 40, 50 SERIES HYDRAULIC PERFORMANCE RANGE AT 50 Hz, 4 POLES

PUMP TYPE	P _N kW	Ø Impeller (mm)				Q = DELIVERY													
		STD	B	●	○	η _p %	l/s 0	0,9	1,3	1,8	2,2	2,7	3,1	3,6	4,0	4,5	4,9	5,4	5,8
							m ³ /h 0	3	5	6	8	10	11	13	14	16	18	19	21
H = TOTAL HEAD METRES COLUMN OF WATER																			
32-125/02B	0,25	113	-	○	56,9	3,5	3,5	3,5	3,3	3,1	2,7	2,3							
32-125/02A	0,25	123	-	○	61,1	4,3		4,3	4,2	4,0	3,7	3,3	2,8	2,2					
32-125/02	0,25	133	-	○	63,4	5,3		5,4	5,3	5,1	4,9	4,5	4,1	3,6	2,9				
32-125/03	0,37	145	-	●	64,5	6,7			6,6	6,4	6,2	5,9	5,5	5,1	4,5	3,8	3,1		
32-160/02	0,25	137	-	○	58,5	5,5		5,5	5,4	5,1	4,8	4,3	3,7	3,0					
32-160/03	0,37	150	-	○	62,1	7,0		6,9	6,8	6,6	6,3	5,9	5,3	4,7	3,9				
32-160/05A	0,55	160,5	-	○	63,3	8,4		8,4	8,4	8,2	8,0	7,6	7,1	6,5	5,8	5,0	4,0		
32-160/05	0,55	171	-	●	63,4	9,5			9,5	9,3	9,1	8,8	8,3	7,8	7,1	6,2	5,3	4,2	
32-200/05A	0,55	158	-	○	54,3	7,9		7,9	7,7	7,4	6,7	5,9	4,9						
32-200/05	0,55	171	-	○	56,5	9,5		9,4	9,3	9,0	8,5	7,7	6,8	5,7					
32-200/07	0,75	186	-	○	58,5	11,9		11,9	11,8	11,6	11,3	10,8	10,0	9,1	7,9				
32-200/11	1,1	205	-	●	60,6	15,1			15,0	14,9	14,7	14,4	13,9	13,2	12,2	11,0			
NSC2 32-250/11A	1,10	177	-	○	47,3	18,7		17,0	16,1	14,8	13,3	11,5	9,6						
NSC2 32-250/11	1,1	195	-	●	50,0	23,3		21,6	20,8	19,7	18,2	16,4	14,3	12,0					
32-250/11A	1,1	214	-	○	44,4	14,5			14,1	13,7	13,1	12,2	11,1						
32-250/15B	1,5	214	-	○	44,4	14,5			14,1	13,7	13,1	12,2	11,1						
32-250/11	1,1	226,5	-	○	45,7	16,3			15,9	15,5	15,0	14,2	13,2	11,9					
32-250/15A	1,5	226,5	-	○	45,7	16,3			15,9	15,5	15,0	14,2	13,2	11,9					
32-250/15	1,5	239	-	○	46,1	18,7				17,8	17,3	16,6	15,7	14,5	13,0				
32-250/22	2,2	259	-	●	46,7	22,6				21,9	21,5	20,9	20,2	19,3	18,1	16,6	14,6		

PUMP TYPE	P _N kW	Ø Impeller (mm)				Q = DELIVERY													
		STD	B	●	○	η _p %	l/s 0	1,3	2,1	2,8	3,6	4,3	5,0	5,8	6,5	7,2	8,0	8,7	9,4
							m ³ /h 0	5	7	10	13	15	18	21	23	26	29	31	34
H = TOTAL HEAD METRES COLUMN OF WATER																			
40-125/02A	0,25	105	-	○	66,1	3,6	3,6	3,5	3,4	3,1	2,8	2,4							
40-125/02	0,25	118	-	○	70,5	4,6		4,4	4,3	4,1	3,8	3,4	2,9						
40-125/03	0,37	130	-	○	73,3	5,6		5,5	5,4	5,3	5,0	4,7	4,3	3,8	3,2				
40-125/05	0,55	135	-	●	74,0	6,5			6,3	6,1	5,9	5,6	5,2	4,8	4,3	3,7			
40-160/03	0,37	127	-	○	66,6	5,2		5,3	5,2	5,0	4,6	4,1	3,6						
40-160/05	0,55	139	-	○	69,0	6,6		6,6	6,6	6,4	6,2	5,8	5,3	4,7					
40-160/07	0,75	154	-	○	70,8	8,3		8,4	8,4	8,4	8,2	7,9	7,6	7,1	6,4	5,7			
40-160/11	1,1	165	-	●	71,1	10,1			10,1	10,0	9,9	9,6	9,3	8,9	8,4	7,8	7,0		
40-200/07	0,75	165	-	○	59,5	9,0		8,9	8,8	8,6	8,2	7,5	6,5	5,2					
40-200/11	1,1	179	-	○	60,6	10,9		11,0	11,0	10,9	10,6	10,1	9,3	8,2	6,9				
40-200/15A	1,5	189	-	○	60,9	12,4			12,5	12,4	12,2	11,7	11,1	10,2	9,0	7,4			
40-200/15	1,5	199	-	●	62,8	14,0			14,0	13,9	13,6	13,3	12,8	12,0	11,1	9,8	8,3	6,4	
40-250/11	1,1	199	-	○	57,9	13,5			13,3	12,9	12,4	11,6	10,6						
40-250/15A	1,5	199	-	○	57,9	13,5			13,3	12,9	12,4	11,6	10,6						
40-250/15	1,5	210	-	○	58,8	15,1			14,9	14,7	14,3	13,6	12,7	11,6					
40-250/22A	1,5	228	-	○	59,1	18,0			18,0	17,8	17,5	17,1	16,4	15,5	14,3				
40-250/22	2,2	243	-	○	60,4	20,6				20,5	20,3	19,9	19,4	18,6	17,6	16,4			
40-250/30	3	257,5	-	●	63,9	24,4				24,1	23,9	23,6	23,1	22,5	21,6	20,6	19,2		

PUMP TYPE	P _N kW	Ø Impeller (mm)				Q = DELIVERY													
		STD	B	●	○	η _p %	l/s 0	2,3	3,9	5,5	7,2	8,8	10,4	12,0	13,6	15,2	16,8	18,4	20,0
							m ³ /h 0	8	14	20	26	32	37	43	49	55	60	66	72
H = TOTAL HEAD METRES COLUMN OF WATER																			
50-125/03	0,37	118	-	○	67,5	4,1		3,7	3,4	3,0	2,4	1,7							
50-125/05	0,55	130	-	○	69,8	5,2		4,8	4,5	4,1	3,5	2,8	2,0						
50-125/07	0,75	144	-	○	71,0	6,7		6,3	6,0	5,7	5,2	4,6	3,9	3,0					
50-125/11	1,1	148	-	●	74,6	7,6		7,2	7,0	6,7	6,3	5,8	5,2	4,4	3,6				
50-160/07	0,75	144	-	○	69,9	6,8		6,4	6,1	5,6	4,9	4,1							
50-160/11A	1,1	159	-	○	70,4	8,4		8,1	7,8	7,3	6,7	5,9	4,9						
50-160/11	1,1	170	-	○	71,8	9,6		9,3	9,0	8,6	8,0	7,3	6,4	5,4					
50-160/15	1,5	176	-	●	72,3	10,8		10,3	10,0	9,7	9,2	8,5	7,7	6,7	5,5				
50-200/11	1,1	168	-	○	68,9	8,9		9,1	9,0	8,7	8,0	6,9							
50-200/15A	1,5	168	-	○	68,9	8,9		9,1	9,0	8,7	8,0	6,9							
50-200/15	1,5	179	-	○	70,5	10,4		10,6	10,6	10,3	9,7	8,7	7,4						
50-200/22A	2,2	197	-	○	72,0	13,1		13,3	13,3	13,1	12,6	11,8	10,7	9,2					
50-200/22	2,2	209	-	●	73,3	15,1		15,1	15,1	14,8	14,4	13,7	12,7	11,4					
50-250/22A	2,2	208	-	○	67,2	14,7		14,6	14,3	13,6	12,6	11,1	9,0						
50-250/22	2,2	220	-	○	68,3	16,6		16,5	16,2	15,7	14,7	13,3	11,4						
50-250/30	3	232	-	○	68,5	18,7		18,6	18,3	17,8	16,9	15,7	13,9	11,6					
50-250/40	4	256	-	●	68,6	22,8			22,6	22,2	21,6	20,5	19,0	17,1	14,6				
50-315/40	4	265	-	○	60,0	22,6	22,5	22,2	21,7	21,0	20,2	19,2	17,9	16,1					
50-315/55	5,5	278	-	○	61,1	27,4		27,0	26,6	25,9	25,1	24,1	23,0	21,7	19,8	17,0			
50-315/75	7,5	304	-	○	63,2	33,3		33,1	32,8	32,2	31,4	30,4	29,4	28,3	27,0	25,2	22,5		
50-315/110	11	322	-	●	63,3	37,6		37,3	37,0	36,5	35,9	35,1	34,1	32,9	31,5	29,7	27,5	24,8	

Hydraulic performances in compliance with ISO 9906:2012 - Grade 3B (ex ISO 9906:1999 - Annex A)

Nsc-32-40-50_4p50-en_d_th

(1) STD = Cast iron/Stainless steel - B = Bronze (2) ● = Full impeller diameter - ○ = Trimmed impeller diameter (3) Hydraulic efficiency of pump.

e-NSC SERIES

OPERATING CHARACTERISTICS AT 50 Hz, 4 POLES

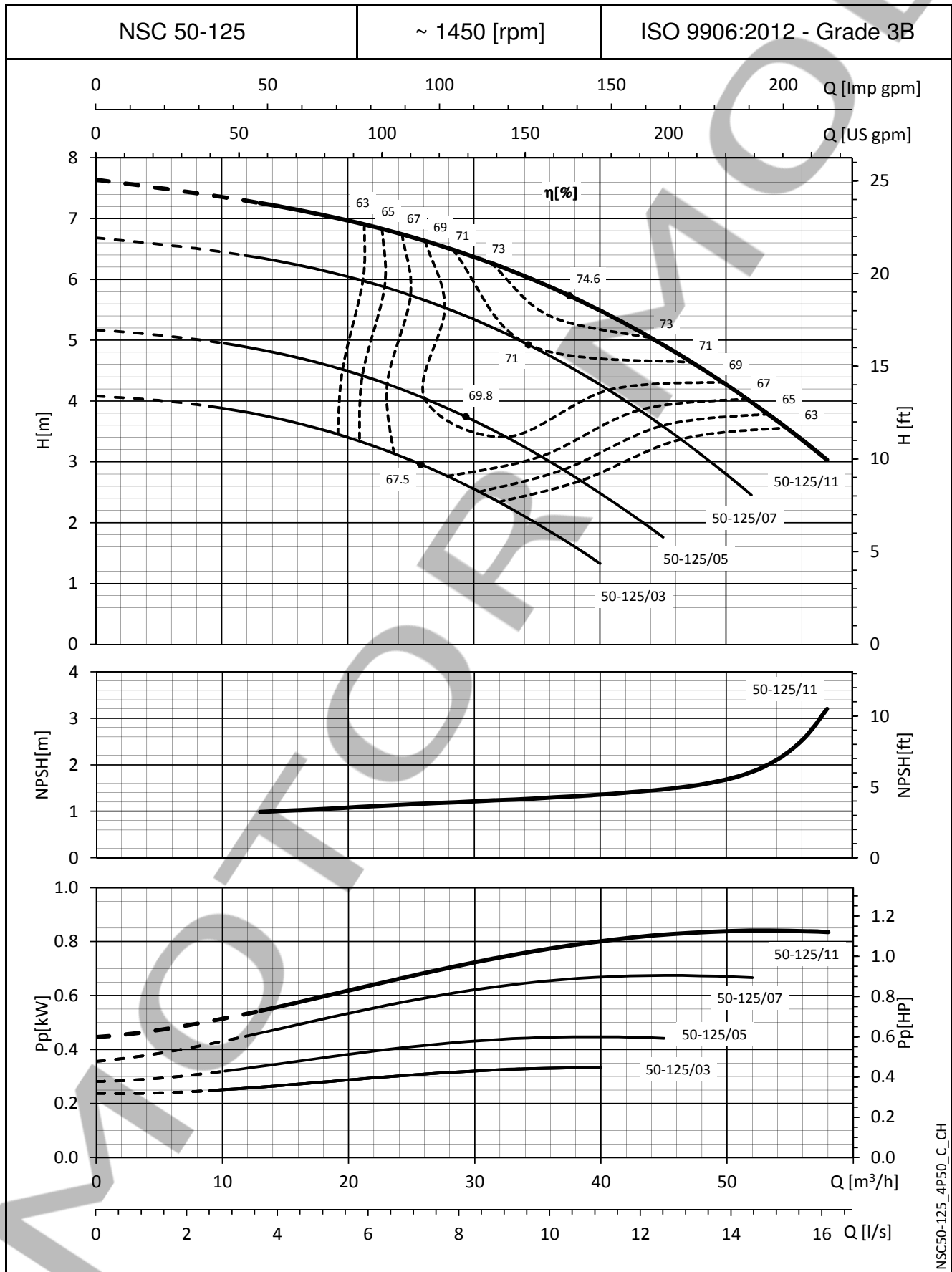

NSC50-125_4P50_C_CH

The NPSH values are laboratory values; for practical use we suggest increasing these values by 0,5 m.
 These performances are valid for liquids with density $\rho = 1,0 \text{ Kg/dm}^3$ and kinematic viscosity $\nu = 1 \text{ mm}^2/\text{sec}$.

e-NSC SERIES

OPERATING CHARACTERISTICS AT 50 Hz, 4 POLES

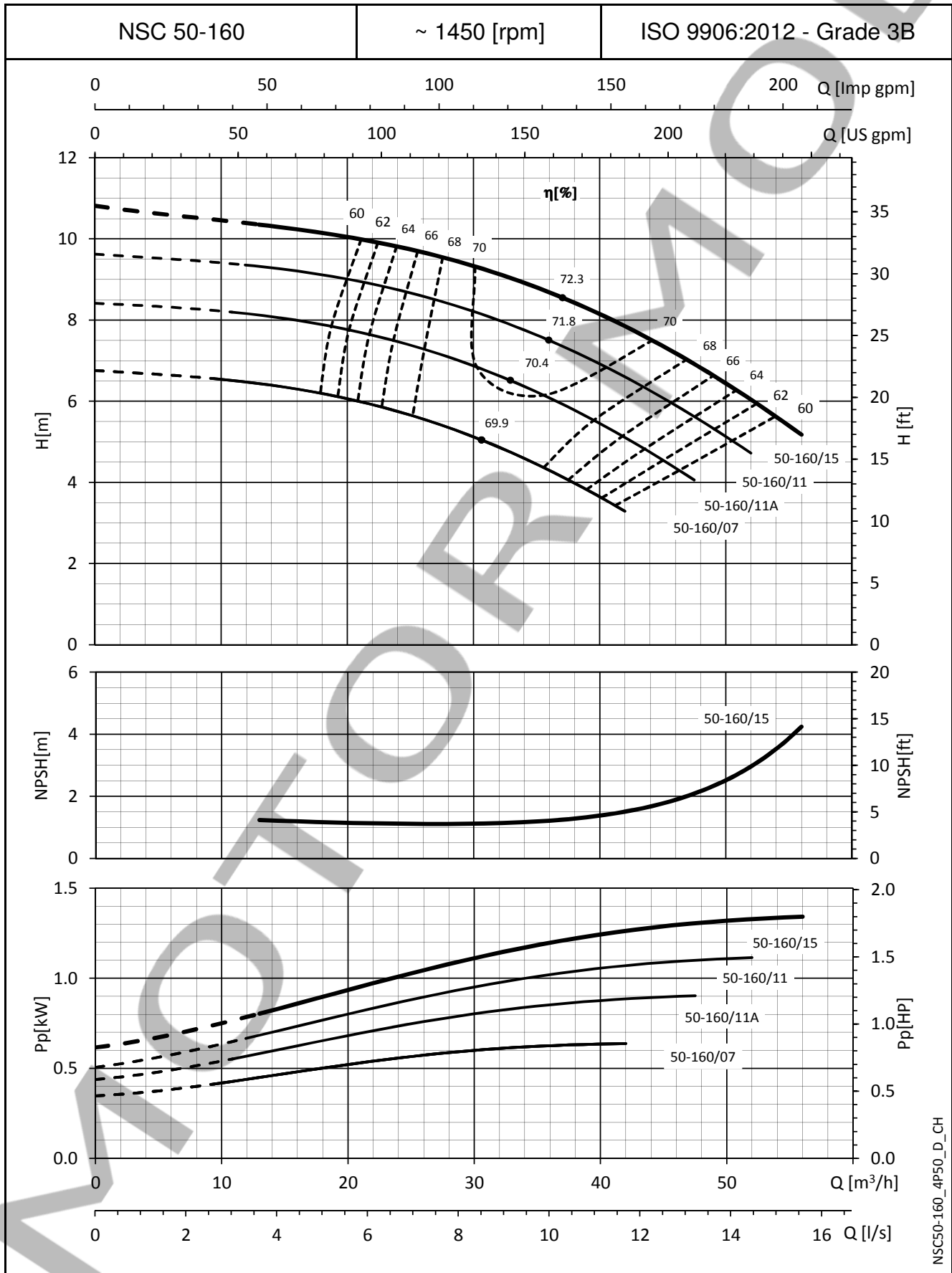

NSC50-160_4P50_D_CH

The NPSH values are laboratory values; for practical use we suggest increasing these values by 0,5 m.
 These performances are valid for liquids with density $\rho = 1,0 \text{ Kg/dm}^3$ and kinematic viscosity $\nu = 1 \text{ mm}^2/\text{sec}$.

e-NSC SERIES

OPERATING CHARACTERISTICS AT 50 Hz, 4 POLES

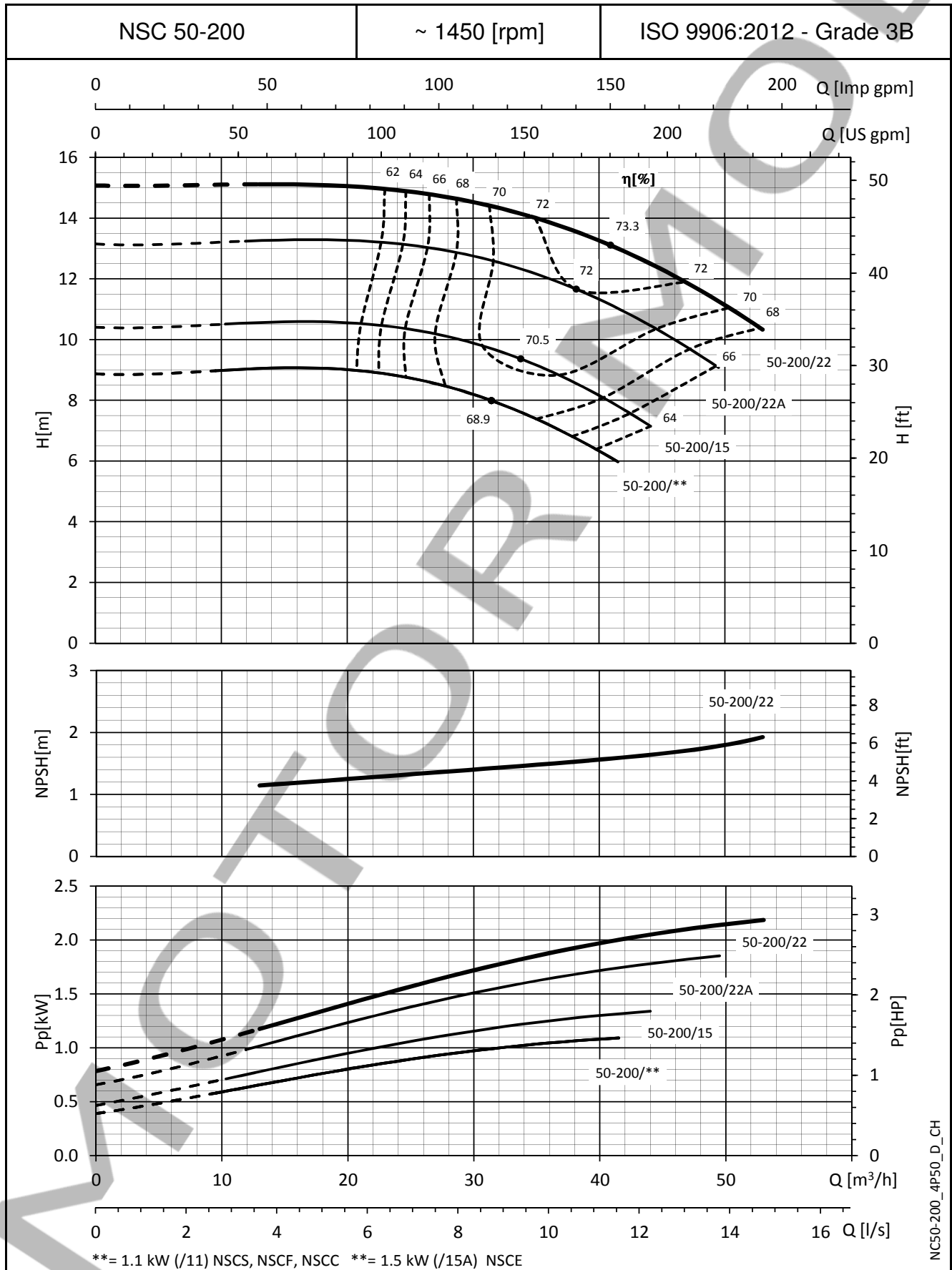

The NPSH values are laboratory values; for practical use we suggest increasing these values by 0,5 m.
 These performances are valid for liquids with density $\rho = 1,0 \text{ Kg/dm}^3$ and kinematic viscosity $\nu = 1 \text{ mm}^2/\text{sec}$.

e-NSC SERIES

OPERATING CHARACTERISTICS AT 50 Hz, 4 POLES

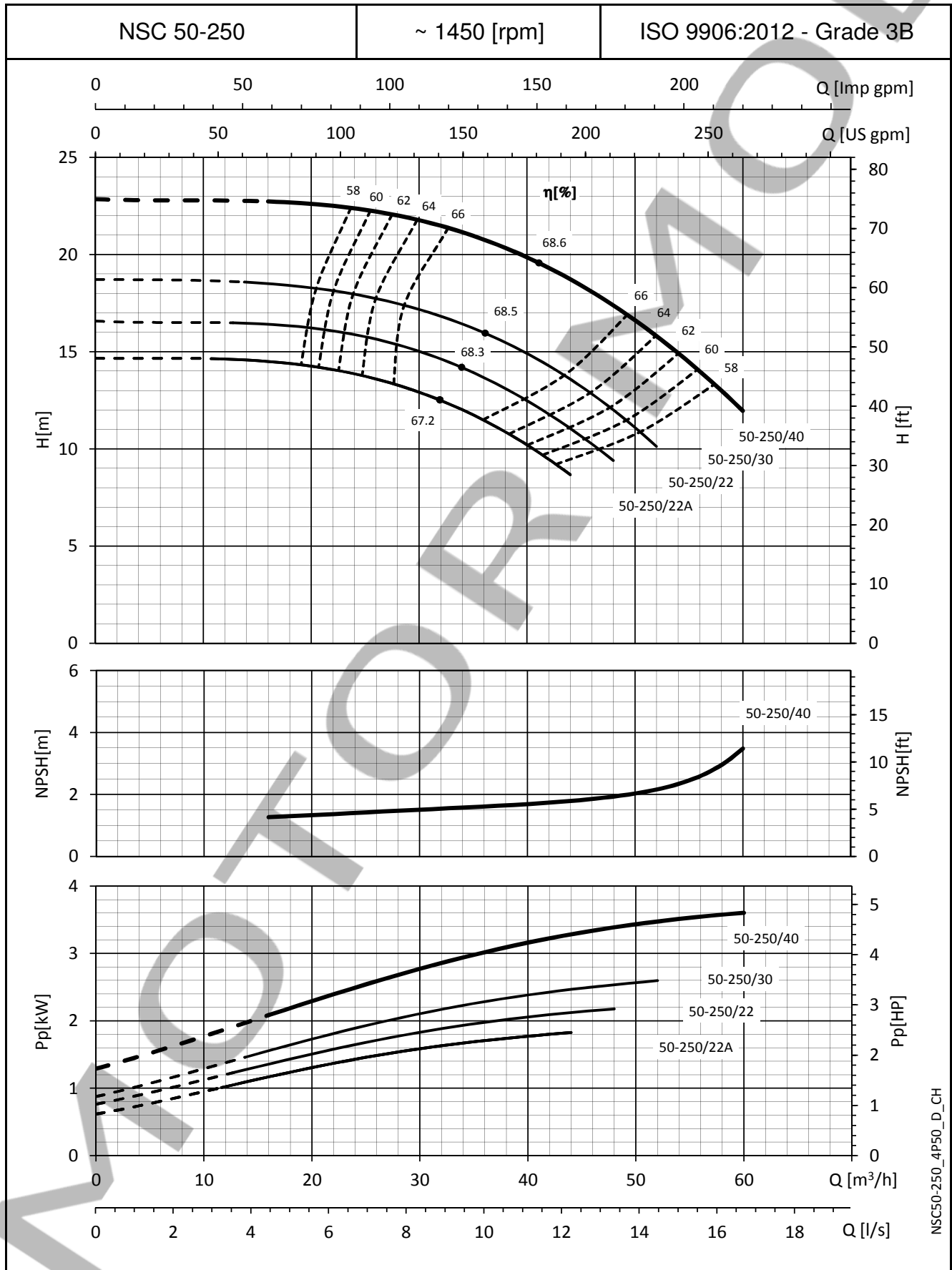

The NPSH values are laboratory values; for practical use we suggest increasing these values by 0,5 m.
 These performances are valid for liquids with density $\rho = 1,0 \text{ Kg/dm}^3$ and kinematic viscosity $\nu = 1 \text{ mm}^2/\text{sec}$.

e-NSC SERIES

OPERATING CHARACTERISTICS AT 50 Hz, 4 POLES

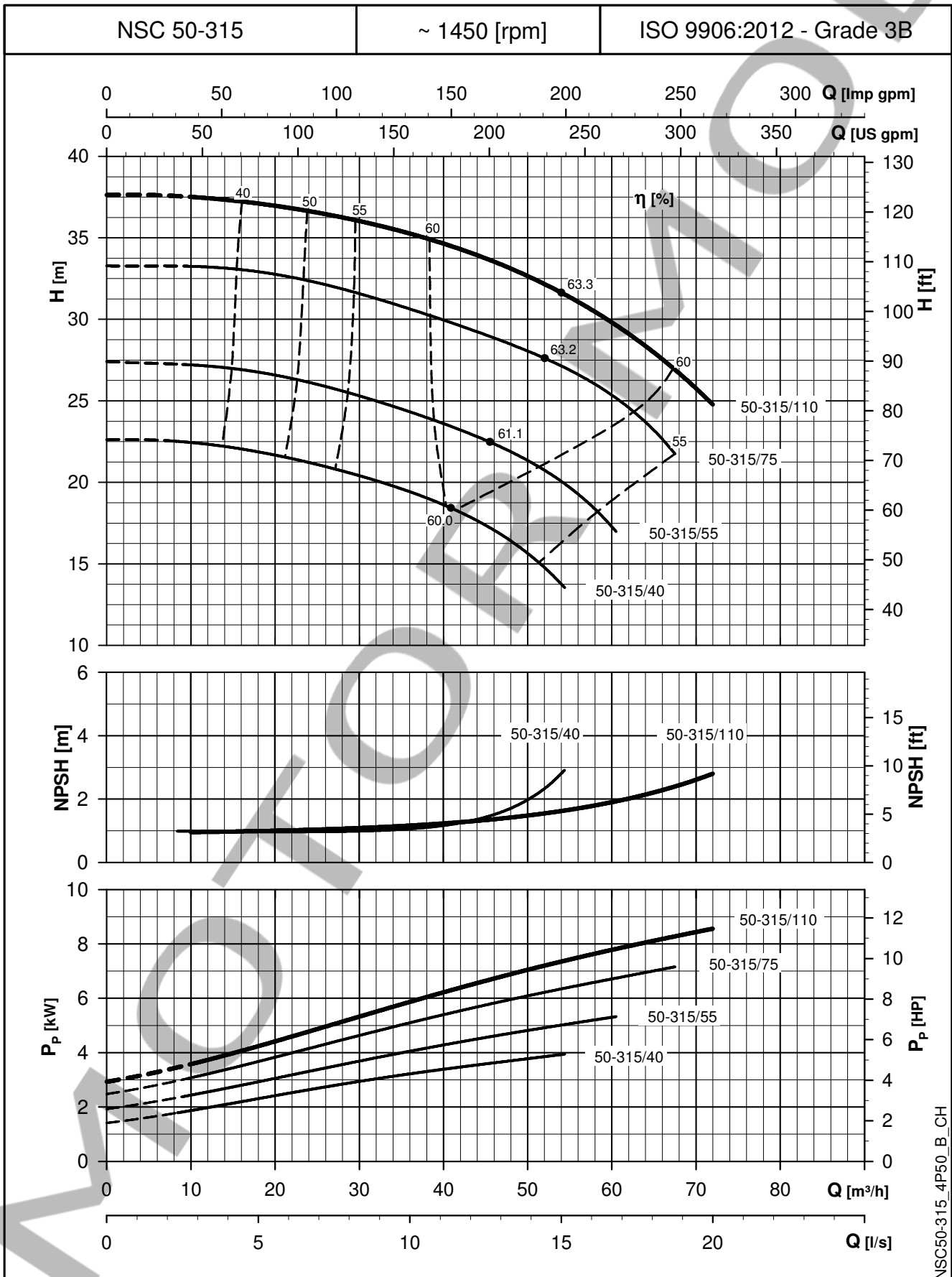

NSC50-315_4P50_B_CH

The NPSH values are laboratory values; for practical use we suggest increasing these values by 0,5 m.
 These performances are valid for liquids with density $\rho = 1,0 \text{ Kg/dm}^3$ and kinematic viscosity $\nu = 1 \text{ mm}^2/\text{sec}$.

NSCF 32 SERIES (MOUNTED ON BASE) DIMENSIONS AND WEIGHTS AT 50 Hz, 4 POLES

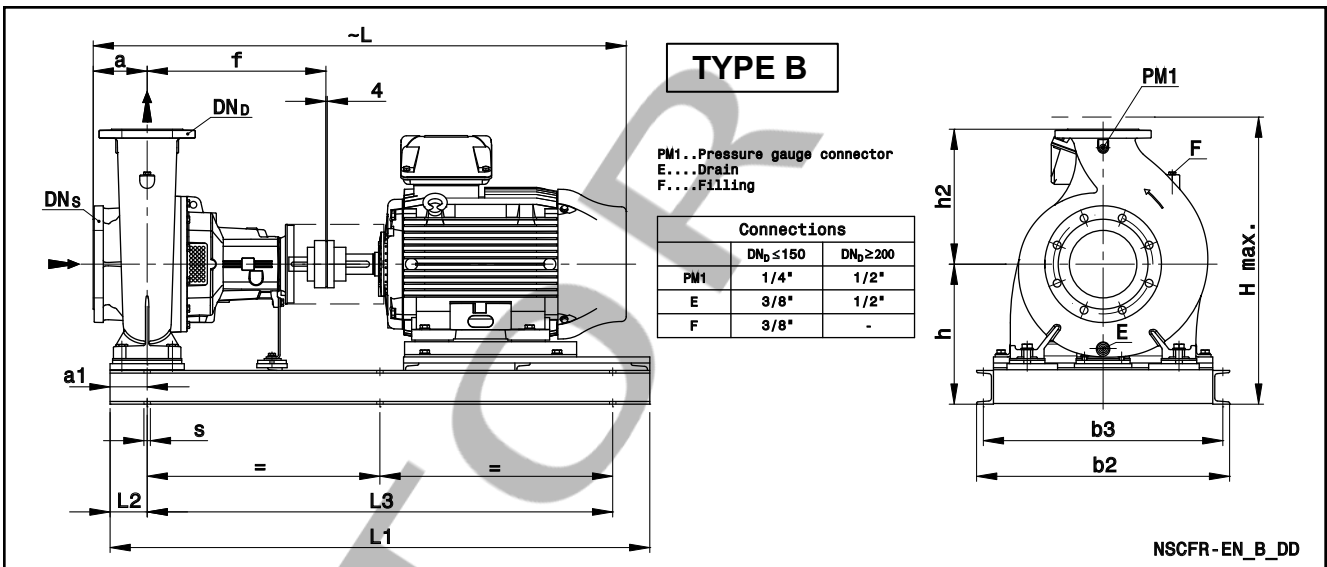
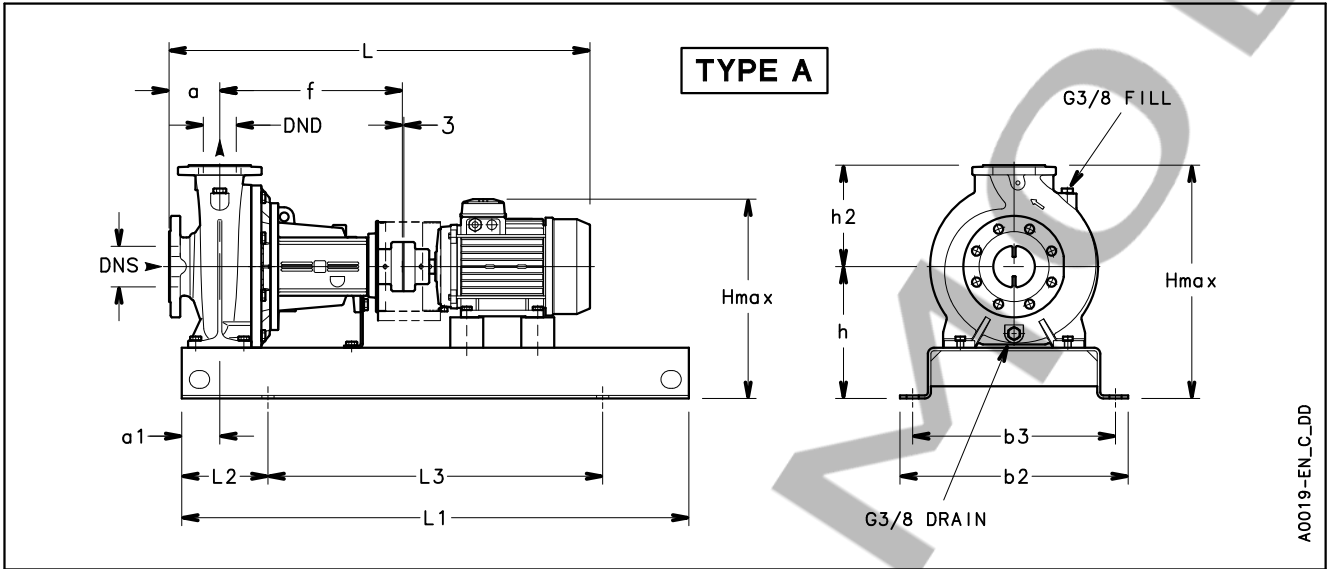

PUMP TYPE NSCF..4	TYPE	DIMENSIONS (mm)														H max	s FOR SCREWS	WEIGHT kg	COUPLING TYPE
		DN _S	DN _D	a	a1	b2	b3	f	h	h2	L	L1	L2	L3					
32-125/02B/S	A	50	32	80	60	360	320	360	212	140	704	800	130	540	352	4xØ19 (M16)	61	B68A	
32-125/02A/S	A	50	32	80	60	360	320	360	212	140	704	800	130	540	352	4xØ19 (M16)	61	B68A	
32-125/02/S	A	50	32	80	60	360	320	360	212	140	704	800	130	540	352	4xØ19 (M16)	61	B68A	
32-125/03/S	A	50	32	80	60	360	320	360	212	140	704	800	130	540	352	4xØ19 (M16)	62	B68A	
32-160/02/S	A	50	32	80	60	360	320	360	232	160	704	800	130	540	392	4xØ19 (M16)	62	B68A	
32-160/03/S	A	50	32	80	60	360	320	360	232	160	704	800	130	540	392	4xØ19 (M16)	63	B68A	
32-160/05A/S	A	50	32	80	60	360	320	360	232	160	746	800	130	540	392	4xØ19 (M16)	66	B68B	
32-160/05/S	A	50	32	80	60	360	320	360	232	160	746	800	130	540	392	4xØ19 (M16)	66	B68B	
32-200/05A/S	A	50	32	80	60	360	320	360	260	180	746	800	130	540	440	4xØ19 (M16)	73	B68B	
32-200/05/S	A	50	32	80	60	360	320	360	260	180	746	800	130	540	440	4xØ19 (M16)	73	B68B	
32-200/07/X	A	50	32	80	60	360	320	360	260	180	714	800	130	540	440	4xØ19 (M16)	76	B68B	
32-200/11/P	A	50	32	80	60	390	350	360	260	180	791	900	150	600	440	4xØ19 (M16)	85	B68C	
32-250/11A/P	A	50	32	100	75	450	400	360	280	225	811	1000	170	660	505	4xØ24 (M20)	112	B68C	
32-250/11/P	A	50	32	100	75	450	400	360	280	225	811	1000	170	660	505	4xØ24 (M20)	112	B68C	
32-250/15/P	A	50	32	100	75	450	400	360	280	225	811	1000	170	660	505	4xØ24 (M20)	117	B68C	
32-250/22/P	A	50	32	100	75	450	400	360	280	225	888	1000	170	660	505	4xØ24 (M20)	127	B80A	

NOTE: Pumps with flanges according to EN 1092-2 as standard.

Nscf32_4p50-en_c_td

Available ASME B16.5 version on request. For flanges dimensions see drawing.

NSCF 40, 50, 65 SERIES (MOUNTED ON BASE) DIMENSIONS AND WEIGHTS AT 50 Hz, 4 POLES

PUMP TYPE NSCF..4	TYPE	DIMENSIONS (mm)													H max	S FOR SCREWS	WEIGHT kg	COUPLING TYPE
		DNS	DND	a	a1	b2	b3	f	h	h2	L	L1	L2	L3				
40-125/02A/S	A	65	40	80	60	360	320	360	212	140	704	800	130	540	352	4xØ19 (M16)	62	B68A
40-125/02/S	A	65	40	80	60	360	320	360	212	140	704	800	130	540	352	4xØ19 (M16)	62	B68A
40-125/03/S	A	65	40	80	60	360	320	360	212	140	704	800	130	540	352	4xØ19 (M16)	63	B68A
40-125/05/S	A	65	40	80	60	360	320	360	212	140	746	800	130	540	352	4xØ19 (M16)	66	B68B
40-160/03/S	A	65	40	80	60	360	320	360	232	160	704	800	130	540	392	4xØ19 (M16)	64	B68A
40-160/05/S	A	65	40	80	60	360	320	360	232	160	746	800	130	540	392	4xØ19 (M16)	67	B68B
40-160/07/X	A	65	40	80	60	360	320	360	232	160	714	800	130	540	392	4xØ19 (M16)	70	B68B
40-160/11/P	A	65	40	80	60	390	350	360	232	160	791	900	150	600	392	4xØ19 (M16)	79	B68C
40-200/07/X	A	65	40	100	60	390	350	360	260	180	734	900	150	600	440	4xØ19 (M16)	81	B68B
40-200/11/P	A	65	40	100	60	390	350	360	260	180	811	900	150	600	440	4xØ19 (M16)	87	B68C
40-200/15A/P	A	65	40	100	60	390	350	360	260	180	811	900	150	600	440	4xØ19 (M16)	92	B68C
40-200/15/P	A	65	40	100	60	390	350	360	260	180	811	900	150	600	440	4xØ19 (M16)	92	B68C
40-250/11/P	A	65	40	100	75	450	400	360	280	225	811	1000	170	660	505	4xØ24 (M20)	113	B68C
40-250/15/P	A	65	40	100	75	450	400	360	280	225	811	1000	170	660	505	4xØ24 (M20)	118	B68C
40-250/22A/P	A	65	40	100	75	450	400	360	280	225	888	1000	170	660	505	4xØ24 (M20)	128	B80A
40-250/22/P	A	65	40	100	75	450	400	360	280	225	888	1000	170	660	505	4xØ24 (M20)	128	B80A
40-250/30/P	A	65	40	100	75	450	400	360	280	225	906	1000	170	660	505	4xØ24 (M20)	133	B80A
50-125/03/S	A	65	50	100	60	360	320	360	232	160	724	800	130	540	392	4xØ19 (M16)	66	B68A
50-125/05/S	A	65	50	100	60	360	320	360	232	160	766	800	130	540	392	4xØ19 (M16)	69	B68B
50-125/07/X	A	65	50	100	60	360	320	360	232	160	734	800	130	540	392	4xØ19 (M16)	72	B68B
50-125/11/P	A	65	50	100	60	390	350	360	232	160	811	900	150	600	392	4xØ19 (M16)	81	B68C
50-160/07/X	A	65	50	100	60	390	350	360	260	180	734	900	150	600	440	4xØ19 (M16)	82	B68B
50-160/11A/P	A	65	50	100	60	390	350	360	260	180	811	900	150	600	440	4xØ19 (M16)	88	B68C
50-160/11/P	A	65	50	100	60	390	350	360	260	180	811	900	150	600	440	4xØ19 (M16)	88	B68C
50-160/15/P	A	65	50	100	60	390	350	360	260	180	811	900	150	600	440	4xØ19 (M16)	93	B68C
50-200/11/P	A	65	50	100	60	390	350	360	260	200	811	900	150	600	460	4xØ19 (M16)	89	B68C
50-200/15/P	A	65	50	100	60	390	350	360	260	200	811	900	150	600	460	4xØ19 (M16)	94	B68C
50-200/22A/P	A	65	50	100	60	390	350	360	260	200	888	900	150	600	460	4xØ19 (M16)	104	B80A
50-200/22/P	A	65	50	100	60	390	350	360	260	200	888	900	150	600	460	4xØ19 (M16)	104	B80A
50-250/22A/P	A	65	50	100	75	450	400	360	280	225	888	1000	170	660	505	4xØ24 (M20)	129	B80A
50-250/22/P	A	65	50	100	75	450	400	360	280	225	888	1000	170	660	505	4xØ24 (M20)	129	B80A
50-250/30/P	A	65	50	100	75	450	400	360	280	225	906	1000	170	660	505	4xØ24 (M20)	134	B80A
50-250/40/P	A	65	50	100	75	450	400	360	280	225	906	1000	170	660	505	4xØ24 (M20)	153	B80A
50-315/40/P	B	65	50	125	110	670	630	470	365	280	1041	1100	110	880	645	6xØ19 (M16)	246,6	B95C
50-315/55/P	B	65	50	125	110	670	630	470	385	280	1084	1100	110	880	665	6xØ19 (M16)	258	B95D
50-315/75/P	B	65	50	125	110	670	630	470	385	280	1084	1100	110	880	665	6xØ19 (M16)	258	B95D
50-315/110/P	B	65	50	125	110	670	630	470	365	280	1198	1330	110	1110	645	6xØ19 (M16)	290,3	B95E
65-125/05/S	A	80	65	100	75	390	350	360	260	180	766	900	150	600	440	4xØ19 (M16)	83	B68B
65-125/07/X	A	80	65	100	75	390	350	360	260	180	734	900	150	600	440	4xØ19 (M16)	86	B68B
65-125/11/P	A	80	65	100	75	390	350	360	260	180	811	900	150	600	440	4xØ19 (M16)	92	B68C
65-125/15/P	A	80	65	100	75	390	350	360	260	180	811	900	150	600	440	4xØ19 (M16)	97	B68C
65-160/11A/P	A	80	65	100	75	450	400	360	260	200	811	1000	170	660	460	4xØ24 (M20)	113	B68C
65-160/11/P	A	80	65	100	75	450	400	360	260	200	811	1000	170	660	460	4xØ24 (M20)	113	B68C
65-160/15/P	A	80	65	100	75	450	400	360	260	200	811	1000	170	660	460	4xØ24 (M20)	118	B68C
65-160/22A/P	A	80	65	100	75	450	400	360	260	200	888	1000	170	660	460	4xØ24 (M20)	128	B80A
65-160/22/P	A	80	65	100	75	450	400	360	260	200	888	1000	170	660	460	4xØ24 (M20)	128	B80A
65-200/15/P	A	80	65	100	75	450	400	360	280	225	811	1000	170	660	505	4xØ24 (M20)	121	B68C
65-200/22A/P	A	80	65	100	75	490	440	360	280	225	888	1120	190	740	505	4xØ24 (M20)	137	B80A
65-200/22/P	A	80	65	100	75	490	440	360	280	225	888	1120	190	740	505	4xØ24 (M20)	137	B80A
65-200/30/P	A	80	65	100	75	490	440	360	280	225	906	1120	190	740	505	4xØ24 (M20)	142	B80A
65-200/40/P	A	80	65	100	75	490	440	360	280	225	906	1120	190	740	505	4xØ24 (M20)	161	B80A
65-250/30/P	A	80	65	100	90	490	440	470	310	250	1016	1120	190	740	560	4xØ24 (M20)	161	B95C
65-250/40/P	A	80	65	100	90	490	440	470	310	250	1016	1120	190	740	560	4xØ24 (M20)	180	B95C
65-250/55A/P	A	80	65	100	90	490	440	470	310	250	1058	1120	190	740	560	4xØ24 (M20)	189	B95D
65-250/55/P	A	80	65	100	90	490	440	470	310	250	1058	1120	190	740	560	4xØ24 (M20)	189	B95D
65-250/75/P	A	80	65	100	90	490	440	470	310	250	1058	1120	190	740	560	4xØ24 (M20)	193	B95D
65-315/55/P	B	80	65	125	110	670	630	470	385	280	1084	1100	110	880	665	6xØ19 (M16)	265,3	B95D
65-315/75/P	B	80	65	125	110	670	630	470	385	280	1084	1100	110	880	665	6xØ19 (M16)	265,3	B95D
65-315/110/P	B	80	65	125	110	670	630	470	365	280	1203	1330	110	1110	645	6xØ19 (M16)	297,5	B95E
65-315/150/P	B	80	65	125	110	670	630	470	365	280	1203	1330	110	1110	645	6xØ19 (M16)	342,4	B110E

NOTE: Pumps with flanges according to EN 1092-2 as standard.

Nscf40-65_4p50-en_d_td

Available ASME B16.5 version on request. For flanges dimensions see drawing.