

50 Hz



e-NSC Series

HORIZONTAL CENTRIFUGAL ELECTRIC PUMPS
EQUIPPED WITH **IE3** MOTORS

ErP 2009/125/EC

Cod. 191002951 Rev. G Ed.07/2017

 **LOWARA**
a xylem brand

e-NSC 200-250-300 SERIES

HYDRAULIC PERFORMANCE RANGE AT 50 Hz, 4 POLES

PUMP TYPE	P _N kW	Ø Impeller (mm)				Q = DELIVERY												
		STD (1)	B (2)	● (3)	η _p %	vs 0	38,1	62,4	86,7	111,0	135,3	159,6	184,0	208,3	232,6	256,9	281,2	305,6
						m ³ /h 0	137	225	312	400	487	575	662	750	837	925	1012	1100
H = TOTAL HEAD METRES COLUMN OF WATER																		
200-250/185	18,5	228	228	○	78,6	15,7	15,3	14,8	13,7	12,2	10,6	8,9	6,8					
200-250/220	22	245	245	○	81,6	18,5		17,2	16,2	14,8	13,1	11,1	8,7					
200-250/300A	30	260	260	○	83,9	21,2		19,7	18,7	17,4	15,8	13,7	11,2	8,4				
200-250/300	30	271	271	●	85,0	23,1		21,5	20,5	19,4	17,9	16,0	13,6	10,8				
200-315/300	30	268	268	○	80,7	22,1	21,7	21,3	20,7	19,6	17,7	14,9	11,3					
200-315/450	37	287	287	○	82,9	25,3		24,6	24,2	23,3	21,7	19,3	15,9	11,8				
200-315/370	45	306	306	○	84,8	29,0		28,3	28,1	27,4	26,1	23,9	20,8	16,8	12,3			
200-315/550	55	328	328	○	86,1	34,1		33,2	32,8	32,1	30,9	28,8	26,0	22,2	17,8			
200-315/750	75	333	333	●	86,3	35,1		34,3	34,0	33,3	32,0	29,9	27,1	23,4	19,1			
200-400/750A	75	328	328	○	83,4	37,2		37,0	36,7	35,7	33,8	31,0	27,0	22,0				
200-400/750	75	342	342	○	83,5	41,0		40,6	40,3	39,4	37,7	35,0	31,3	26,5				
200-400/900	90	362	362	○	84,2	46,5		46,0	45,7	44,9	43,4	41,1	37,7	33,3	27,9			
200-400/1100	110	383	383	○	85,4	52,4		52,2	51,9	51,2	50,0	48,0	45,1	41,2	36,2			
200-400/1320	132	409	409	●	85,5	60,1		59,8	59,6	59,0	57,9	56,1	53,5	50,0	45,4	39,6		
200-500/1320	132	425	425	○	80,5	64,3		64,4	63,7	62,5	60,2	56,4	50,8	43,3	34,2			
200-500/1600	160	450	450	○	81,2	72,8		72,7	72,2	71,0	69,0	65,8	61,2	55,0	46,9			
200-500/2000	200	480	480	○	82,6	83,8		83,6	83,1	82,1	80,3	77,7	74,0	69,1	62,5	53,8		
200-500/2500	250	508	508	○	83,0	94,3		93,8	93,3	92,3	90,7	88,3	85,1	81,0	75,8	69,2	60,7	
200-500/3150	315	523	523	●	83,3	100,3		99,6	99,1	98,1	96,4	94,1	91,0	87,2	82,5	76,6	69,1	59,6

PUMP TYPE	P _N kW	Ø Impeller (mm)				Q = DELIVERY												
		STD (1)	B (2)	● (3)	η _p %	vs 0	61,9	94,2	126,4	158,7	190,9	223,2	255,4	287,7	319,9	352,2	384,4	416,7
						m ³ /h 0	223	339	455	571	687	803	920	1036	1152	1268	1384	1500
H = TOTAL HEAD METRES COLUMN OF WATER																		
250-315/370	37	255	255	○	81,1	19,4	19,2	18,5	17,7	16,7	15,3	13,3	10,4					
250-315/450	45	273	273	○	83,1	22,7		21,8	21,0	20,1	18,9	16,9	13,8	10,0				
250-315/550	55	290	290	○	84,5	26,1		24,8	24,3	23,6	22,6	20,7	18,0	14,5				
250-315/750	75	316	316	●	85,7	31,5		29,9	29,5	29,1	28,4	27,1	25,0	22,1	18,6			
250-400/750	75	325	325	○	82,0	35,4		35,2	34,3	32,5	29,9	26,3	21,8	16,4				
250-400/900	90	344	344	○	82,9	39,8		39,8	39,2	37,9	35,6	32,3	27,9	22,5				
250-400/1100	110	365	365	○	84,0	45,1		45,0	44,8	43,8	42,0	39,1	35,1	30,0	23,9			
250-400/1320	132	386	386	○	85,1	50,8		50,6	50,4	49,7	48,1	45,6	42,0	37,3	31,5			
250-400/1600	160	407	407	○	85,8	56,9		56,4	56,2	55,6	54,2	52,0	48,9	44,7	39,4	33,0		
250-400/2000	200	425	425	●	86,5	62,7		62,0	61,6	60,9	59,6	57,6	54,9	51,2	46,5	40,6		
250-500/1600	160	420	420	○	82,3	61,1		61,6	60,8	59,2	56,4	52,2	46,3	38,1				
250-500/2000	200	448	448	○	84,5	70,3		71,0	70,7	69,6	67,6	64,1	59,0	51,8	42,3			
250-500/2500	250	477	477	○	84,6	80,5		81,0	80,6	79,7	78,2	75,6	71,8	66,3	58,8	48,9		
250-500/3150	315	508	508	○	84,9	92,6		93,3	92,7	91,6	90,0	87,6	84,5	80,3	74,8	67,8	58,9	
250-500/3550	355	523	523	●	85,0	98,3		99,0	98,4	97,3	95,7	93,6	90,6	86,8	81,9	75,7	68,0	58,5

PUMP TYPE	P _N kW	Ø Impeller (mm)				Q = DELIVERY												
		STD (1)	B (2)	● (3)	η _p %	vs 0	92,8	132,3	171,9	211,4	251,0	290,5	330,1	369,6	409,1	448,7	488,2	527,8
						m ³ /h 0	334	476	619	761	903	1046	1188	1331	1473	1615	1758	1900
H = TOTAL HEAD METRES COLUMN OF WATER																		
300-350/750A	75	285	285	○	79,0	24,4		22,4	21,4	20,0	18,3	16,3	13,9	11,3	8,2			
300-350/750	75	315	315	○	82,2	30,5		28,1	26,8	25,3	23,4	21,2	18,7	15,9	12,7	9,1		
300-350/900	90	332	332	○	83,2	34,7		32,0	30,7	29,1	27,3	25,2	22,7	19,9	16,8	13,3		
300-350/1100	110	354	354	●	85,8	39,7		37,1	36,0	34,6	32,9	30,9	28,5	25,8	22,7	19,2	15,4	
300-400/1100	110	346	346	○	88,2	36,2		36,3	35,9	34,9	33,2	30,8	27,6	23,7	19,1			
300-400/1320	132	367	367	○	87,5	41,9		41,4	41,0	40,2	38,8	36,6	33,6	29,7	25,0	19,7		
300-400/1600	160	390	390	○	86,0	48,0		47,2	46,9	46,3	45,3	43,6	41,0	37,4	32,8	27,4	21,5	
300-400/2000	200	416	416	○	84,2	56,2		55,0	54,7	54,2	53,2	51,7	49,5	46,5	42,6	37,8	32,1	
300-400/2500	250	425	425	●	82,9	59,3		57,9	57,5	56,9	56,0	54,5	52,5	49,7	46,1	41,6	36,0	29,4
300-450/1600	160	404	404	○	86,6	52,5	53,1	52,5	51,4	49,8	47,6	44,8	41,5	37,5	32,9			
300-450/2000	200	430	430	○	88,0	60,7		60,2	59,4	58,1	56,3	53,8	50,7	46,9	42,3	36,9		
300-450/2500	250	456	456	○	88,1	69,1		69,0	68,0	66,7	65,0	62,9	60,3	57,0	53,1	48,1		
300-450/3150	315	470	470	●	89,0	74,9		73,5	72,8	71,6	70,0	67,9	65,4	62,4	58,8	54,5	49,3	

Hydraulic performances in compliance with ISO 9906:2012 - Grade 3B (ex ISO 9906:1999 - Annex A)

Nsc-200-300_4p50-en_c_th

(1) STD = Cast iron/Stainless steel - B = Bronze (2) ● = Full impeller diameter - ○ = Trimmed impeller diameter (3) Hydraulic efficiency of pump.

e-NSC SERIES

OPERATING CHARACTERISTICS AT 50 Hz, 4 POLES

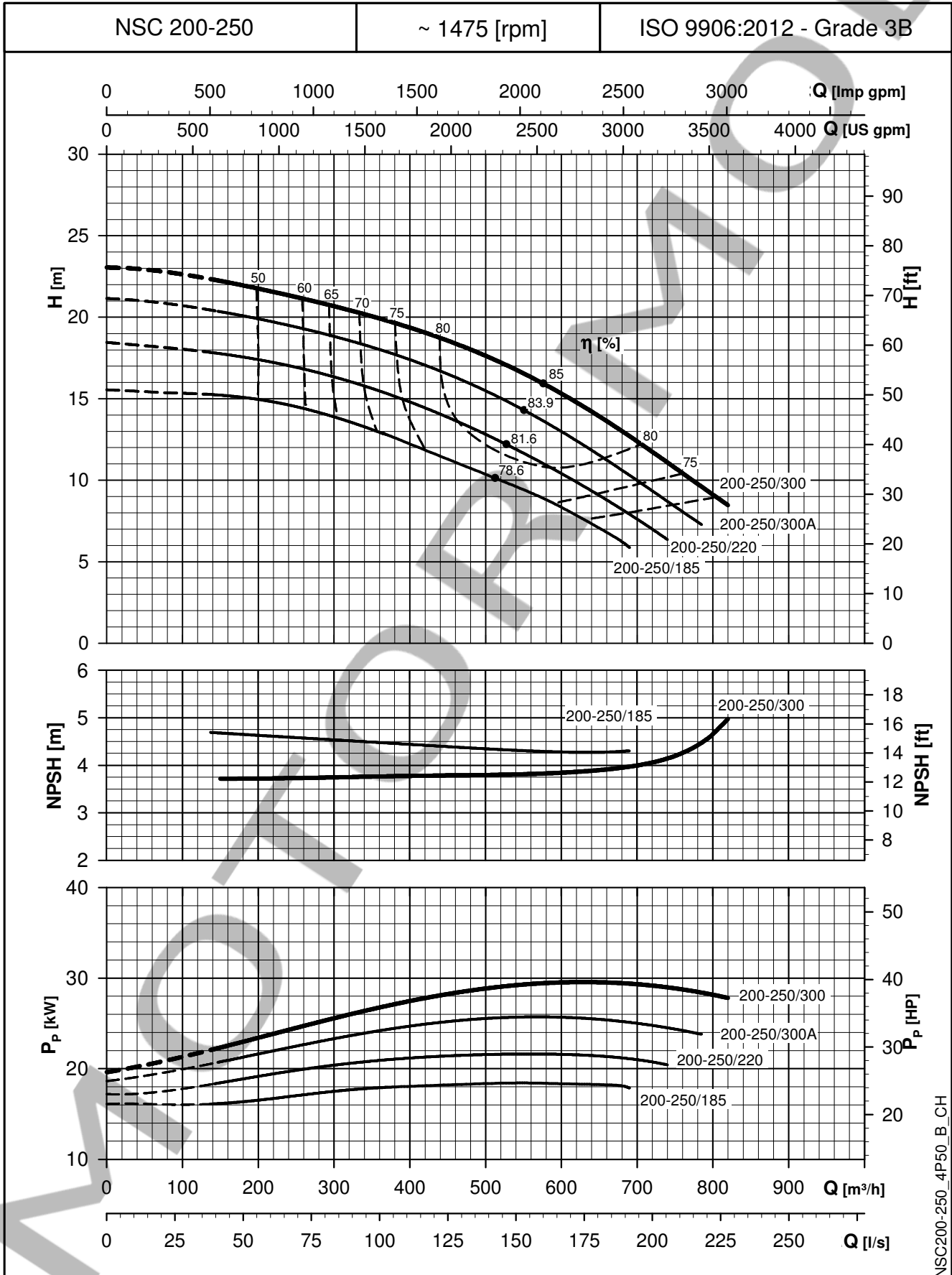

NSC200-250_4P50_B_CH

The NPSH values are laboratory values; for practical use we suggest increasing these values by 0,5 m.
 These performances are valid for liquids with density $\rho = 1,0 \text{ Kg/dm}^3$ and kinematic viscosity $\nu = 1 \text{ mm}^2/\text{sec}$.

e-NSC SERIES

OPERATING CHARACTERISTICS AT 50 Hz, 4 POLES

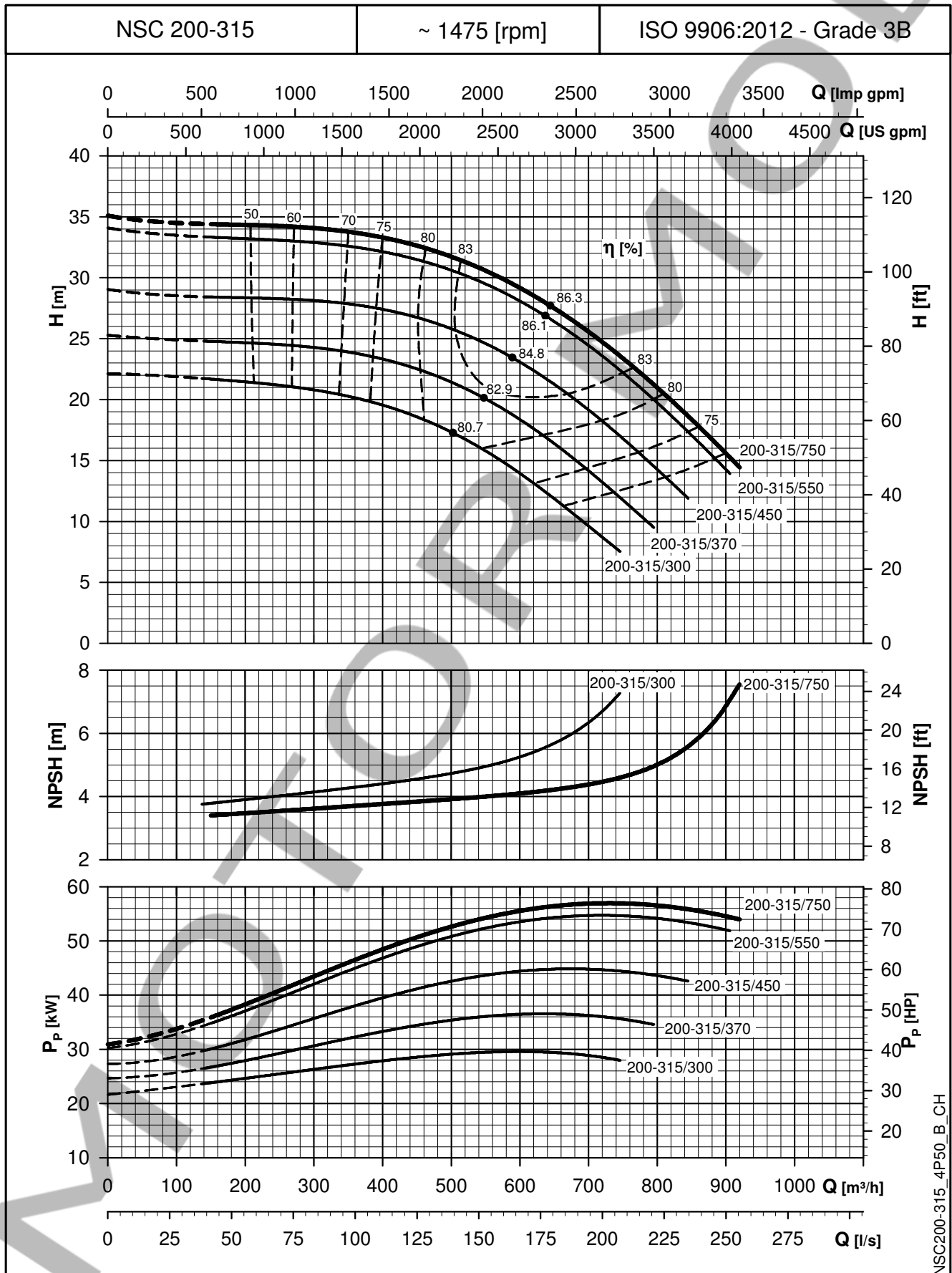

NSC200-315_4P50_B_CH

The NPSH values are laboratory values; for practical use we suggest increasing these values by 0,5 m.
 These performances are valid for liquids with density $\rho = 1,0 \text{ Kg/dm}^3$ and kinematic viscosity $\nu = 1 \text{ mm}^2/\text{sec}$.

e-NSC SERIES

OPERATING CHARACTERISTICS AT 50 Hz, 4 POLES

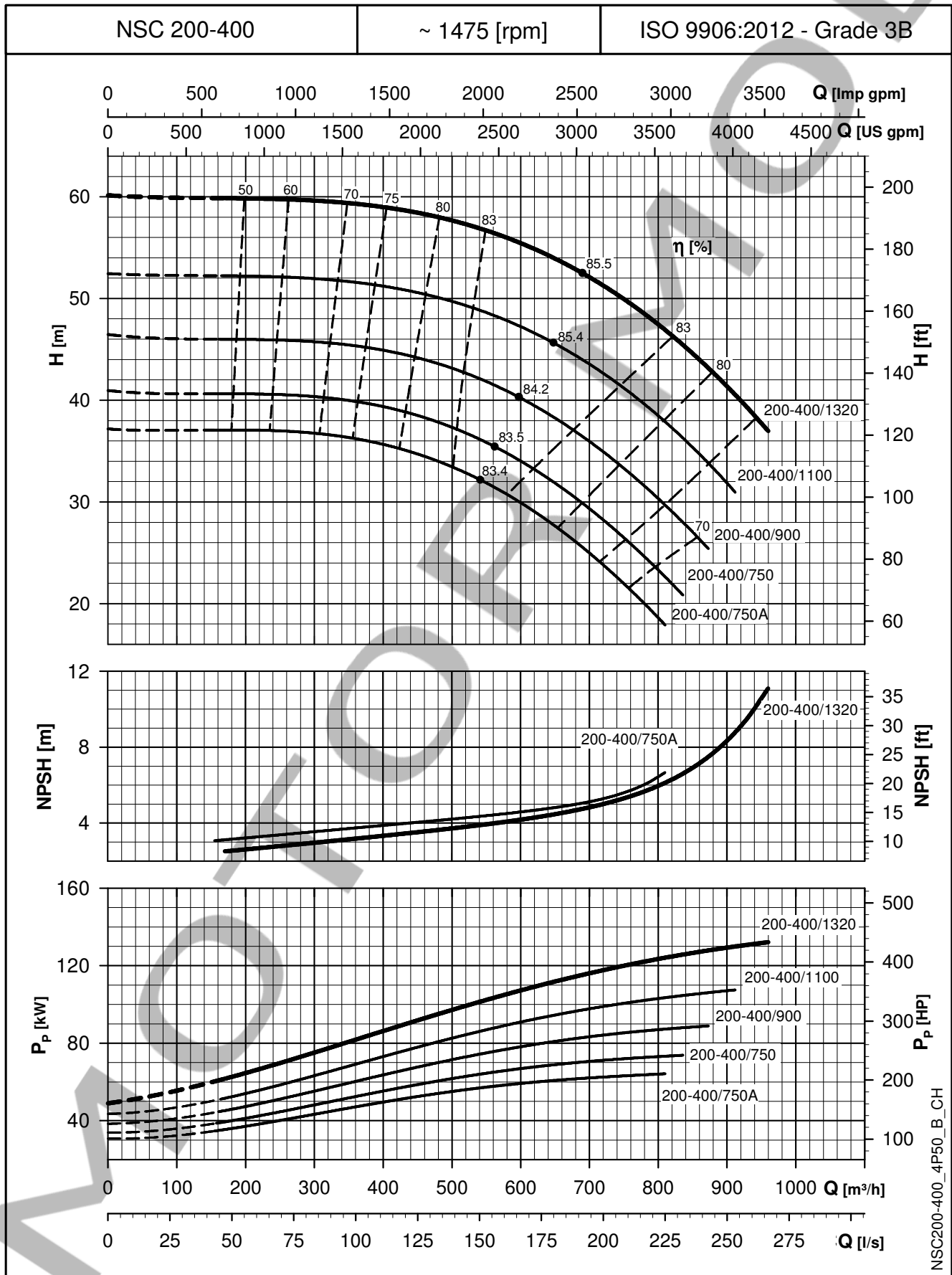

The NPSH values are laboratory values; for practical use we suggest increasing these values by 0,5 m.
 These performances are valid for liquids with density $\rho = 1,0 \text{ Kg/dm}^3$ and kinematic viscosity $\nu = 1 \text{ mm}^2/\text{sec}$.

e-NSC SERIES

OPERATING CHARACTERISTICS AT 50 Hz, 4 POLES

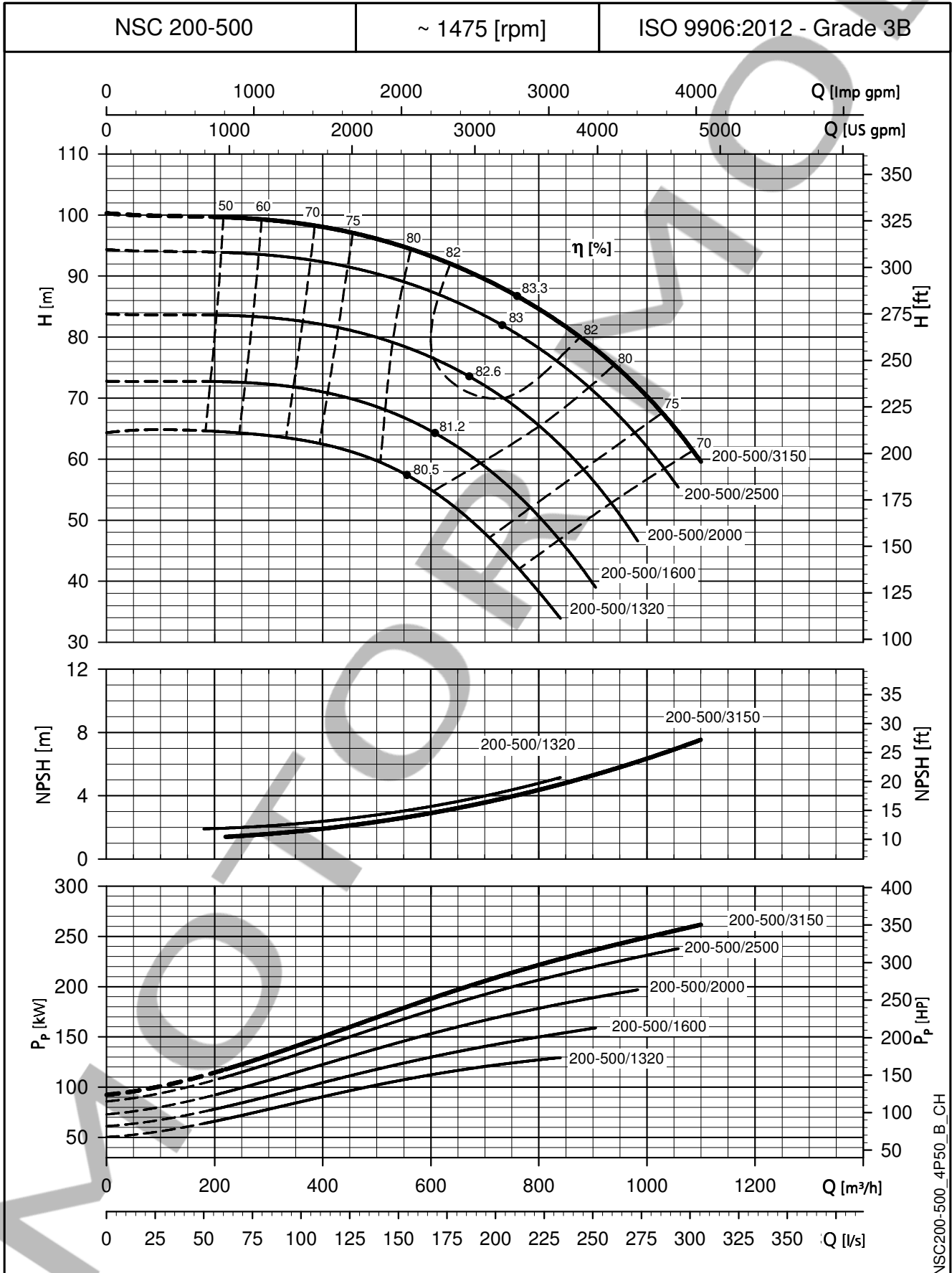

The NPSH values are laboratory values; for practical use we suggest increasing these values by 0,5 m.
 These performances are valid for liquids with density $\rho = 1,0 \text{ Kg/dm}^3$ and kinematic viscosity $\nu = 1 \text{ mm}^2/\text{sec}$.

NSCF 150 SERIES (MOUNTED ON BASE) DIMENSIONS AND WEIGHTS AT 50 Hz, 4 POLES

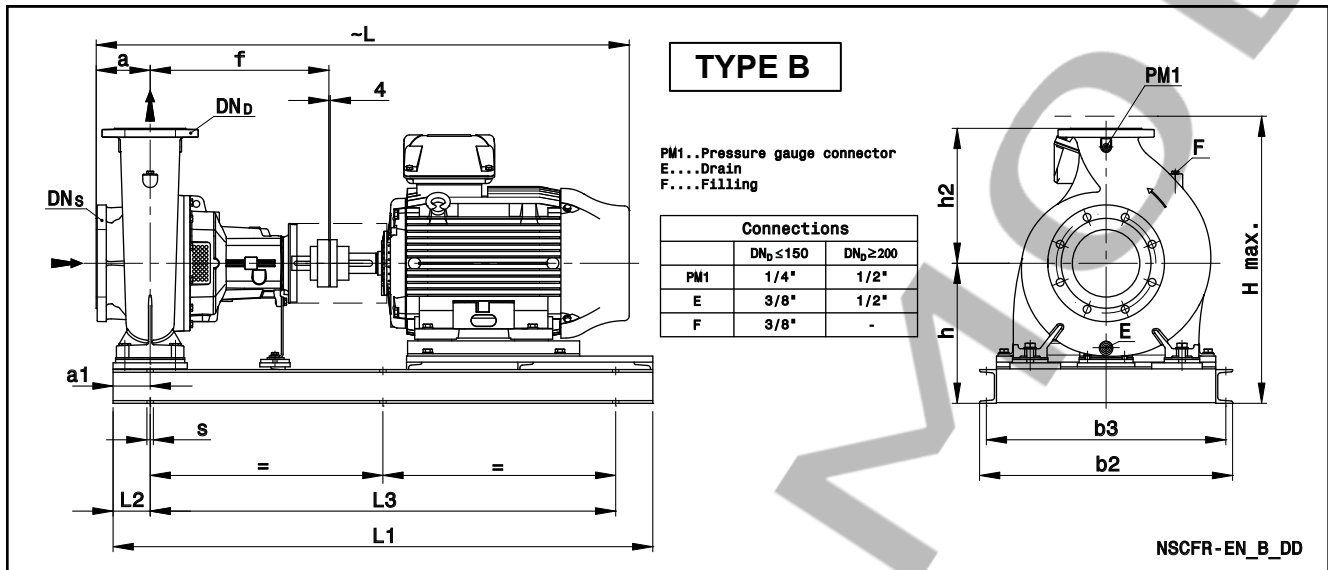

PUMP TYPE NSCF..4	TYPE	DIMENSIONS (mm)														H max	s FOR SCREWS	WEIGHT (kg) G	COUPLING TYPE
		DN _S	DN _D	a	a1	b2	b3	f	h	h2	L	L1	L2	L3					
150-200/110A/P	B	200	150	160	110	670	630	470	385	400	1238	1330	110	1110	785	6xØ19 (M16)	357	B95E	
150-200/110/P	B	200	150	160	110	670	630	470	385	400	1238	1330	110	1110	785	6xØ19 (M16)	357	B95E	
150-200/150A/P	B	200	150	160	110	670	630	470	385	400	1238	1330	110	1110	785	6xØ19 (M16)	402	B110E	
150-200/150/P	B	200	150	160	110	670	630	470	385	400	1238	1330	110	1110	785	6xØ19 (M16)	402	B110E	
150-250/150/P	B	200	150	160	110	670	630	530	385	400	1298	1430	110	1210	785	6xØ19 (M16)	413	B110C	
150-250/185/W	B	200	150	160	110	670	630	530	400	400	1358	1430	110	1210	800	6xØ19 (M16)	472	B110D	
150-250/220/W	B	200	150	160	110	670	630	530	400	400	1396	1430	110	1210	800	6xØ19 (M16)	490	B110D	
150-250/300/W	B	200	150	160	110	670	630	530	420	400	1461	1430	110	1210	820	6xØ19 (M16)	545	B125C	
150-315/300/W	B	200	150	160	110	670	630	530	420	400	1461	1430	110	1210	820	6xØ19 (M16)	551	B125C	
150-315/370/W	B	200	150	160	110	750	710	530	415	400	1580	1600	110	1380	815	6xØ19 (M16)	737	B140B	
150-315/450/W	B	200	150	160	110	750	710	530	415	400	1580	1600	110	1380	815	6xØ19 (M16)	765	B140B	
150-400/450/W	B	200	150	160	110	750	710	530	440	450	1580	1600	110	1380	890	6xØ19 (M16)	809	B140B	
150-400/550/W	B	200	150	160	110	750	710	530	440	450	1659	1600	110	1380	890	6xØ19 (M16)	893	B160B	
150-400/750/W	B	200	150	160	110	750	710	530	440	450	1765	1600	110	1380	912	6xØ19 (M16)	1103	B180B	
150-400/900/W	B	200	150	160	110	750	710	530	440	450	1765	1600	110	1380	912	6xØ19 (M16)	1151	B180B	
150-400/1100/W	B	200	150	160	110	750	710	530	440	450	1765	1600	110	1380	912	6xØ19 (M16)	1258	B180B	
150-500/900/W	B	200	150	180	165	860	810	770	565	500	2025	1750	165	1420	1065	6xØ26 (M20)	1384	B180C	
150-500/1100/W	B	200	150	180	165	860	810	770	585	500	2228	2000	165	1670	1115	6xØ26 (M20)	1678	B200A	
150-500/1320/W	B	200	150	180	165	860	810	770	585	500	2228	2000	165	1670	1115	6xØ26 (M20)	1763	B200A	
150-500/1600/W	B	200	150	180	165	860	810	770	585	500	2228	2000	165	1670	1115	6xØ26 (M20)	1820	B200A	
150-500/2000/W	B	200	150	180	165	860	810	770	585	500	2337	2000	165	1670	1160	6xØ26 (M20)	2005	B225A	

NOTE: Pumps with flanges according to EN 1092-2 as standard.

Nscf150_4p50-en_d_td

Available ASME B16.5 version on request. For flanges dimensions see drawing.

NSCF 200, 250, 300 SERIES (MOUNTED ON BASE) DIMENSIONS AND WEIGHTS AT 50 Hz, 4 POLES

PUMP TYPE NSCF..4	TYPE	DIMENSIONS (mm)															WEIGHT (kg) G	COUPLING TYPE
		DNS	DND	a	a1	b2	b3	f	h	h2	L	L1	L2	L3	H max	s FOR SCREWS		
200-250/185/W	B	250	200	180	110	670	630	530	460	475	1378	1450	110	1230	935	6xØ19 (M16)	527	B110D
200-250/220/W	B	250	200	180	110	670	630	530	460	475	1416	1450	110	1230	935	6xØ19 (M16)	545	B110D
200-250/300A/W	B	250	200	180	110	670	630	530	460	475	1481	1450	110	1230	935	6xØ19 (M16)	588	B125C
200-250/300/W	B	250	200	180	110	670	630	530	460	475	1481	1450	110	1230	935	6xØ19 (M16)	588	B125C
200-315/300/W	B	250	200	180	110	670	630	530	460	450	1481	1450	110	1230	910	6xØ19 (M16)	592	B125C
200-315/370/W	B	250	200	180	110	750	710	530	480	450	1600	1660	110	1440	930	6xØ19 (M16)	791	B140B
200-315/450/W	B	250	200	180	110	750	710	530	480	450	1600	1660	110	1440	930	6xØ19 (M16)	819	B140B
200-315/550/W	B	250	200	180	110	750	710	530	480	450	1679	1660	110	1440	930	6xØ19 (M16)	904	B160B
200-315/750/W	B	250	200	180	110	750	710	530	480	450	1785	1660	110	1440	952	6xØ19 (M16)	1113	B180B
200-400/750A/W	B	250	200	180	165	860	810	770	565	500	2025	1750	165	1420	1065	6xØ26 (M20)	1291	B180C
200-400/750/W	B	250	200	180	165	860	810	770	565	500	2025	1750	165	1420	1065	6xØ26 (M20)	1291	B180C
200-400/900/W	B	250	200	180	165	860	810	770	565	500	2025	1750	165	1420	1065	6xØ26 (M20)	1339	B180C
200-400/1100/W	B	250	200	180	165	860	810	770	585	500	2228	2000	165	1670	1115	6xØ26 (M20)	1633	B200A
200-400/1320/W	B	250	200	180	165	860	810	770	585	500	2228	2000	165	1670	1115	6xØ26 (M20)	1718	B200A
200-500/1320/W	B	250	200	200	165	860	810	770	635	560	2248	2000	165	1670	1195	6xØ26 (M20)	1778	B200A
200-500/1600/W	B	250	200	200	165	860	810	770	635	560	2248	2000	165	1670	1195	6xØ26 (M20)	1835	B200A
200-500/2000/W	B	250	200	200	165	860	810	770	635	560	2357	2000	165	1670	1210	6xØ26 (M20)	2019	B225A
200-500/2500/W	B	250	200	200	165	860	810	770	635	560	2357	2000	165	1670	1210	6xØ26 (M20)	2214	B225A
200-500/3150/W	B	250	200	200	165	1000	930	770	675	560	2456	2200	165	1870	1300	6xØ29 (M24)	2553	B250A
250-315/370/W	B	300	250	250	165	850	810	530	525	500	1670	1700	165	1370	1025	6xØ19 (M16)	905	B140B
250-315/450/W	B	300	250	250	165	850	810	530	525	500	1670	1700	165	1370	1025	6xØ19 (M16)	933	B140B
250-315/550/W	B	300	250	250	165	850	810	530	525	500	1749	1700	165	1370	1025	6xØ19 (M16)	1017	B160B
250-315/750/W	B	300	250	250	165	850	810	530	525	500	1855	1700	165	1370	1025	6xØ19 (M16)	1227	B180B
250-400/750/W	B	300	250	200	165	860	810	770	565	560	2045	1750	165	1420	1125	6xØ26 (M20)	1328	B180C
250-400/900/W	B	300	250	200	165	860	810	770	565	560	2045	1750	165	1420	1125	6xØ26 (M20)	1376	B180C
250-400/1100/W	B	300	250	200	165	860	810	770	585	560	2248	2000	165	1670	1145	6xØ26 (M20)	1670	B200A
250-400/1320/W	B	300	250	200	165	860	810	770	585	560	2248	2000	165	1670	1145	6xØ26 (M20)	1755	B200A
250-400/1600/W	B	300	250	200	165	860	810	770	585	560	2248	2000	165	1670	1145	6xØ26 (M20)	1812	B200A
250-400/2000/W	B	300	250	200	165	860	810	770	585	560	2357	2000	165	1670	1160	6xØ26 (M20)	1997	B225A
250-500/1600/W	B	300	250	200	165	860	810	770	635	670	2248	2000	165	1670	1305	6xØ26 (M20)	1886	B200A
250-500/2000/W	B	300	250	200	165	860	810	770	635	670	2357	2000	165	1670	1305	6xØ26 (M20)	2070	B225A
250-500/2500/W	B	300	250	200	165	860	810	770	635	670	2357	2000	165	1670	1305	6xØ26 (M20)	2265	B225A
250-500/3150/W	B	300	250	200	165	1000	930	770	675	670	2456	2200	165	1870	1345	6xØ29 (M24)	2604	B250A
250-500/3550/W	B	300	250	200	165	1000	930	770	675	670	2456	2200	165	1870	1345	6xØ29 (M24)	2710	B250A
300-350/750A/W	B	350	300	250	200	960	910	800	620	600	2125	1850	200	1450	1220	6xØ26 (M20)	1514	B180C
300-350/750/W	B	350	300	250	200	960	910	800	620	600	2125	1850	200	1450	1220	6xØ26 (M20)	1514	B180C
300-350/900/W	B	350	300	250	200	960	910	800	620	600	2125	1850	200	1450	1220	6xØ26 (M20)	1562	B180C
300-350/1100/W	B	350	300	250	200	960	910	800	640	600	2328	2100	200	1700	1240	6xØ26 (M20)	1871	B200A
300-400/1100/W	B	350	300	250	200	960	910	800	640	600	2328	2100	200	1700	1240	6xØ26 (M20)	1875	B200A
300-400/1320/W	B	350	300	250	200	960	910	800	640	600	2328	2100	200	1700	1240	6xØ26 (M20)	1960	B200A
300-400/1600/W	B	350	300	250	200	960	910	800	640	600	2328	2100	200	1700	1240	6xØ26 (M20)	2017	B200A
300-400/2000/W	B	350	300	250	200	960	910	800	640	600	2437	2100	200	1700	1240	6xØ26 (M20)	2201	B225A
300-400/2500/W	B	350	300	250	200	960	910	800	640	600	2437	2100	200	1700	1240	6xØ26 (M20)	2396	B225A
300-450/1600/W	B	350	300	250	200	960	910	800	665	630	2328	2100	200	1700	1295	6xØ26 (M20)	2058	B200A
300-450/2000/W	B	350	300	250	200	960	910	800	665	630	2437	2100	200	1700	1295	6xØ26 (M20)	2243	B225A
300-450/2500/W	B	350	300	250	200	960	910	800	665	630	2437	2100	200	1700	1295	6xØ26 (M20)	2438	B225A
300-450/3150/W	B	350	300	250	200	1000	930	800	705	630	2536	2250	200	1850	1335	6xØ29 (M24)	2754	B250A

NOTE: Pumps with flanges according to EN 1092-2 as standard.

Nscf200-300_4p50-en_d_td

Available ASME B16.5 version on request. For flanges dimensions see drawing.