

50 Hz



## e-NSC Series

HORIZONTAL CENTRIFUGAL ELECTRIC PUMPS  
EQUIPPED WITH **IE3** MOTORS

ErP 2009/125/EC

Cod. 191002951 Rev. G Ed.07/2017

 **LOWARA**  
a xylem brand

### e-NSC 65, 80 SERIES

### HYDRAULIC PERFORMANCE TABLE AT 50 Hz, 2 POLES

PUMP TYPE	P <sub>N</sub> kW	Ø Impeller (mm)				Q = DELIVERY													
		STD (1)	B (2)	O (3)	η <sub>p</sub> % (3)	l/s	6	11,8	17,1	22,4	27,8	33,1	38,4	43,7	49,0	54,4	59,7	65	
						m <sup>3</sup> /h	0	23	42	62	81	100	119	138	157	177	196	215	234
H = TOTAL HEAD METRES COLUMN OF WATER																			
65-125/40	4	113	112	○	77,9	14,4		14,5	13,7	12,2	10,3	8,0							
65-125/55	5,5	127	125,5	○	79,7	19,5		19,4	18,4	16,7	14,5	11,7							
65-125/75	7,5	137	136	○	80,3	23,8		23,9	23,2	21,7	19,6	16,8	13,7	10,5					
65-125/92	9,2	146	143	○	81,4	28,3		28,1	27,4	26,2	24,4	22,1	19,2	16,1					
65-125/110A	11	146	143	○	81,4	28,3		28,1	26,7	24,4	21,0	16,8	12,2	16,1					
65-125/110	11	148	146	●	81,9	29,5		29,1	28,3	27,2	25,6	23,6	21,0	18,0	14,5				
65-160/75	7,5	145	144	○	79,1	27,0		26,5	25,3	23,2	20,2	16,6							
65-160/92	9,2	151	152	○	80,9	29,8		29,4	28,5	26,7	23,9	20,4	16,4						
65-160/110A	11	151	152	○	80,9	29,8		29,4	28,5	26,7	23,9	20,4	16,4						
65-160/110	11	159	160	○	81,4	33,3		33,0	32,1	30,5	27,9	24,6	20,5						
65-160/150	15	175	176	○	82,4	41,3		41,1	40,4	39,2	37,1	34,3	30,7	26,5					
65-160/185	18,5	180	180	●	83,4	44,7		44,3	43,7	42,5	40,7	38,2	35,1	31,3	26,8				
65-200/110	11	165	162	○	73,0	36,4		35,6	33,8	30,6	25,8	19,5							
65-200/150	15	177	177	○	77,4	43,1		42,8	41,6	39,1	35,2	29,7	22,8						
65-200/185	18,5	189	189	○	78,5	49,9		49,4	48,3	46,1	42,7	37,8	31,4						
65-200/220	22	199	199	○	79,2	55,9		55,6	54,6	52,7	49,6	45,0	38,9	31,0					
65-200/300	30	220	218	●	80,1	70,2		69,6	68,7	67,3	65,0	61,7	57,2	51,1	43,1				
65-250/220	22	195	192	○	76,0	51,0		53,7	52,4	50,0	46,7	42,3	36,6	29,1					
65-250/300	30	215	213	○	76,8	63,7		66,6	65,5	63,4	60,5	56,6	51,6	45,0	36,4				
65-250/370	37	229	226	○	79,1	73,3		77,2	76,4	74,6	72,0	68,7	64,5	59,1	52,0	42,5			
65-250/450	45	243	240	○	79,4	83,7		87,8	87,1	85,5	83,3	80,6	77,0	72,4	66,3	57,9	46,3		
65-250/550	55	258	255	●	80,3	98,5		99,7	99,1	97,9	95,9	93,3	89,8	85,2	79,4	72,0	62,8	51,4	
65-315/550	55	272	272	○	68,0	103,6	103,8	103,3	101,6	98,7	94,7	89,6	83,4	75,7	66,0				
65-315/750	75	298	298	○	68,9	126,1		125,7	124,5	122,0	118,4	113,7	108,1	101,5	93,6	83,7			
65-315/900	90	315	315	●	69,2	142,4		141,7	140,8	138,7	135,4	130,9	125,4	119,0	111,5	102,7	91,7		

PUMP TYPE	P <sub>N</sub> kW	Ø Impeller (mm)				Q = DELIVERY													
		STD (1)	B (2)	O (3)	η <sub>p</sub> % (3)	l/s	11	18,4	26,2	34,1	41,9	49,8	57,7	65,5	73,4	81,2	89,1	97	
						m <sup>3</sup> /h	0	38	66	94	123	151	179	208	236	264	292	321	349
H = TOTAL HEAD METRES COLUMN OF WATER																			
80-160/110	11	144	144	○	76,0	26,8		25,7	23,8	21,4	18,5	15,3	12,0						
80-160/150	15	158	158	○	79,5	33,4		32,4	31,1	29,0	26,3	22,9	19,1	15,1					
80-160/185	18,5	168	168	○	80,3	38,0		37,2	36,0	34,0	31,2	27,8	23,8	19,6					
80-160/220	22	177	177	●	80,8	42,3		41,6	40,5	38,8	36,4	33,3	29,5	25,3	20,7				
80-200/220	22	181	177	○	79,7	43,5		43,7	42,8	40,9	38,0	34,2	29,7						
80-200/300	30	195	192	○	81,8	52,1		52,1	51,6	50,2	47,8	44,3	40,0	34,9					
80-200/370	37	208	204	○	82,6	60,5		60,2	59,5	58,0	55,8	52,7	48,7	43,8					
80-200/450	45	219	216	●	83,3	67,8		67,7	67,1	66,0	64,1	61,3	57,7	53,1	47,6				
80-250/370	37	214	211	○	80,6	65,0		65,8	64,4	62,0	58,8	54,6	49,5						
80-250/450	45	227	224	○	81,8	73,9		75,1	74,3	72,4	69,4	65,2	60,1	54,2					
80-250/550	55	241	238	○	82,3	83,5		85,1	84,3	82,6	79,9	76,0	71,2	65,5	59,0				
80-250/750	75	259	256	●	83,6	98,8		98,1	96,9	94,9	91,8	87,6	82,2	75,9	68,6				
80-316/900	90	280	280	○	76,3	110,7	110,2	110,0	109,9	109,0	106,7	102,7	97,1	90,3	82,8	74,1			
80-316/1100	110	298	298	○	76,7	125,2		124,5	124,3	123,8	122,5	119,9	115,6	109,8	102,5	94,0	84,5		
80-316/1320	132	310	310	○	77,7	135,1		134,7	134,6	134,1	132,9	130,8	127,4	122,7	116,5	108,7	99,5		
80-316/1600	160	321	321	●	77,9	146,1		145,4	145,3	144,9	143,8	141,8	138,6	134,2	128,5	121,3	112,7	102,7	

Hydraulic performances in compliance with ISO 9906:2012 - Grade 3B (ex ISO 9906:1999 - Annex A)

Nsc-65-80\_2p50-en\_e\_th

(1) STD = Cast iron/Stainless steel - B = Bronze (2) ● = Full impeller diameter - ○ = Trimmed impeller diameter (3) Hydraulic efficiency of pump.

**e-NSC SERIES**

**OPERATING CHARACTERISTICS AT 50 Hz, 2 POLES**

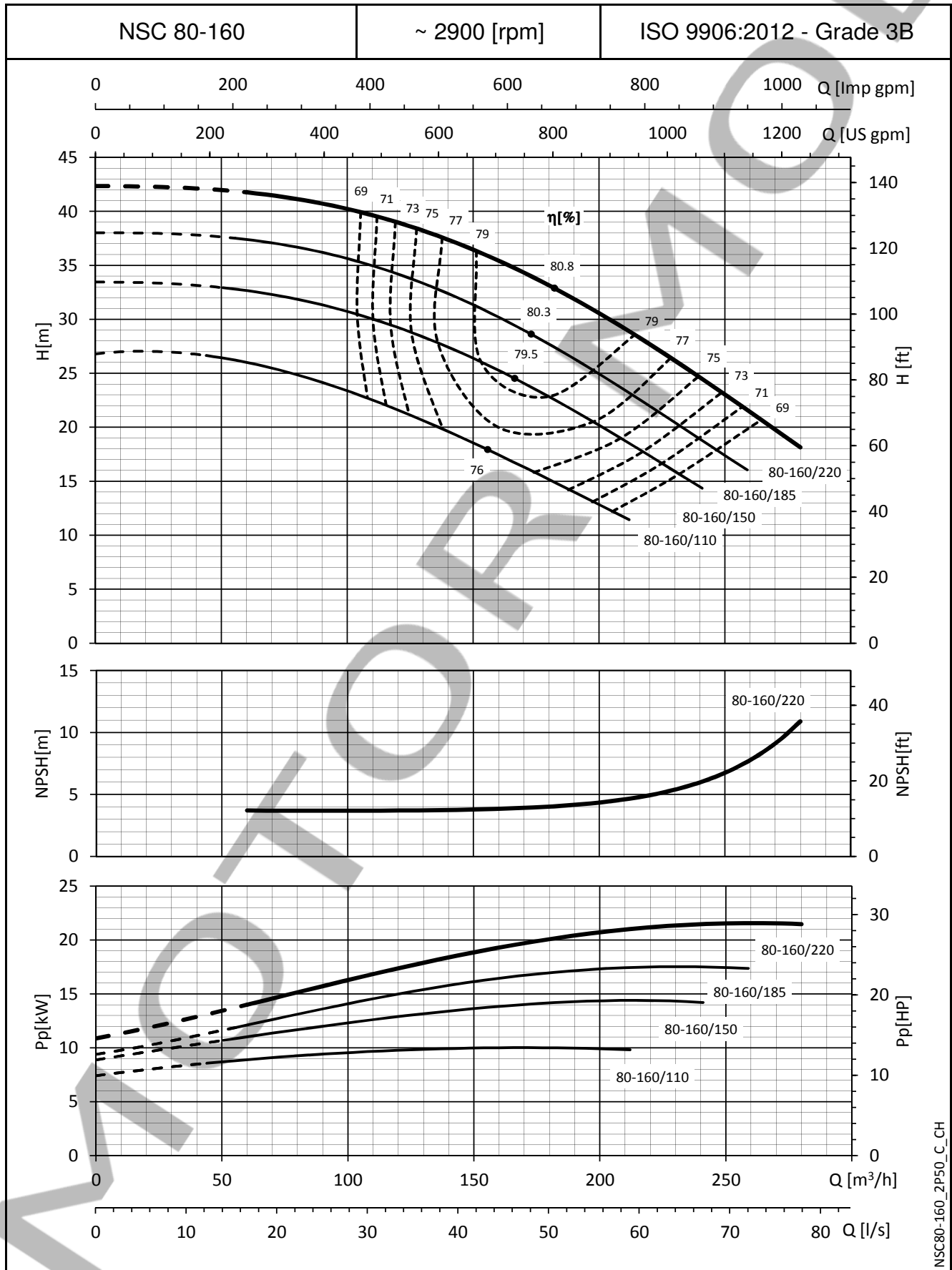

NSC80-160\_2P50\_C\_CH

The NPSH values are laboratory values; for practical use we suggest increasing these values by 0,5 m.  
 These performances are valid for liquids with density  $\rho = 1,0 \text{ Kg/dm}^3$  and kinematic viscosity  $\nu = 1 \text{ mm}^2/\text{sec}$ .

**e-NSC SERIES**

**OPERATING CHARACTERISTICS AT 50 Hz, 2 POLES**

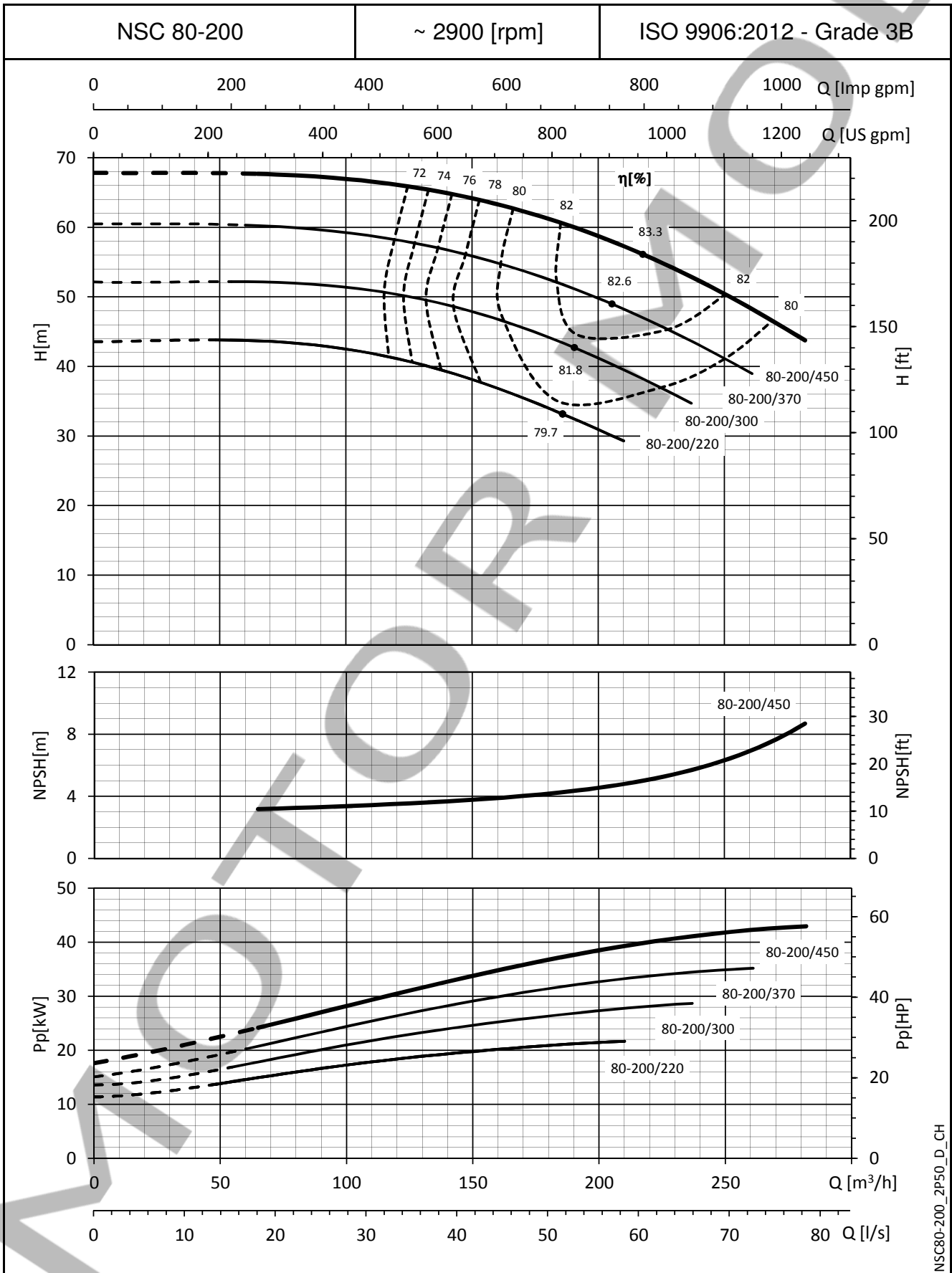

NSC80-200\_2P50\_D\_CH

The NPSH values are laboratory values; for practical use we suggest increasing these values by 0,5 m.  
 These performances are valid for liquids with density  $\rho = 1,0 \text{ Kg/dm}^3$  and kinematic viscosity  $\nu = 1 \text{ mm}^2/\text{sec}$ .

**e-NSC SERIES**

**OPERATING CHARACTERISTICS AT 50 Hz, 2 POLES**

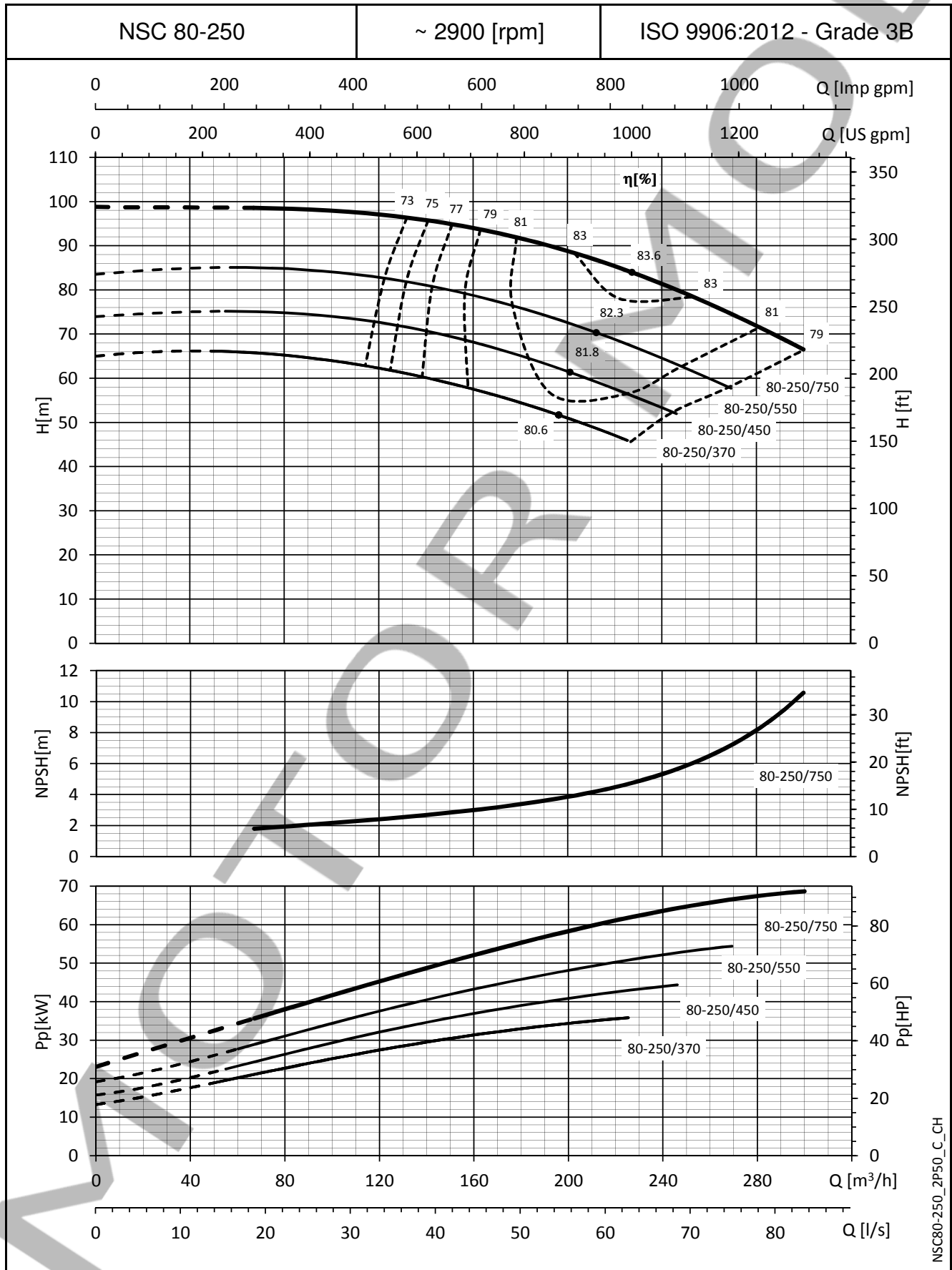

NSC80-250\_2P50\_C\_CH

The NPSH values are laboratory values; for practical use we suggest increasing these values by 0,5 m.  
 These performances are valid for liquids with density  $\rho = 1,0 \text{ Kg/dm}^3$  and kinematic viscosity  $\nu = 1 \text{ mm}^2/\text{sec}$ .

**e-NSC SERIES**

**OPERATING CHARACTERISTICS AT 50 Hz, 2 POLES**

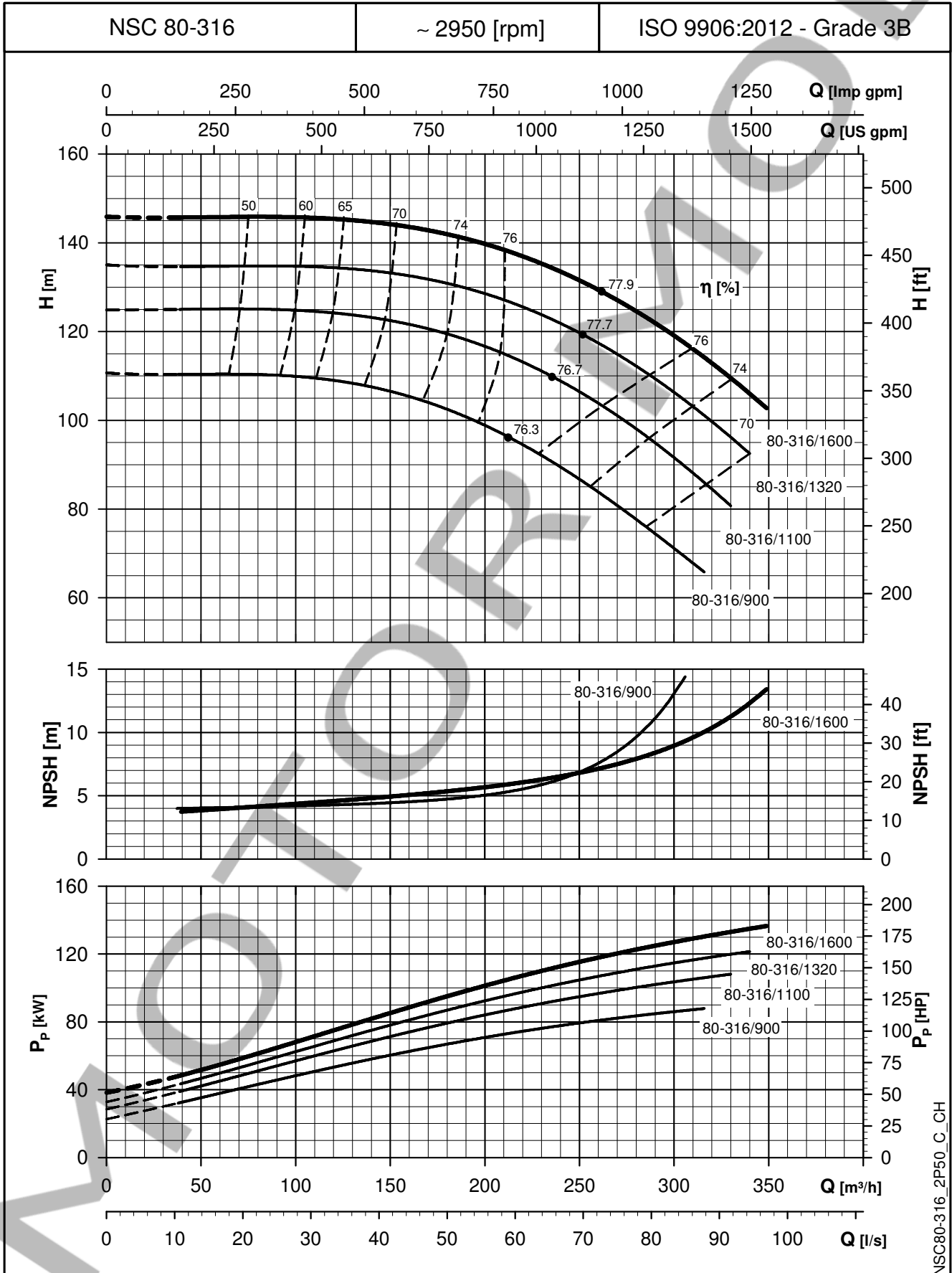

NSC80-316\_2P50\_C\_CH

The NPSH values are laboratory values; for practical use we suggest increasing these values by 0,5 m.  
 These performances are valid for liquids with density  $\rho = 1,0 \text{ Kg/dm}^3$  and kinematic viscosity  $\nu = 1 \text{ mm}^2/\text{sec}$ .

**NSCF 80, 100, 125 SERIES (MOUNTED ON BASE)  
DIMENSIONS AND WEIGHTS AT 50 Hz, 2 POLES**

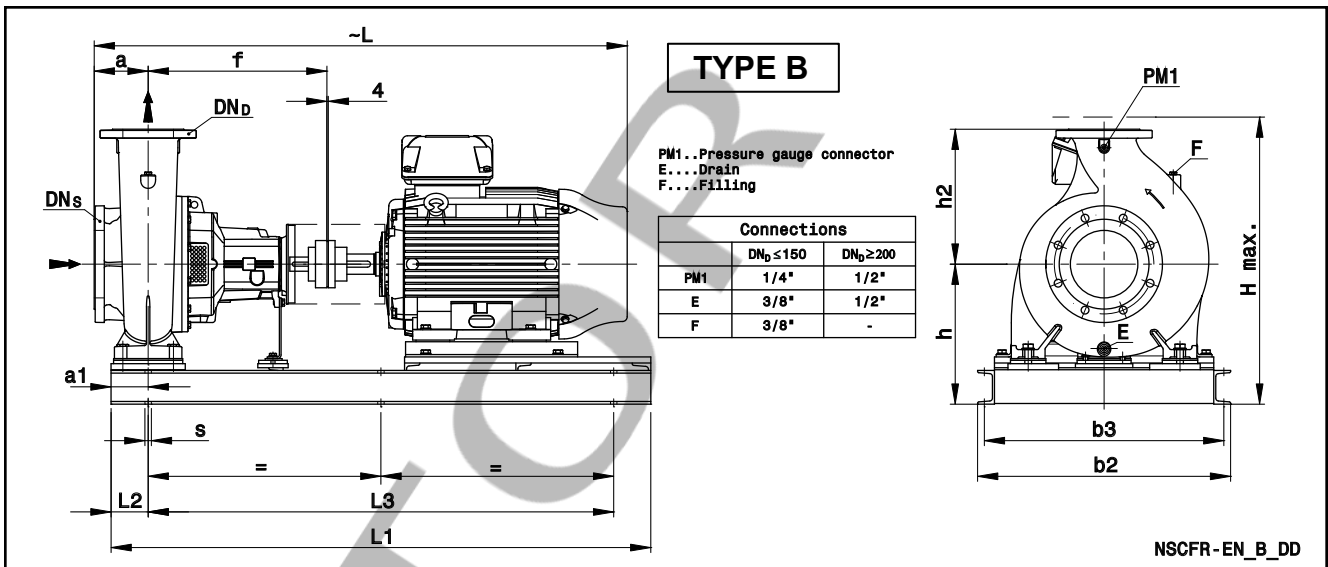
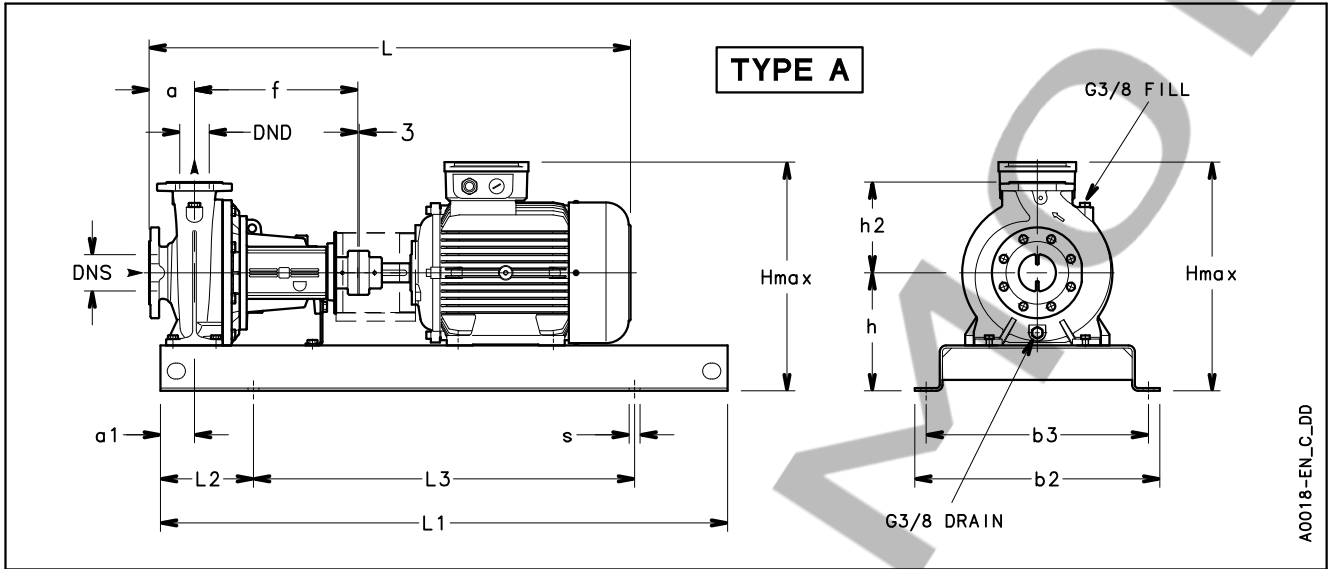

## NSCF 80, 100, 125 SERIES (MOUNTED ON BASE) DIMENSIONS AND WEIGHTS AT 50 Hz, 2 POLES

PUMP TYPE NSCF..2	TYPE	DIMENSIONS (mm)														H max	s FOR SCREWS	WEIGHT (kg) G	COUPLING TYPE
		DNS	DND	a	a1	b2	b3	f	h	h2	L	L1	L2	L3					
80-160/110/P	A	100	80	125	75	540	490	360	280	225	1092	1250	205	840	520	4xØ24 (M20)	194	B95B	
80-160/150/P	A	100	80	125	75	540	490	360	280	225	1092	1250	205	840	520	4xØ24 (M20)	211	B95B	
80-160/185/P	A	100	80	125	75	540	490	360	280	225	1092	1250	205	840	520	4xØ24 (M20)	224	B95B	
80-160/220/W	A	100	80	125	75	540	490	360	280	225	1152	1250	205	840	559	4xØ24 (M20)	291	B110A	
80-200/220/W	A	100	80	125	75	540	490	470	280	250	1262	1250	205	840	559	4xØ24 (M20)	308	B110B	
80-200/300/W	A	100	80	125	75	610	550	470	310	250	1365	1400	230	940	627	4xØ28 (M24)	390	B125B	
80-200/370/W	A	100	80	125	75	610	550	470	310	250	1365	1400	230	940	627	4xØ28 (M24)	411	B125B	
80-200/450/W	A	100	80	125	75	610	550	470	365	250	1454	1400	230	940	749	4xØ28 (M24)	562	B125B	
80-250/370/W	A	100	80	125	90	610	550	470	310	280	1365	1400	230	940	627	4xØ28 (M24)	414	B125B	
80-250/450/W	A	100	80	125	90	610	550	470	365	280	1454	1400	230	940	749	4xØ28 (M24)	565	B125B	
80-250/550/W	A	100	80	125	90	660	600	470	390	280	1563	1600	270	1060	792	4xØ28 (M24)	674	B140A	
80-250/750/W	A	100	80	125	90	730	670	470	420	280	1669	1800	300	1200	892	4xØ28 (M24)	942	B160A	
80-316/900/W	B	100	80	125	110	750	710	530	440	315	1730	1600	110	1380	912	6xØ19 (M16)	1061	B160B	
80-316/1100/W	B	100	80	125	110	860	810	530	505	315	1903	1850	110	1630	1035	6xØ26 (M20)	1340	B160B	
80-316/1320/W	B	100	80	125	110	860	810	530	505	315	1903	1850	110	1630	1035	6xØ26 (M20)	1426	B160B	
80-316/1600/W	B	100	80	125	110	860	810	530	505	315	1903	1850	110	1630	1035	6xØ26 (M20)	1507	B160B	
100-160/150/P	B	125	100	125	110	670	630	470	365	280	1203	1330	110	1110	645	6xØ19 (M16)	304	B95E	
100-160/185/P	B	125	100	125	110	670	630	470	365	280	1203	1330	110	1110	645	6xØ19 (M16)	312	B95E	
100-160/220/W	B	125	100	125	110	670	630	470	385	280	1263	1330	110	1110	665	6xØ19 (M16)	385	B110B	
100-160/300/W	B	125	100	125	110	560	520	470	330	280	1366	1350	110	1130	647	6xØ19 (M16)	422	B125B	
100-200/300/W	B	125	100	125	110	560	520	470	330	280	1366	1350	110	1130	647	6xØ19 (M16)	430	B125B	
100-200/370/W	B	125	100	125	110	560	520	470	330	280	1366	1350	110	1130	647	6xØ19 (M16)	451	B125B	
100-200/450/W	B	125	100	125	110	560	520	470	355	280	1455	1350	110	1130	739	6xØ19 (M16)	610	B125B	
100-200/550/W	B	125	100	125	110	750	710	470	405	280	1564	1550	110	1330	807	6xØ19 (M16)	735	B140A	
100-250/450/W	B	125	100	140	110	560	520	470	355	280	1470	1350	110	1130	739	6xØ19 (M16)	612	B125B	
100-250/550/W	B	125	100	140	110	750	710	470	405	280	1579	1550	110	1330	807	6xØ19 (M16)	738	B140A	
100-250/750/W	B	125	100	140	110	750	710	470	390	280	1685	1550	110	1330	862	6xØ19 (M16)	956	B160A	
100-250/900/W	B	125	100	140	110	750	710	470	390	280	1685	1550	110	1330	862	6xØ19 (M16)	991	B160A	
100-316/1100/W	B	125	100	140	110	860	810	530	505	315	1918	1850	110	1630	1035	6xØ26 (M20)	1343	B160B	
100-316/1320/W	B	125	100	140	110	860	810	530	505	315	1918	1850	110	1630	1035	6xØ26 (M20)	1429	B160B	
100-316/1600/W	B	125	100	140	110	860	810	530	505	315	1918	1850	110	1630	1035	6xØ26 (M20)	1510	B160B	
125-200/450/W	B	150	125	140	110	560	520	470	355	315	1470	1350	110	1130	739	6xØ19 (M16)	617	B125B	
125-200/550/W	B	150	125	140	110	750	710	470	405	315	1579	1550	110	1330	807	6xØ19 (M16)	743	B140A	
125-200/750/W	B	150	125	140	110	750	710	470	405	315	1685	1550	110	1330	877	6xØ19 (M16)	970	B160A	
125-200/900/W	B	150	125	140	110	750	710	470	405	315	1685	1550	110	1330	877	6xØ19 (M16)	1005	B160A	
125-315/1100/W	B	150	125	140	110	860	810	530	505	355	1918	1850	110	1630	1035	6xØ26 (M20)	1344	B160B	
125-315/1320/W	B	150	125	140	110	860	810	530	505	355	1918	1850	110	1630	1035	6xØ26 (M20)	1430	B160B	
125-315/1600/W	B	150	125	140	110	860	810	530	505	355	1918	1850	110	1630	1035	6xØ26 (M20)	1511	B160B	
125-315/2000/W	B	150	125	140	110	860	810	530	505	355	2027	1850	110	1630	1080	6xØ26 (M20)	1692	B180A	

NOTE: Pumps with flanges according to EN 1092-2 as standard.

Nscf80-125-2p50-en\_c\_td

Available ASME B16.5 version on request. For flanges dimensions see drawing.