

50 Hz



e-NSC Series

HORIZONTAL CENTRIFUGAL ELECTRIC PUMPS
EQUIPPED WITH **IE3** MOTORS

ErP 2009/125/EC

Cod. 191002951 Rev. G Ed.07/2017

 **LOWARA**
a xylem brand

e-NSC 100, 125 SERIES

HYDRAULIC PERFORMANCE TABLE AT 50 Hz, 2 POLES

PUMP TYPE	P _N kW	Ø Impeller (mm)				Q = DELIVERY												
		STD (1)	B (2)	○ (3)	ηp %	l/s	11	22,5	33,8	45,1	56,3	67,6	78,9	90,2	101,4	112,7	124	135
						m ³ /h	0	40	81	122	162	203	243	284	325	365	406	446
H = TOTAL HEAD METRES COLUMN OF WATER																		
100-160/150	15	144	144	○	76,7	24,7	24,8	24,6	23,8	22,3	19,9	16,6	12,6					
100-160/185	18,5	156	156	○	79,7	29,1		28,7	28,2	26,9	24,6	21,3	17,1					
100-160/220	22	167	167	○	80,5	34,1		33,4	32,8	31,5	29,3	26,0	21,7	16,7				
100-160/300	30	187	187	●	83,8	44,1		42,7	41,9	40,6	38,7	35,9	32,1	27,1				
100-200/300	30	188	188	○	79,7	46,5		45,7	44,8	42,7	39,2	34,3	28,1	21,0				
100-200/370	37	202	202	○	82,0	53,9		53,4	52,8	51,2	48,2	43,8	38,0	31,0				
100-200/450	45	213	213	○	83,4	60,4		59,8	59,5	58,3	55,7	51,8	46,4	39,7	31,8			
100-200/550	55	227	227	●	84,6	69,2		68,9	68,2	66,9	64,7	61,3	56,6	50,6	43,0			
100-250/450	45	213	213	○	80,4	58,7		58,3	58,0	56,9	54,4	50,3	44,8	38,5	31,5			
100-250/550	55	227	227	○	83,1	67,8		67,7	67,4	66,2	64,0	60,5	55,7	49,6	42,4			
100-250/750	75	249	249	○	84,3	82,8		82,7	82,5	81,8	80,0	76,9	72,4	66,7	60,2	52,9		
100-250/900	90	259	259	●	85,0	90,1		90,1	89,8	88,8	87,0	84,0	79,8	74,4	67,6	59,6		
100-316/1100	110	270	270	○	78,6	104,7		104,3	103,5	101,9	99,3	95,6	90,5	83,7	74,6	62,4		
100-316/1320	132	286	286	○	79,9	116,6		116,2	115,7	114,2	111,8	108,5	104,2	98,6	91,4	81,5	67,3	
100-316/1600	160	302	302	●	80,8	131,3		130,9	130,8	129,9	128,0	124,8	120,4	115,0	108,8	101,5	91,8	77,0

PUMP TYPE	P _N kW	Ø Impeller (mm)				Q = DELIVERY												
		STD (1)	B (2)	○ (3)	ηp %	l/s	24	37,6	51,6	65,6	79,6	93,6	107,7	121,7	135,7	149,7	163,8	178
						m ³ /h	0	85	135	186	236	287	337	388	438	489	539	590
H = TOTAL HEAD METRES COLUMN OF WATER																		
125-200/450	45	179	179	○	80,4	34,9	34,5	34,5	34,4	34,2	33,8	33,1	31,7	29,6	26,6	22,3		
125-200/550	55	195	195	○	83,1	43,1		43,0	43,0	42,7	42,1	40,9	39,0	36,2	32,6	28,4		
125-200/750	75	215	215	○	84,4	55,1		54,9	54,9	54,7	54,2	53,2	51,6	49,3	46,1	42,0	37,1	
125-200/900	90	225	225	●	85,7	61,8		61,6	61,5	61,2	60,7	59,8	58,3	56,1	53,0	49,1	44,5	39,3
125-315/1100	110	250	250	○	81,4	84,0		83,8	83,2	81,6	78,7	74,3	68,2	60,4	51,0			
125-315/1320	132	265	265	○	81,1	96,8		96,7	96,2	95,0	92,6	89,0	83,9	77,1	68,4			
125-315/1600	160	280	280	○	81,9	109,8		109,8	109,5	108,6	106,9	104,0	99,7	93,8	86,1	76,4		
125-315/2000	200	290	290	●	82,9	118,9		119,0	118,8	118,1	116,7	114,3	110,6	105,4	98,3	89,3	78,3	

Hydraulic performances in compliance with ISO 9906:2012 - Grade 3B (ex ISO 9906:1999 - Annex A)

Nsc-100-125_2p50-en_d_th

(1) STD = Cast iron/Stainless steel - B = Bronze (2) ● = Full impeller diameter - ○ = Trimmed impeller diameter (3) Hydraulic efficiency of pump.

e-NSC SERIES

OPERATING CHARACTERISTICS AT 50 Hz, 2 POLES

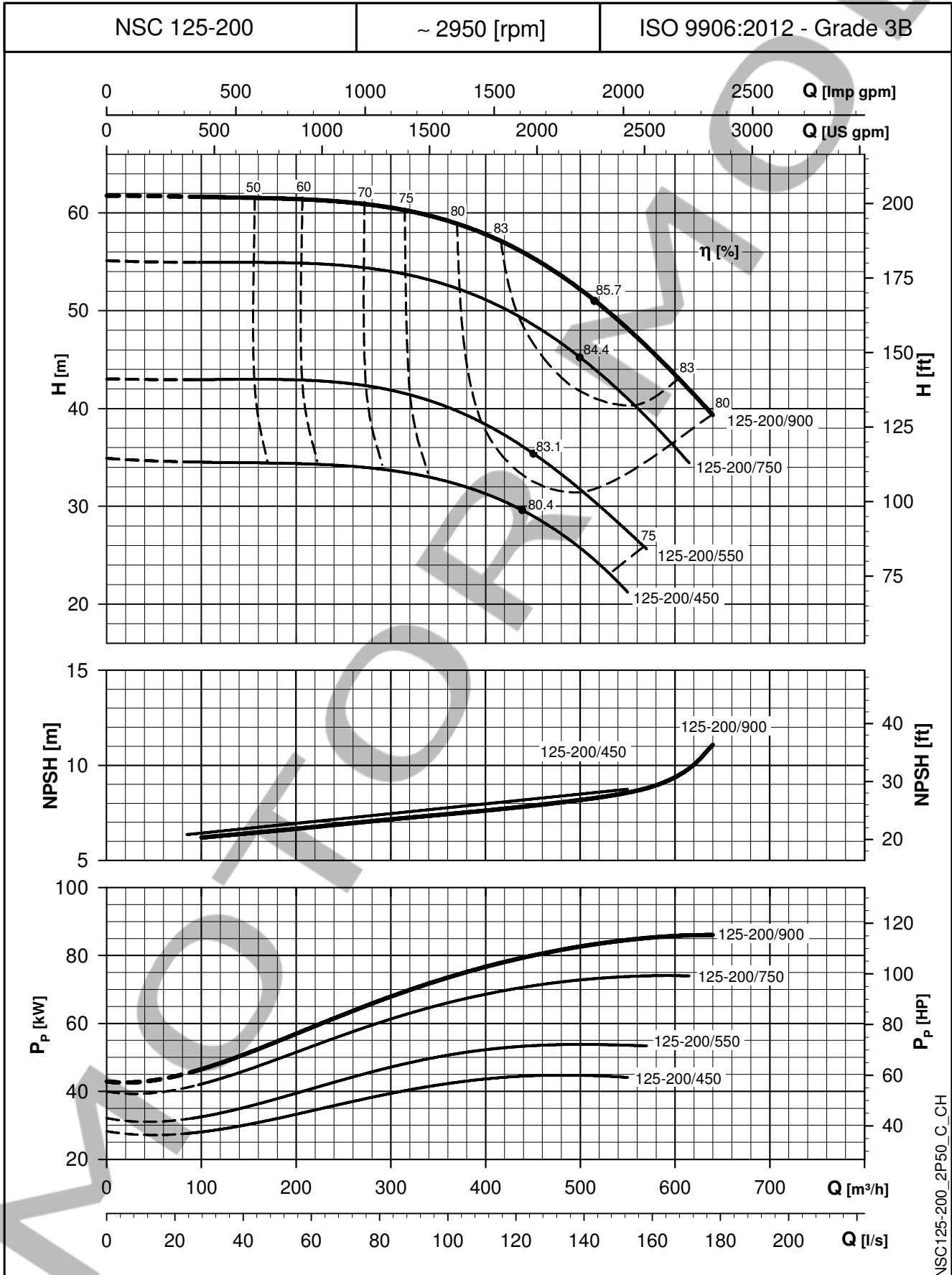

NSC125-200_2P50_C_CH

The NPSH values are laboratory values; for practical use we suggest increasing these values by 0,5 m.
 These performances are valid for liquids with density $\rho = 1,0 \text{ Kg/dm}^3$ and kinematic viscosity $\nu = 1 \text{ mm}^2/\text{sec}$.

e-NSC SERIES

OPERATING CHARACTERISTICS AT 50 Hz, 2 POLES

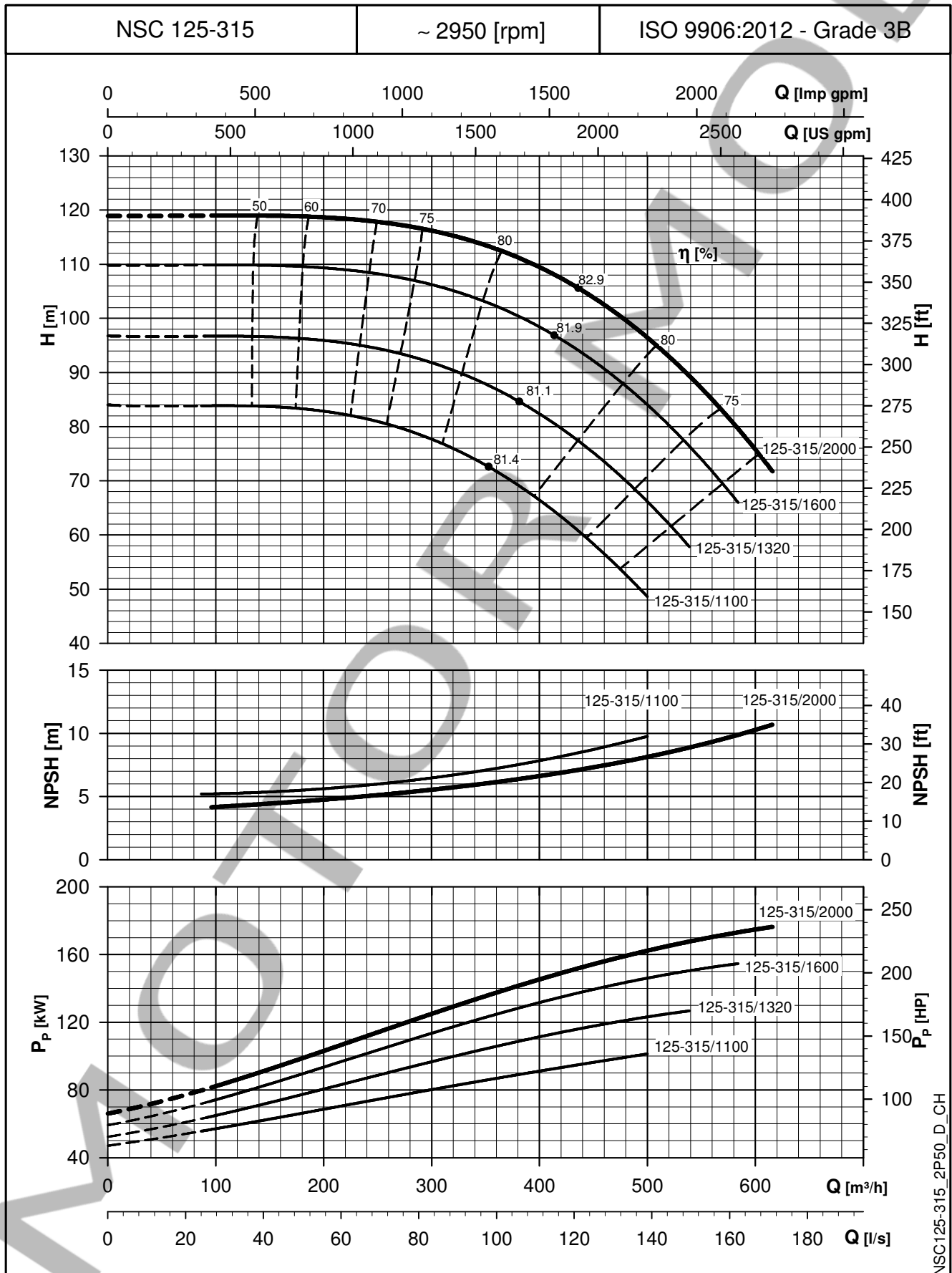

NSC125-315_2P50_D_CH

The NPSH values are laboratory values; for practical use we suggest increasing these values by 0,5 m.
 These performances are valid for liquids with density $\rho = 1,0 \text{ Kg/dm}^3$ and kinematic viscosity $\nu = 1 \text{ mm}^2/\text{sec}$.

**NSCF 80, 100, 125 SERIES (MOUNTED ON BASE)
DIMENSIONS AND WEIGHTS AT 50 Hz, 2 POLES**

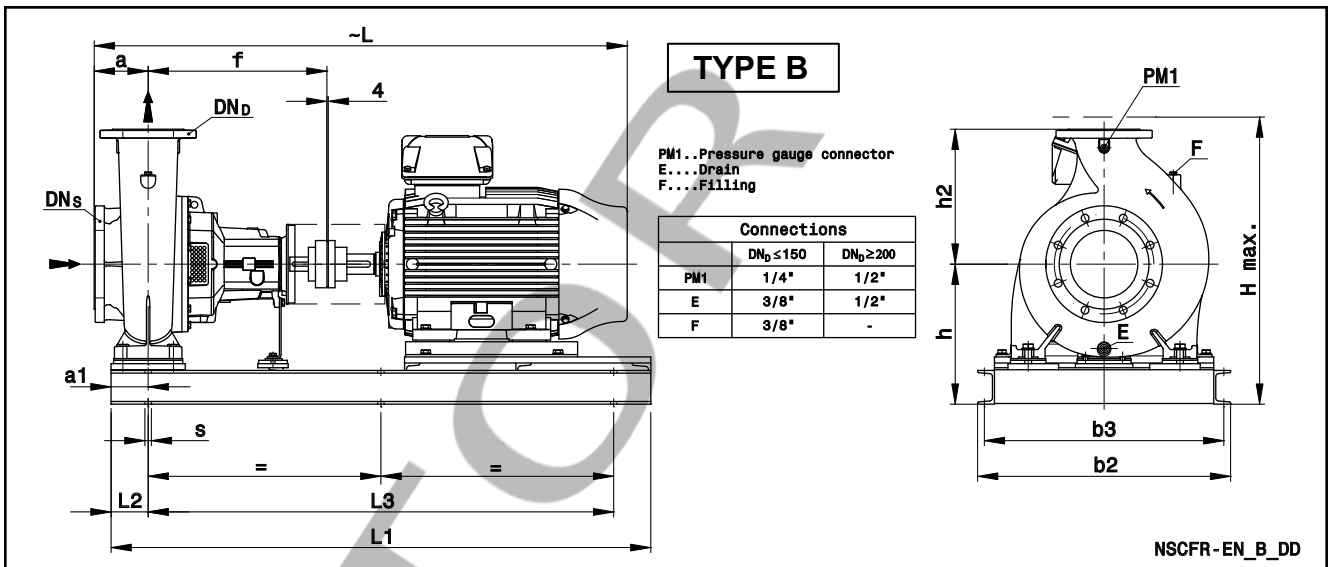
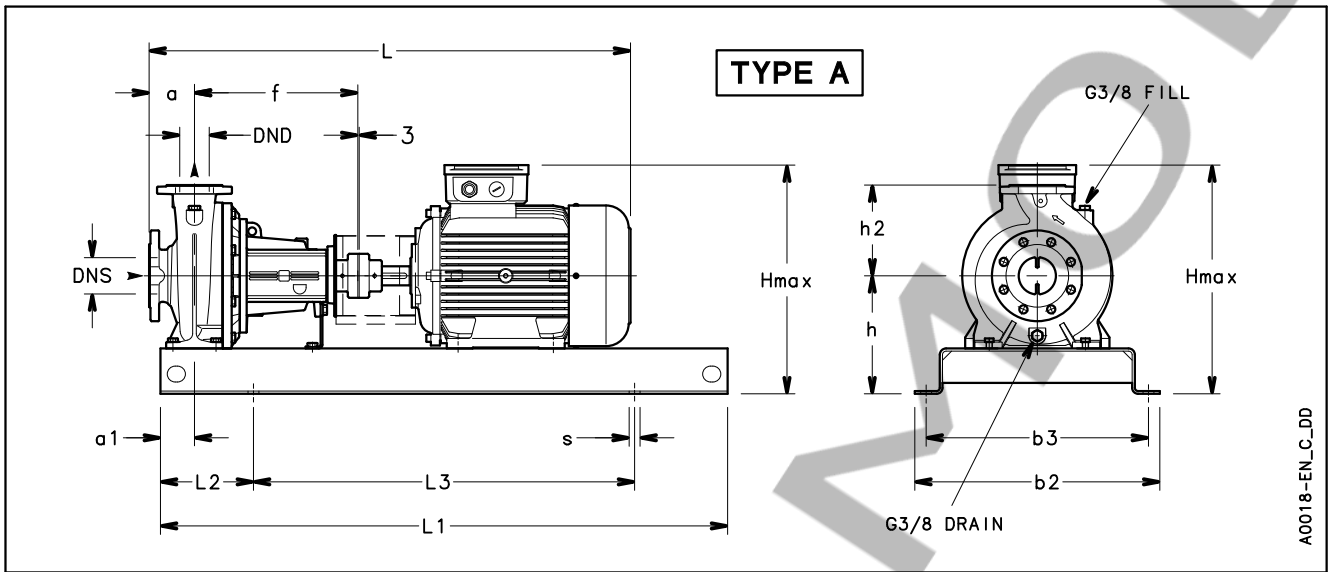

NSCF 80, 100, 125 SERIES (MOUNTED ON BASE) DIMENSIONS AND WEIGHTS AT 50 Hz, 2 POLES

PUMP TYPE NSCF..2	TYPE	DIMENSIONS (mm)														H max	s FOR SCREWS	WEIGHT (kg) G	COUPLING TYPE
		DNS	DND	a	a1	b2	b3	f	h	h2	L	L1	L2	L3					
80-160/110/P	A	100	80	125	75	540	490	360	280	225	1092	1250	205	840	520	4xØ24 (M20)	194	B95B	
80-160/150/P	A	100	80	125	75	540	490	360	280	225	1092	1250	205	840	520	4xØ24 (M20)	211	B95B	
80-160/185/P	A	100	80	125	75	540	490	360	280	225	1092	1250	205	840	520	4xØ24 (M20)	224	B95B	
80-160/220/W	A	100	80	125	75	540	490	360	280	225	1152	1250	205	840	559	4xØ24 (M20)	291	B110A	
80-200/220/W	A	100	80	125	75	540	490	470	280	250	1262	1250	205	840	559	4xØ24 (M20)	308	B110B	
80-200/300/W	A	100	80	125	75	610	550	470	310	250	1365	1400	230	940	627	4xØ28 (M24)	390	B125B	
80-200/370/W	A	100	80	125	75	610	550	470	310	250	1365	1400	230	940	627	4xØ28 (M24)	411	B125B	
80-200/450/W	A	100	80	125	75	610	550	470	365	250	1454	1400	230	940	749	4xØ28 (M24)	562	B125B	
80-250/370/W	A	100	80	125	90	610	550	470	310	280	1365	1400	230	940	627	4xØ28 (M24)	414	B125B	
80-250/450/W	A	100	80	125	90	610	550	470	365	280	1454	1400	230	940	749	4xØ28 (M24)	565	B125B	
80-250/550/W	A	100	80	125	90	660	600	470	390	280	1563	1600	270	1060	792	4xØ28 (M24)	674	B140A	
80-250/750/W	A	100	80	125	90	730	670	470	420	280	1669	1800	300	1200	892	4xØ28 (M24)	942	B160A	
80-316/900/W	B	100	80	125	110	750	710	530	440	315	1730	1600	110	1380	912	6xØ19 (M16)	1061	B160B	
80-316/1100/W	B	100	80	125	110	860	810	530	505	315	1903	1850	110	1630	1035	6xØ26 (M20)	1340	B160B	
80-316/1320/W	B	100	80	125	110	860	810	530	505	315	1903	1850	110	1630	1035	6xØ26 (M20)	1426	B160B	
80-316/1600/W	B	100	80	125	110	860	810	530	505	315	1903	1850	110	1630	1035	6xØ26 (M20)	1507	B160B	
100-160/150/P	B	125	100	125	110	670	630	470	365	280	1203	1330	110	1110	645	6xØ19 (M16)	304	B95E	
100-160/185/P	B	125	100	125	110	670	630	470	365	280	1203	1330	110	1110	645	6xØ19 (M16)	312	B95E	
100-160/220/W	B	125	100	125	110	670	630	470	385	280	1263	1330	110	1110	665	6xØ19 (M16)	385	B110B	
100-160/300/W	B	125	100	125	110	560	520	470	330	280	1366	1350	110	1130	647	6xØ19 (M16)	422	B125B	
100-200/300/W	B	125	100	125	110	560	520	470	330	280	1366	1350	110	1130	647	6xØ19 (M16)	430	B125B	
100-200/370/W	B	125	100	125	110	560	520	470	330	280	1366	1350	110	1130	647	6xØ19 (M16)	451	B125B	
100-200/450/W	B	125	100	125	110	560	520	470	355	280	1455	1350	110	1130	739	6xØ19 (M16)	610	B125B	
100-200/550/W	B	125	100	125	110	750	710	470	405	280	1564	1550	110	1330	807	6xØ19 (M16)	735	B140A	
100-250/450/W	B	125	100	140	110	560	520	470	355	280	1470	1350	110	1130	739	6xØ19 (M16)	612	B125B	
100-250/550/W	B	125	100	140	110	750	710	470	405	280	1579	1550	110	1330	807	6xØ19 (M16)	738	B140A	
100-250/750/W	B	125	100	140	110	750	710	470	390	280	1685	1550	110	1330	862	6xØ19 (M16)	956	B160A	
100-250/900/W	B	125	100	140	110	750	710	470	390	280	1685	1550	110	1330	862	6xØ19 (M16)	991	B160A	
100-316/1100/W	B	125	100	140	110	860	810	530	505	315	1918	1850	110	1630	1035	6xØ26 (M20)	1343	B160B	
100-316/1320/W	B	125	100	140	110	860	810	530	505	315	1918	1850	110	1630	1035	6xØ26 (M20)	1429	B160B	
100-316/1600/W	B	125	100	140	110	860	810	530	505	315	1918	1850	110	1630	1035	6xØ26 (M20)	1510	B160B	
125-200/450/W	B	150	125	140	110	560	520	470	355	315	1470	1350	110	1130	739	6xØ19 (M16)	617	B125B	
125-200/550/W	B	150	125	140	110	750	710	470	405	315	1579	1550	110	1330	807	6xØ19 (M16)	743	B140A	
125-200/750/W	B	150	125	140	110	750	710	470	405	315	1685	1550	110	1330	877	6xØ19 (M16)	970	B160A	
125-200/900/W	B	150	125	140	110	750	710	470	405	315	1685	1550	110	1330	877	6xØ19 (M16)	1005	B160A	
125-315/1100/W	B	150	125	140	110	860	810	530	505	355	1918	1850	110	1630	1035	6xØ26 (M20)	1344	B160B	
125-315/1320/W	B	150	125	140	110	860	810	530	505	355	1918	1850	110	1630	1035	6xØ26 (M20)	1430	B160B	
125-315/1600/W	B	150	125	140	110	860	810	530	505	355	1918	1850	110	1630	1035	6xØ26 (M20)	1511	B160B	
125-315/2000/W	B	150	125	140	110	860	810	530	505	355	2027	1850	110	1630	1080	6xØ26 (M20)	1692	B180A	

NOTE: Pumps with flanges according to EN 1092-2 as standard.

Nscf80-125-2p50-en_c_td

Available ASME B16.5 version on request. For flanges dimensions see drawing.