

50 Hz



e-NSC Series

HORIZONTAL CENTRIFUGAL ELECTRIC PUMPS
EQUIPPED WITH **IE3** MOTORS

ErP 2009/125/EC

Cod. 191002951 Rev. G Ed.07/2017

 **LOWARA**
a xylem brand

e-NSC SERIES
LIST OF MODELS AT 50 Hz, 2 POLES

SIZE NSC	kW	VERSION			
		NSCE	NSCS	NSCF	NSCC
100-160/150	15	-	•	•	•
100-160/185	18,5	-	•	•	•
100-160/220	22	-	•	•	•
100-160/300	30	-	•	•	•
100-200/300	30	-	•	•	•
100-200/370	37	-	•	•	•
100-200/450	45	-	•	•	•
100-200/550	55	-	•	•	•
100-250/450	45	-	-	•	•
100-250/550	55	-	-	•	•
100-250/750	75	-	•	•	•
100-250/900	90	-	•	•	•
100-316/1100	110	-	-	•	•
100-316/1320	132	-	-	•	•
100-316/1600	160	-	-	•	•
125-200/450	45	-	•	•	•
125-200/550	55	-	•	•	•
125-200/750	75	-	•	•	•
125-200/900	90	-	•	•	•
125-315/1100	110	-	-	•	•
125-315/1320	132	-	-	•	•
125-315/1600	160	-	-	•	•
125-315/2000	200	-	-	•	•

• = Available

Nsc2_models-2p50-en_b_sc

e-NSC 100-125-150 SERIES HYDRAULIC PERFORMANCE RANGE AT 50 Hz, 4 POLES

PUMP TYPE	P _N kW	Ø Impeller (mm)				Q = DELIVERY												
		STD	B	●	η _p %	l/s	5.6	12.6	19.7	26.8	33.8	40.9	48.0	55.1	62.1	69.2	76.3	83.3
						m ³ /h	0	20	45	71	96	122	147	173	198	224	249	275
H = TOTAL HEAD METRES COLUMN OF WATER																		
100-160/22A	2.2	144	144	○	75.9	5.9		5.9	5.6	4.9	3.7							
100-160/22	2.2	156	156	○	77.4	6.9		6.9	6.6	6.0	4.8	3.5						
100-160/30	3	176	176	○	81.5	9.1		9.0	8.8	8.1	7.0	5.6	4.0					
100-160/40	4	190	190	●	83.6	10.8		10.6	10.4	9.8	8.9	7.6	6.0					
100-200/40	4.0	197	197	○	82.6	12.2		12.1	11.8	11.0	9.6	7.5	5.1					
100-200/55	5.5	213	213	○	83.8	14.8		14.6	14.5	13.8	12.6	10.7	8.4					
100-200/75	7.5	227	227	●	84.3	16.9		16.7	16.5	15.9	14.8	13.1	11.0	8.4				
100-250/55	5.5	213	213	○	80.6	14.1		14.1	13.8	13.1	11.9	10.1	8.0					
100-250/75	7.5	237	237	○	83.1	17.8		17.9	17.7	17.2	16.2	14.6	12.5	10.1				
100-250/110	11	259	259	●	84.1	21.9		21.9	21.7	21.1	20.0	18.4	16.3	13.8				
100-315/110	11	260	260	○	78.9	23.5	23.5	23.4	23.1	22.4	21.1	19.2	16.5	12.6				
100-315/150	15	284	284	○	79.5	28.0		28.0	27.8	27.2	26.0	24.4	22.4	19.5				
100-315/185	18.5	298	298	○	79.9	31.1		31.0	30.9	30.3	29.3	27.8	26.1	23.8	20.4			
100-315/220	22	312	312	○	80.6	34.3		34.2	34.1	33.7	32.8	31.4	29.6	27.6	25.0			
100-315/300	30	334	334	●	80.8	40.2		40.1	40.1	39.7	38.8	37.6	36.0	34.0	31.5	28.2		
100-400/300	30	375	375	○	76.8	47.4		46.5	45.8	44.9	43.7	42.1	40.0	37.4	34.3	30.6		
100-400/370	37	397	397	○	77.1	54.4		53.3	52.5	51.6	50.4	48.9	47.1	44.8	42.0	38.6	34.7	
100-400/450	45	420	420	●	76.9	61.3		60.0	59.4	58.6	57.3	55.7	53.8	51.6	49.0	45.8	42.0	37.3

PUMP TYPE	P _N kW	Ø Impeller (mm)				Q = DELIVERY												
		STD	B	●	η _p %	l/s	11.9	21.4	30.9	40.5	50.0	59.5	69.0	78.6	88.1	97.6	107.1	116.7
						m ³ /h	0	43	77	111	146	180	214	249	283	317	351	386
H = TOTAL HEAD METRES COLUMN OF WATER																		
125-200/55	5.5	179	179	○	80.9	8.6		8.4	8.4	8.3	8.0	7.2	6.0					
125-200/75	7.5	204	204	○	83.5	11.9		11.8	11.8	11.6	11.2	10.3	9.0	7.5				
125-200/110	11	225	225	●	85.4	15.0		14.9	14.9	14.8	14.4	13.7	12.6	11.1	9.3			
125-250/75	7.5	210	210	○	84.5	13.6	13.5	13.4	13.3	12.9	12.1	10.6	8.6	6.3				
125-250/110	11	235	235	○	86.3	17.5		17.4	17.4	17.2	16.6	15.3	13.5	11.3	9.2			
125-250/150	15	259	259	●	88.3	22.0		21.7	21.7	21.5	21.0	20.0	18.5	16.5	14.1	11.6		
125-315/185	18.5	277	277	○	83.7	25.6		25.7	25.6	25.3	24.4	22.8	20.1	16.4	11.9	7.3		
125-315/220	22	290	290	○	84.3	28.3		28.6	28.5	28.2	27.5	26.1	23.8	20.7	16.6			
125-315/300	30	315	315	○	85.4	34.8		35.1	35.0	34.8	34.1	33.0	31.4	29.1	26.0	22.1		
125-315/370	37	334	334	●	86.4	39.6		39.8	39.9	39.7	39.2	38.2	36.8	34.8	32.1	28.7	24.6	
125-400/370	37	353	353	○	78.0	43.4		43.9	43.8	43.2	41.9	39.9	37.0	33.0	28.0			
125-400/450	45	374	374	○	78.8	48.7		49.4	49.6	49.3	48.3	46.4	43.7	40.0	35.4	30.0		
125-400/550	55	394	394	○	79.1	54.4		55.6	55.8	55.5	54.6	53.0	50.7	47.6	43.6	38.7		
125-400/750	75	422	422	●	79.9	63.4		64.8	64.7	64.2	63.3	61.8	59.8	57.1	53.8	49.8	45.0	39.3

PUMP TYPE	P _N kW	Ø Impeller (mm)				Q = DELIVERY												
		STD	B	●	η _p %	l/s	16.7	33.8	51.0	68.2	85.4	102.5	119.7	136.9	154.0	171.2	188.4	205.6
						m ³ /h	0	60	122	184	245	307	369	431	493	555	616	678
H = TOTAL HEAD METRES COLUMN OF WATER																		
150-200/110A	11	200	200	○	78.8	11.8		11.3	10.5	9.4	8.3	7.0	5.4					
150-200/110	11	217	217	○	80.7	14.0		13.4	12.5	11.4	10.1	8.7	7.0	4.9				
150-200/150A	15	227	227	○	82.0	15.2		14.5	13.8	12.9	11.7	10.2	8.4	6.4				
150-200/150	15	237	237	●	83.9	16.3		15.6	15.1	14.4	13.4	12.0	10.3	8.2				
150-250/150	15	238	238	○	80.3	17.2	17.0	16.7	16.1	15.1	13.7	11.6	9.1					
150-250/185	18.5	253	253	○	82.7	19.8		19.1	18.7	17.9	16.6	14.8	12.4	9.5				
150-250/220	22	265	265	○	84.6	22.1		21.4	21.0	20.4	19.3	17.6	15.4	12.6				
150-250/300	30	282	282	●	86.2	26.4		25.3	24.7	23.9	22.9	21.5	19.6	17.3	14.4			
150-315/300	30	291	291	○	84.2	27.7		27.7	27.6	27.0	25.7	23.5	20.4	16.5				
150-315/370	37	310	310	○	85.1	31.9		31.8	31.6	31.1	30.0	28.1	25.3	21.5	17.1			
150-315/450	45	330	330	●	86.3	36.6		36.2	36.1	35.7	34.7	32.9	30.4	27.2	23.2			
150-400/450	45	327	327	○	81.8	36.7		36.9	36.6	35.6	34.0	31.7	28.6	24.6				
150-400/550	55	346	346	○	84.4	41.2		41.6	41.5	40.9	39.5	37.5	34.6	30.9	26.3			
150-400/750	75	377	377	○	84.9	50.3		50.8	50.9	50.4	49.1	47.0	44.4	41.3	37.7	33.3		
150-400/900	90	398	398	○	85.3	56.5		56.9	57.0	56.5	55.5	53.7	51.4	48.5	45.1	41.0		
150-400/1100	110	423	423	●	85.5	63.9		64.4	64.3	63.9	63.0	61.5	59.4	56.6	53.2	49.1	44.4	
150-500/900	90	420	420	○	75.1	60.9		61.6	61.8	61.1	59.0	55.2	49.6	42.6	34.5			
150-500/1100	110	443	443	○	75.4	68.5		68.9	69.3	69.0	67.5	64.4	59.5	52.7	44.6	36.1		
150-500/1320	132	467	467	○	76.5	76.9		77.6	78.1	78.0	76.9	74.3	70.1	64.0	56.3	47.3		
150-500/1600	160	495	495	○	77.9	87.0		87.9	88.4	88.5	87.8	86.0	82.7	77.6	70.7	62.1	52.6	
150-500/2000	200	516	516	●	78.6	95.1		95.9	96.5	96.7	96.1	94.4	91.4	86.7	80.4	72.6	63.5	53.7

Hydraulic performances in compliance with ISO 9906:2012 - Grade 3B (ex ISO 9906:1999 - Annex A)

Nsc-100-150_4p50-en_c_th

(1) STD = Cast iron/Stainless steel - B = Bronze (2) ● = Full impeller diameter - ○ = Trimmed impeller diameter (3) Hydraulic efficiency of pump.

e-NSC SERIES

OPERATING CHARACTERISTICS AT 50 Hz, 4 POLES

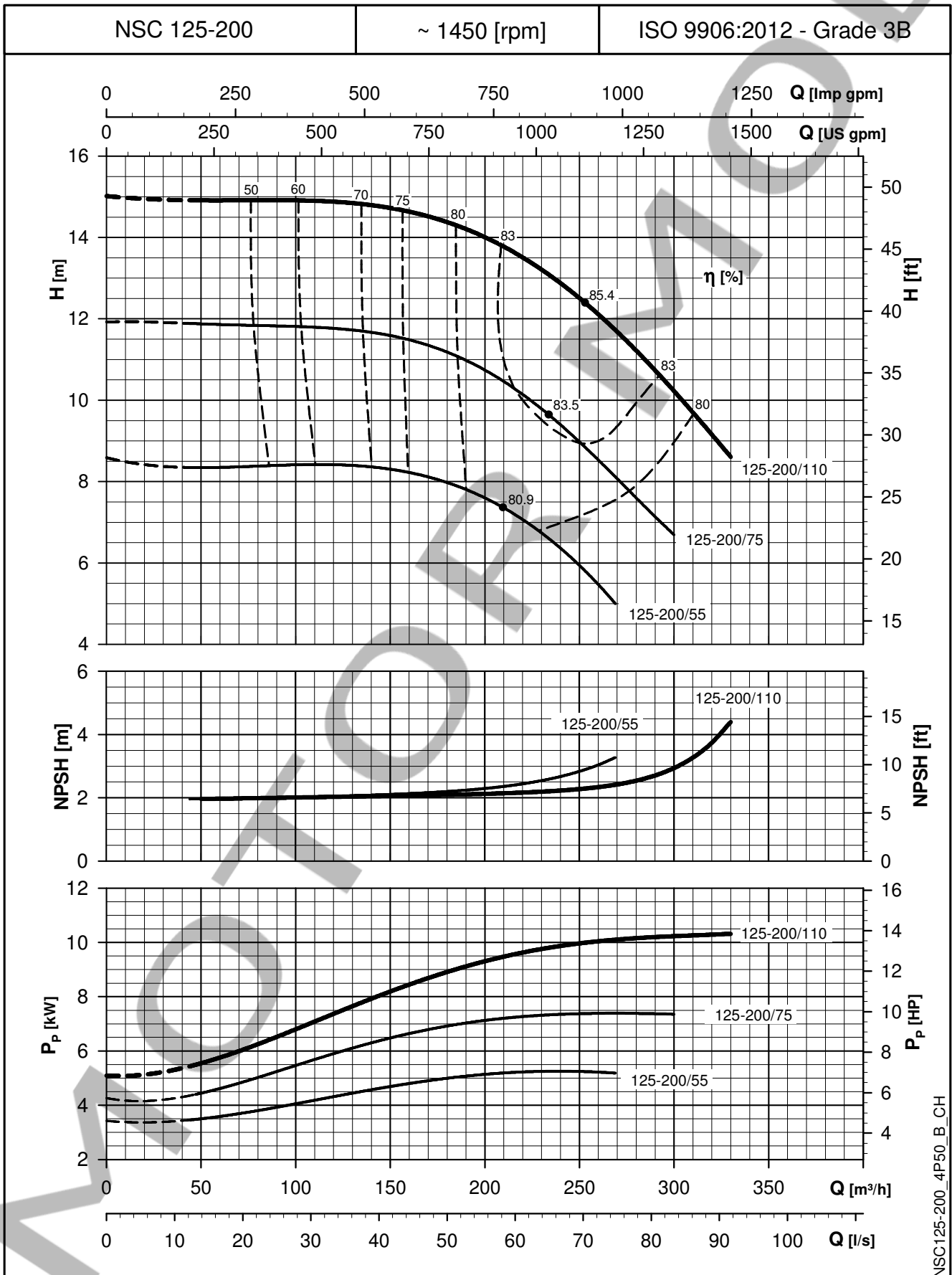

NSC125-200_4P50_B_CH

The NPSH values are laboratory values; for practical use we suggest increasing these values by 0,5 m.
 These performances are valid for liquids with density $\rho = 1,0 \text{ Kg/dm}^3$ and kinematic viscosity $\nu = 1 \text{ mm}^2/\text{sec}$.

e-NSC SERIES

OPERATING CHARACTERISTICS AT 50 Hz, 4 POLES

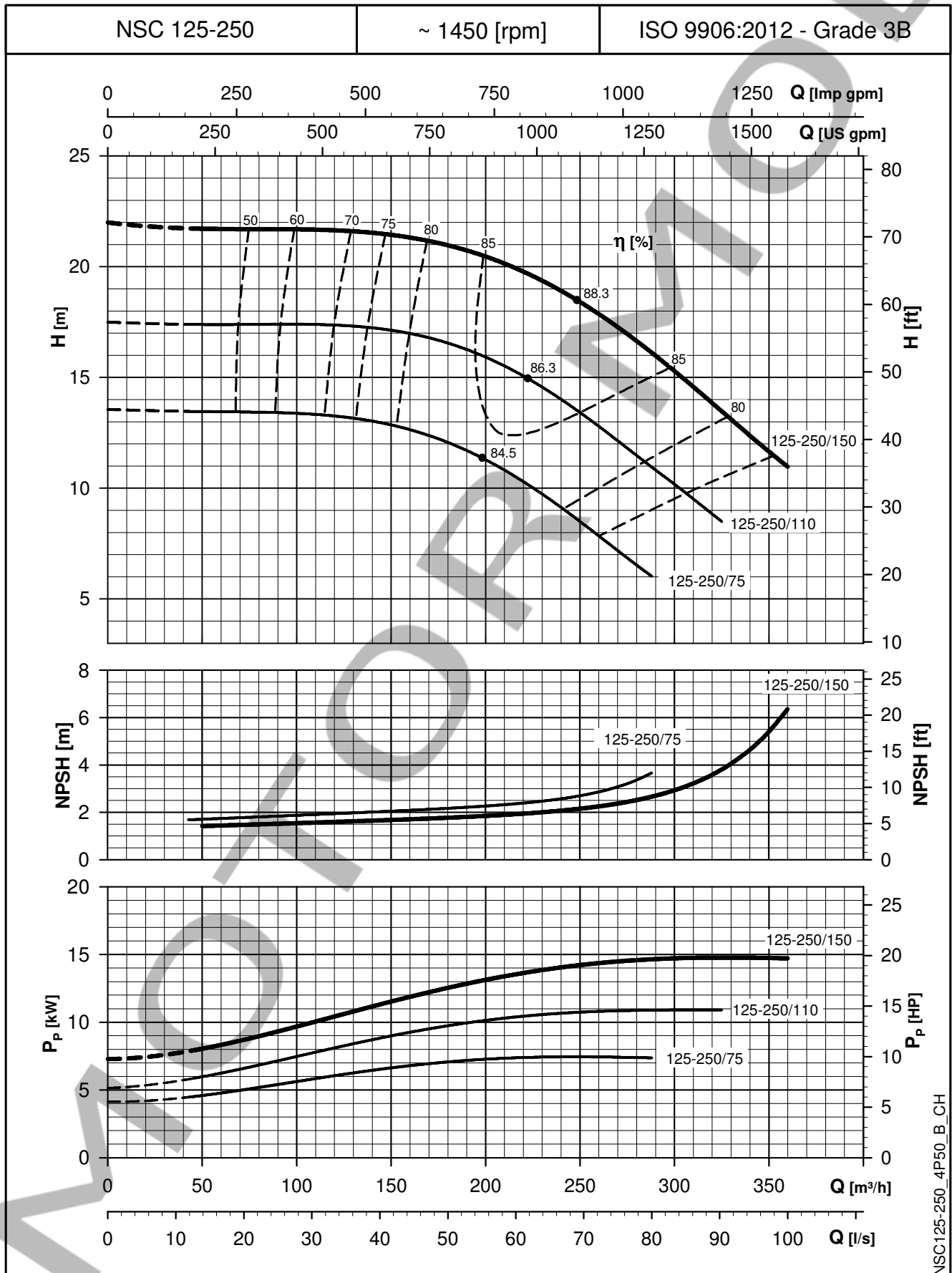

NSC125-250_4P50_B_CH

The NPSH values are laboratory values; for practical use we suggest increasing these values by 0,5 m.
 These performances are valid for liquids with density $\rho = 1,0 \text{ Kg/dm}^3$ and kinematic viscosity $\nu = 1 \text{ mm}^2/\text{sec}$.

e-NSC SERIES

OPERATING CHARACTERISTICS AT 50 Hz, 4 POLES

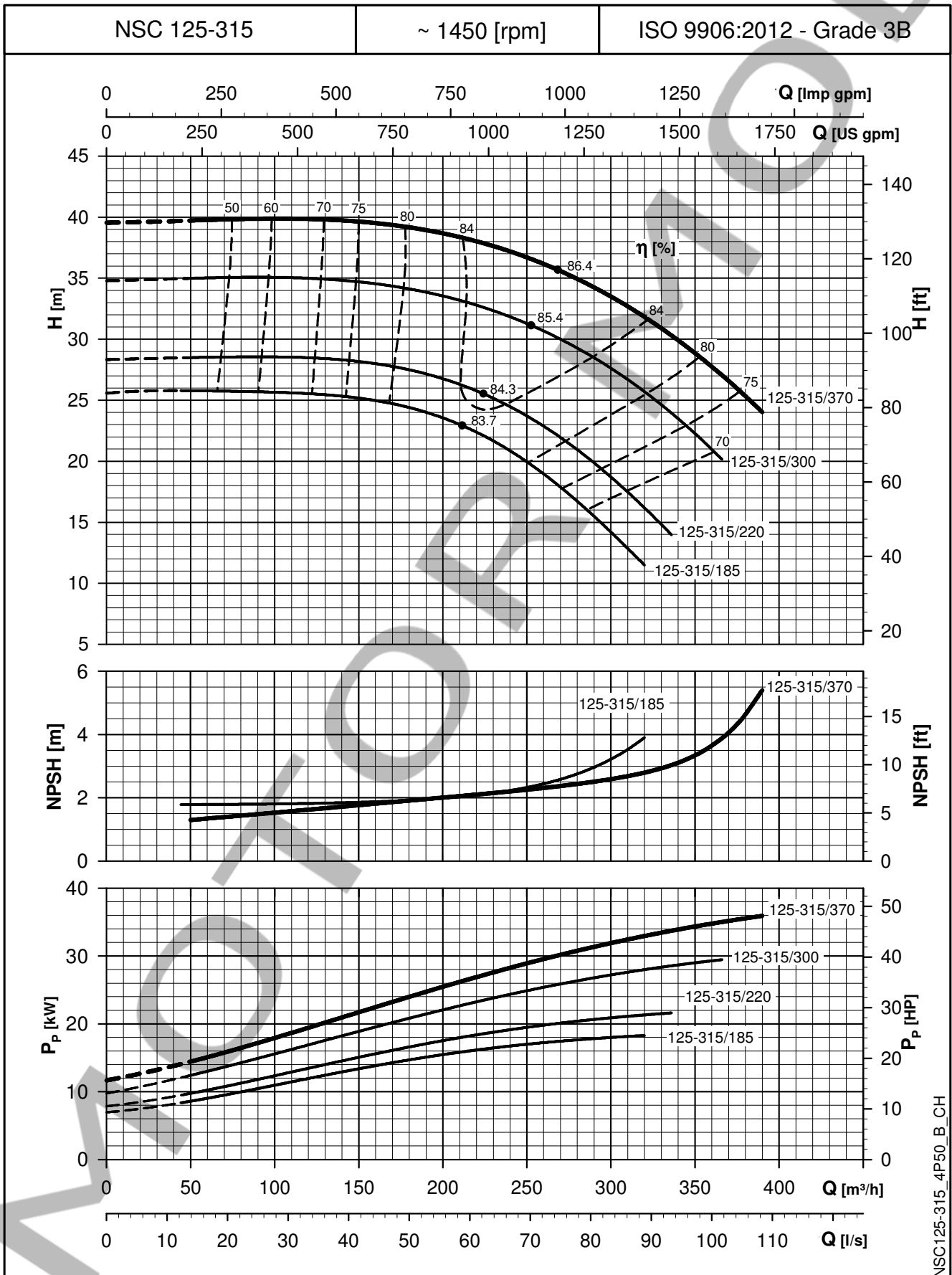

NSC125-315_4P50_B_CH

The NPSH values are laboratory values; for practical use we suggest increasing these values by 0,5 m.
 These performances are valid for liquids with density $\rho = 1,0 \text{ Kg/dm}^3$ and kinematic viscosity $\nu = 1 \text{ mm}^2/\text{sec}$.

**NSC 100, 125, 150, 200, 250, 300 SERIES
DIMENSIONS AND WEIGHTS (BARE SHAFT)**

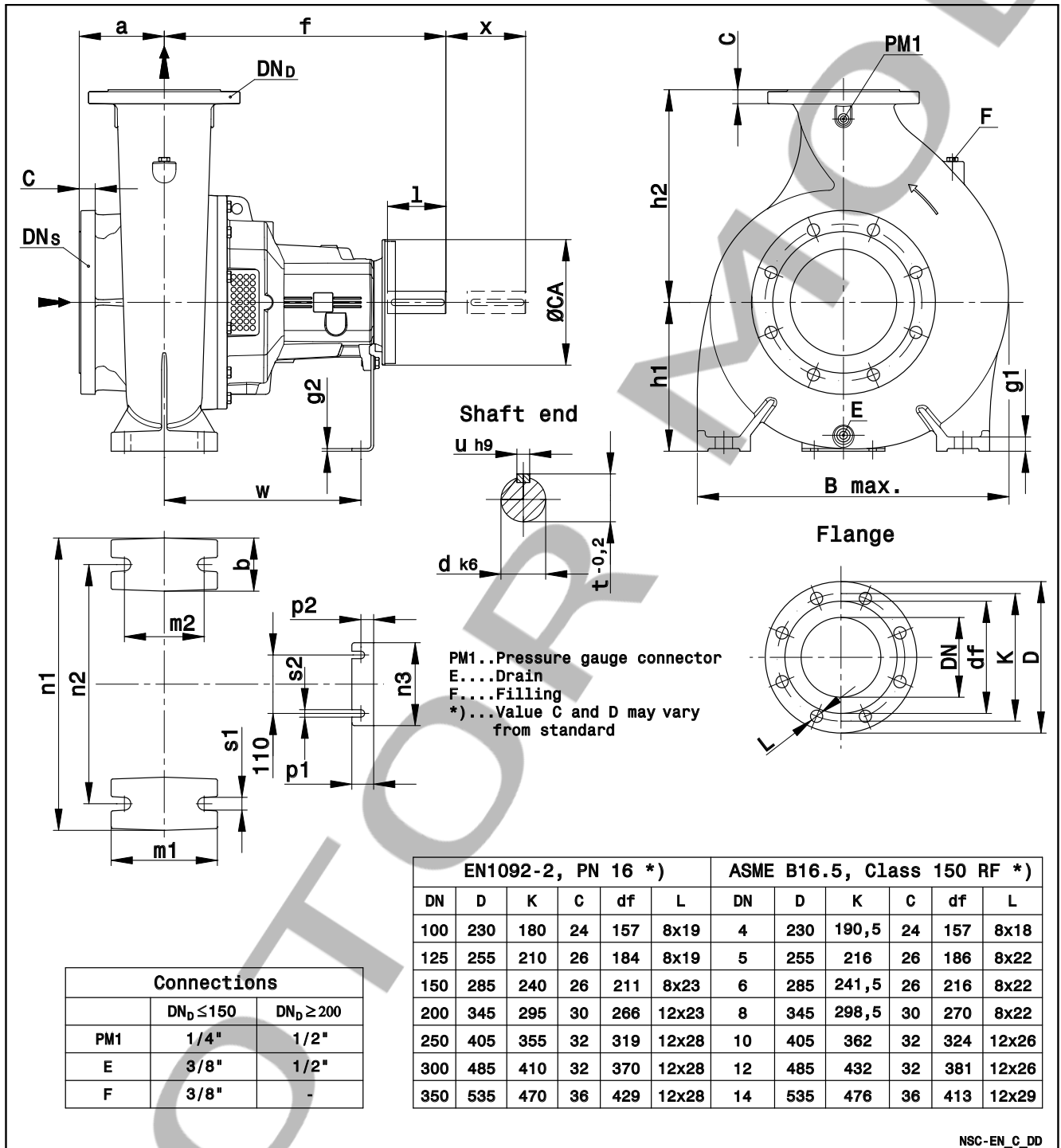

NSC 100, 125, 150, 200, 250, 300 SERIES DIMENSIONS AND WEIGHTS (BARE SHAFT)

PUMP TYPE NSC (BARE SHAFT)	DIMENSIONS (mm)																												WEIGHT (kg) G
	DNS	DND	a	b	f	g1	g2	h1	h2	m1	m2	n1	n2	n3	p1	p2	s1	s2	W	ØCA	d	l	t	u	B max	x			
100-160	125	100	125	80	470	26	5	200	280	160	120	360	280	156	41	24	19	14	340	190	32	80	35	10	388	140	82		
100-200	125	100	125	80	470	26	5	200	280	160	120	360	280	156	41	24	19	14	340	190	32	80	35	10	390	140	90		
100-250	125	100	140	80	470	26	5	225	280	160	120	400	315	156	41	24	19	14	340	190	32	80	35	10	431	140	100		
100-315	125	100	140	80	470	26	5	250	315	160	120	400	315	156	41	24	19	14	340	190	32	80	35	10	482	140	116		
100-316	125	100	140	80	530	26	5	250	315	160	120	400	315	156	41	24	19	14	370	230	42	110	45	12	482	140	143		
100-400	125	100	140	100	530	26	5	280	355	200	150	500	400	156	41	24	23	14	370	230	42	110	45	12	569	140	178		
125-200	150	125	140	80	470	26	5	250	315	160	120	400	315	156	41	24	19	14	340	190	32	80	35	10	468	140	112		
125-250	150	125	140	80	470	26	5	250	355	160	120	400	315	156	41	24	19	14	340	190	32	80	35	10	470	140	112		
125-315	150	125	140	100	530	26	5	280	355	200	150	500	400	156	41	24	23	14	370	230	42	110	45	12	518	140	152		
125-400	150	125	140	100	530	26	5	315	400	200	150	500	400	156	41	24	23	14	370	230	42	110	45	12	607	140	200		
150-200	200	150	160	100	470	26	5	280	400	200	150	550	450	156	41	24	23	14	340	190	32	80	35	10	603	140	166		
150-250	200	150	160	100	530	26	5	280	400	200	150	500	400	156	41	24	23	14	370	230	42	110	45	12	569	140	180		
150-315	200	150	160	100	530	26	5	280	400	200	150	550	450	156	41	24	23	14	370	230	42	110	45	12	586	140	186		
150-400	200	150	160	100	530	26	5	315	450	200	150	550	450	156	41	24	23	14	370	230	42	110	45	12	621	140	228		
150-500	200	150	180	110	770	35	8	400	500	300	250	710	600	170	58	33	28	18	525	310	60	140	64	18	751	250	408		
200-250	250	200	180	100	530	26	5	355	475	200	150	550	450	156	41	24	23	14	370	230	42	110	45	12	655	200	230		
200-315	250	200	180	100	530	26	5	355	450	200	150	550	450	156	41	24	23	14	370	230	42	110	45	12	645	200	234		
200-400	250	200	180	110	770	35	8	400	500	300	250	710	600	170	58	33	28	18	525	310	60	140	64	18	735	250	363		
200-500	250	200	200	110	770	35	8	450	560	300	250	710	600	170	58	33	28	18	525	310	60	140	64	18	761	250	400		
250-315	300	250	250	110	530	35	5	400	500	300	250	710	600	156	41	24	28	14	370	230	42	110	45	12	767	200	316		
250-400	300	250	200	110	770	35	8	400	560	300	250	710	600	170	58	33	28	18	525	310	60	140	64	18	754	250	400		
250-500	300	250	200	110	770	35	8	450	670	300	250	710	600	170	58	33	28	18	525	310	60	140	64	18	776	250	451		
300-350	350	300	250	130	800	41	8	450	600	350	290	800	670	170	58	33	32	18	555	310	60	140	64	18	895	300	544		
300-400	350	300	250	130	800	41	8	450	600	350	290	800	670	170	58	33	32	18	555	310	60	140	64	18	854	300	548		
300-450	350	300	250	130	800	41	8	475	630	350	290	800	670	170	58	33	32	18	555	310	60	140	64	18	873	300	578		

NOTE: Pumps with flanges according to EN 1092-2 as standard; available ASME B16.5 version on request.

Nsc100-300bs-en_b_td

e-NSC SERIES

OPERATING CHARACTERISTICS AT 50 Hz, 4 POLES

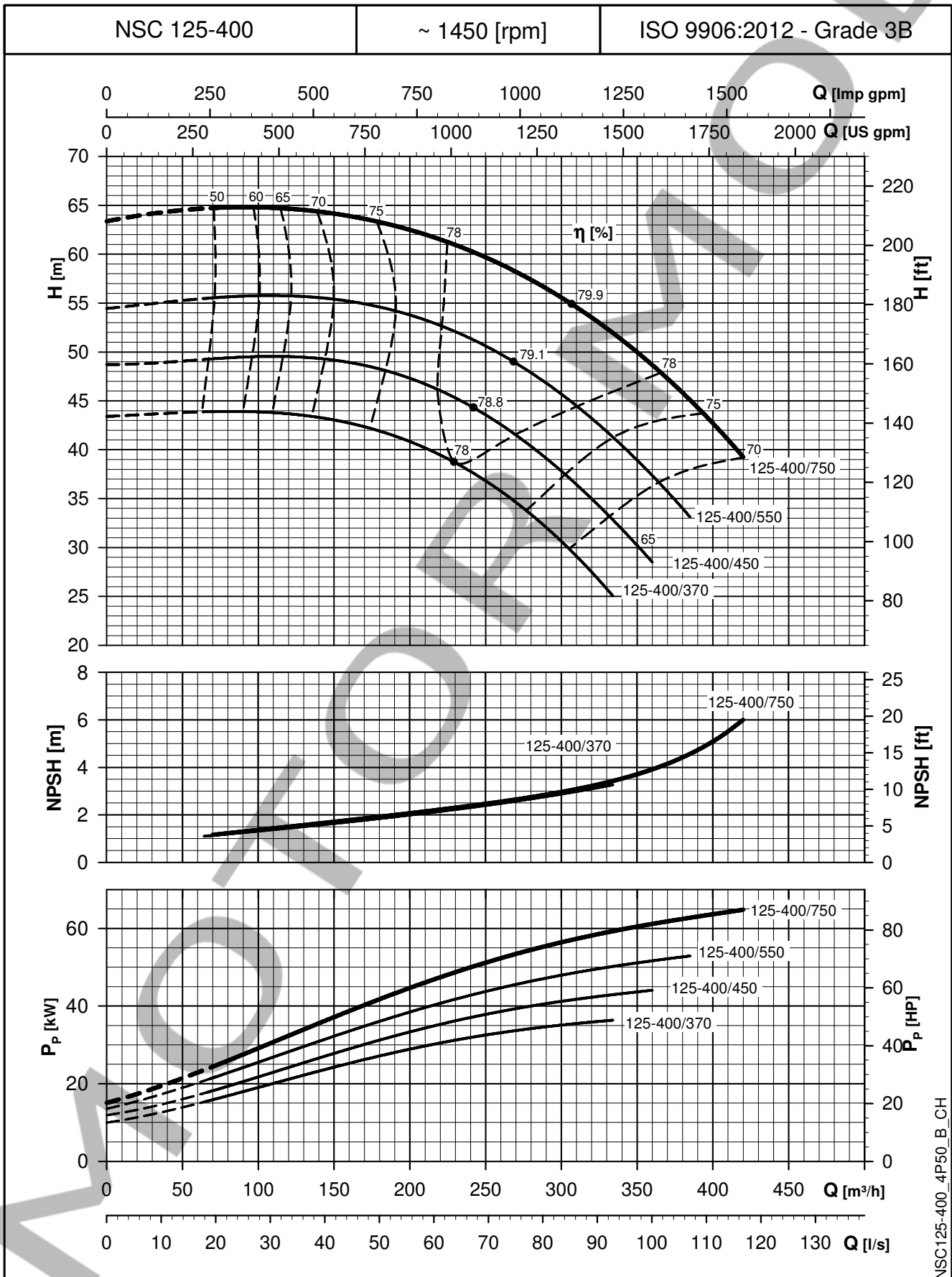

NSC125-400_4P50_B_CH

The NPSH values are laboratory values; for practical use we suggest increasing these values by 0,5 m.
 These performances are valid for liquids with density $\rho = 1,0 \text{ Kg/dm}^3$ and kinematic viscosity $\nu = 1 \text{ mm}^2/\text{sec}$.