

50 Hz



e-SH Series

HORIZONTAL CENTRIFUGAL ELECTRIC PUMPS ACCORDING TO EN 733
MADE IN AISI 316 STAINLESS STEEL AND EQUIPPED WITH **IE3** MOTORS

ErP 2009/125/EC

Cod. 191002961 Rev. C Ed.07/2016

 **LOWARA**
a xylem brand

ESH 65, 80 SERIES

HYDRAULIC PERFORMANCE TABLE AT 50 Hz, 2 POLES

PUMP TYPE	P _N kW	Ø Impeller (mm)			Q = DELIVERY												
		○ ● (1)	η _p % (2)	l/s	8,1	10,6	13,3	15,8	18,3	21,1	23,6	26,4	28,9	31,4	34,2	36,7	
				m ³ /h	0	29	38	48	57	66	76	85	95	104	113	123	132
H = TOTAL HEAD METRES COLUMN OF WATER																	
65-160/40	4	127	○	71,0	19,1	18,7	17,8	16,5	14,9	13,0	10,9	8,6	6,4				
65-160/55	5,5	140	○	75,1	24,6		23,4	22,2	20,8	19,1	17,2	15,1	12,7	10,1	7,4		
65-160/75	7,5	154	○	74,7	30,7			28,4	26,7	24,9	22,9	20,8	18,5	16,0	13,2		
65-160/92	9,2	164	○	77,6	35,7			33,8	32,5	30,9	28,9	26,5	23,8	20,8	17,5		
65-160/110A	11	164	○	77,6	35,7			33,8	32,5	30,9	28,9	26,5	23,8	20,8	17,5		
65-160/110	11	176	●	76,0	41,6				38,5	36,8	34,6	32,1	29,4	26,6			
65-200/150	15	192	○	70,0	53,6			50,0	48,1	45,9	43,2	40,3	37,0	33,4	29,7		
65-200/185	18,5	203	○	71,5	60,7				55,8	53,7	51,2	48,4	45,2	41,8	38,2		
65-200/220	22	210	●	71,5	63,9				60,4	58,6	56,4	53,9	51,0	47,8	44,3	40,7	
65-250/300	30	240	○	74,5	83,7					80,7	78,8	76,5	73,8	70,7	67,0	62,9	
65-250/370	37	255	●	73,5	96,5					93,8	91,8	89,4	86,7	83,6	80,1	76,3	

PUMP TYPE	P _N kW	Ø Impeller (mm)			Q = DELIVERY												
		○ ● (1)	η _p % (2)	l/s	20,0	24,2	28,6	32,8	36,9	41,1	45,6	49,7	53,9	58,1	62,5	66,7	
				m ³ /h	0	72	87	103	118	133	148	164	179	194	209	225	240
H = TOTAL HEAD METRES COLUMN OF WATER																	
80-160/110	11	169x15°	○	75,0	34,0	31,7	30,3	28,4	26,2	23,6	20,7	17,7	14,6	11,6			
80-160/150	15	177	○	76,5	40,8	38,6	37,2	35,4	33,3	30,7	27,9	24,9	21,7	18,4	15,3		
80-160/185	18,5	186	●	78,0	47,8	45,4	44,1	42,4	40,3	38,0	35,3	32,4	29,3	26,0	22,6		
80-200/220	22	198	○	80,5	53,5	51,2	49,9	48,2	46,2	43,9	41,3	38,4	35,3	32,0	28,7		
80-200/300	30	215	○	81,0	64,0	62,4	61,2	59,7	57,7	55,4	52,7	49,7	46,5	43,0	39,5	36,1	
80-200/370	37	226	●	81,5	71,7	70,5	69,5	68,2	66,5	64,3	61,8	59,0	55,8	52,4	48,8	45,1	
80-250/450	45	237	○	79,5	83,9			78,8	76,5	73,8	70,6	66,9	62,9	58,5	53,8		
80-250/550	55	252	○	80,0	95,9			91,8	89,7	87,2	84,2	80,8	76,9	72,8	68,5		
80-250/750	75	270	●	78,0	112,2			108,4	106,5	104,1	101,2	98,0	94,3	90,2	85,9	81,4	

Hydraulic performances in compliance with ISO 9906:2012 - Grade 3B (ex ISO 9906:1999 - Annex A)

ESH-65-80_2p50-en_c_th

(1) ● = Full impeller diameter - ○ = Trimmed impeller diameter (2) Hydraulic efficiency of pump.

ESH SERIES OPERATING CHARACTERISTICS AT 50 Hz, 2 POLES

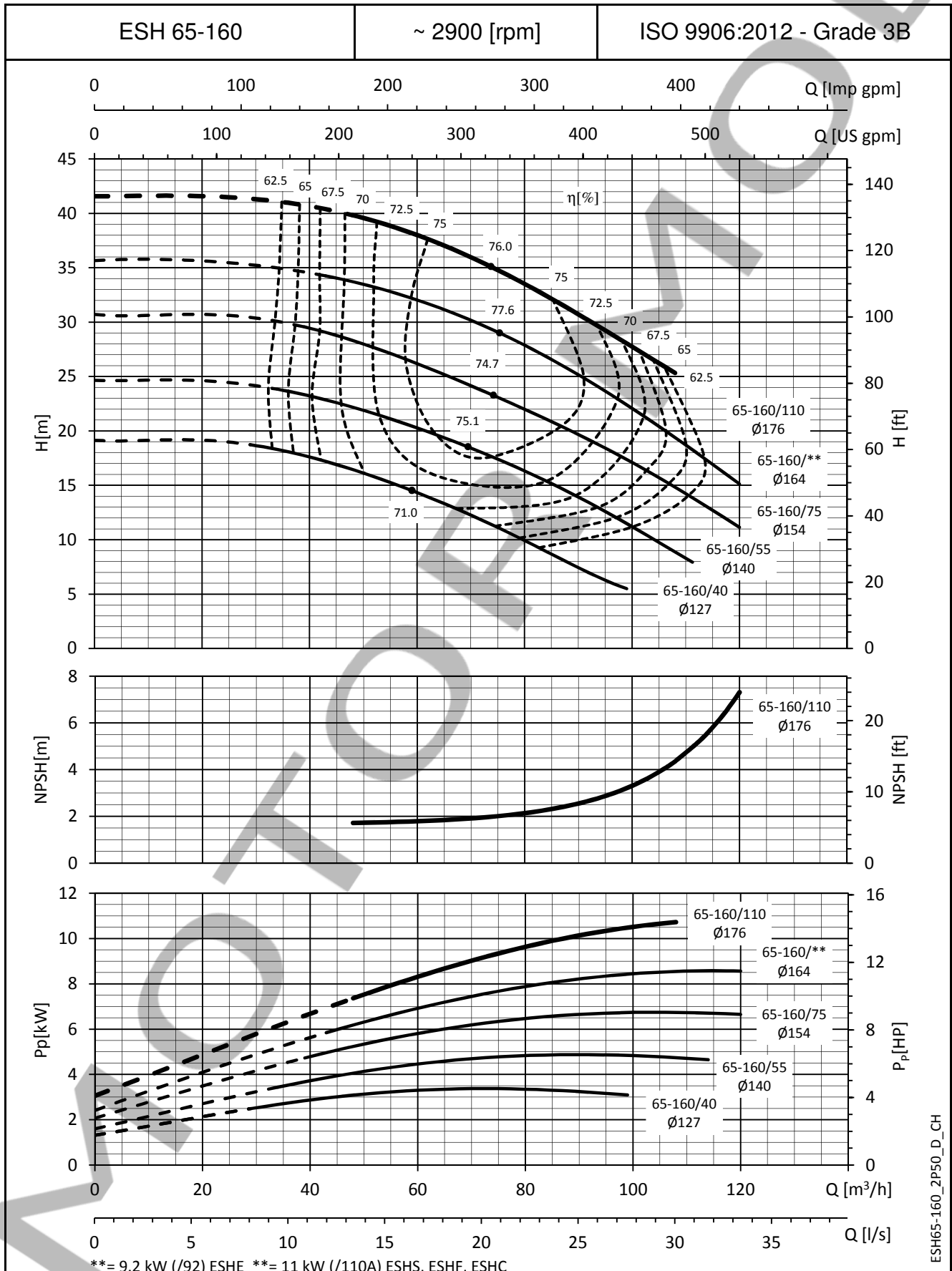

ESH65-160_2P50_D_CH

The NPSH values are laboratory values; for practical use we suggest increasing these values by 0,5 m.
 These performances are valid for liquids with density $\rho = 1,0 \text{ Kg/dm}^3$ and kinematic viscosity $\nu = 1 \text{ mm}^2/\text{sec}$.

ESH SERIES
OPERATING CHARACTERISTICS AT 50 Hz, 2 POLES

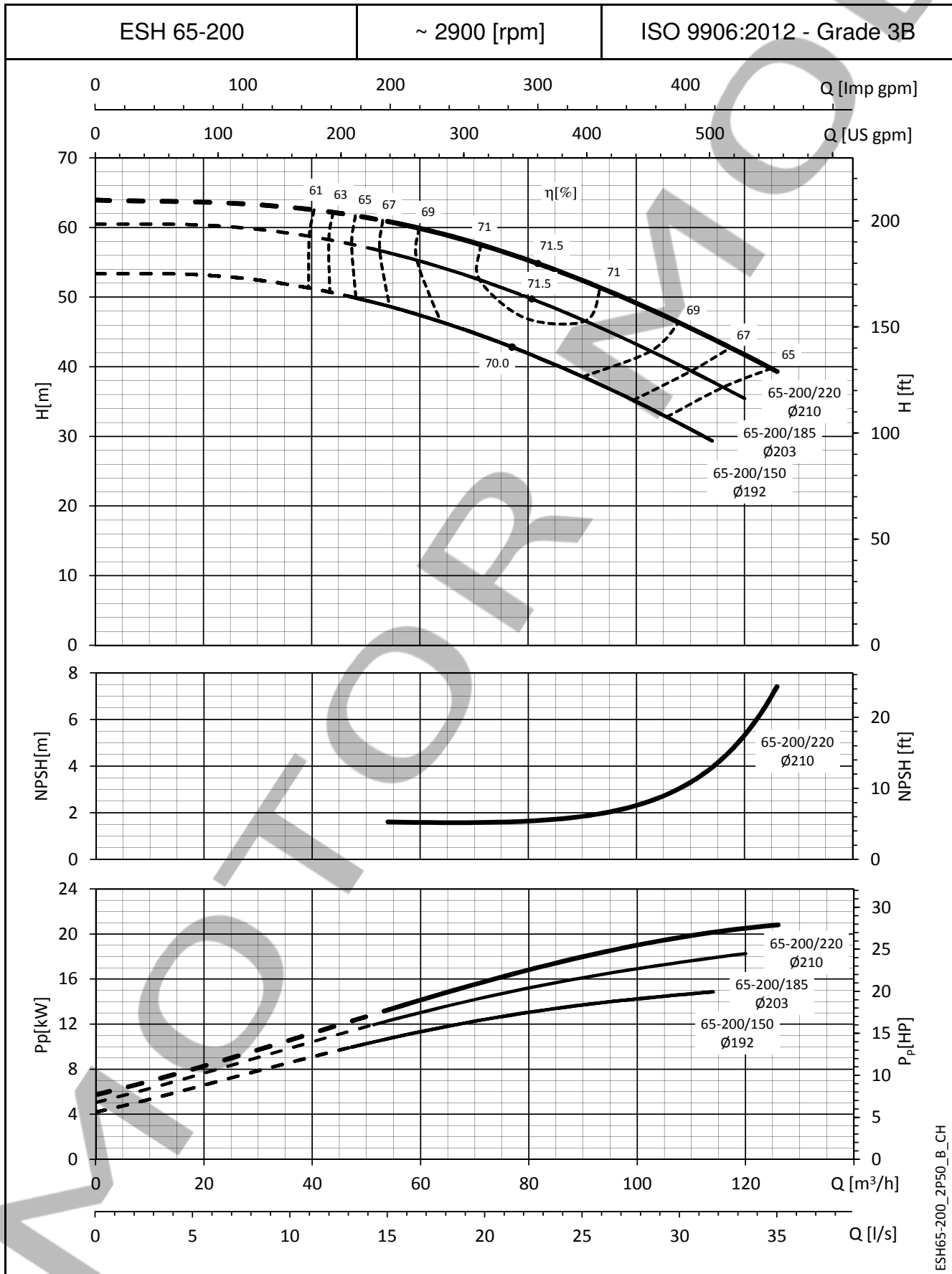

ESH65-200_2P50_B_CH

The NPSH values are laboratory values; for practical use we suggest increasing these values by 0,5 m.
These performances are valid for liquids with density $\rho = 1,0 \text{ Kg/dm}^3$ and kinematic viscosity $\nu = 1 \text{ mm}^2/\text{sec}$.

ESH SERIES
OPERATING CHARACTERISTICS AT 50 Hz, 2 POLES

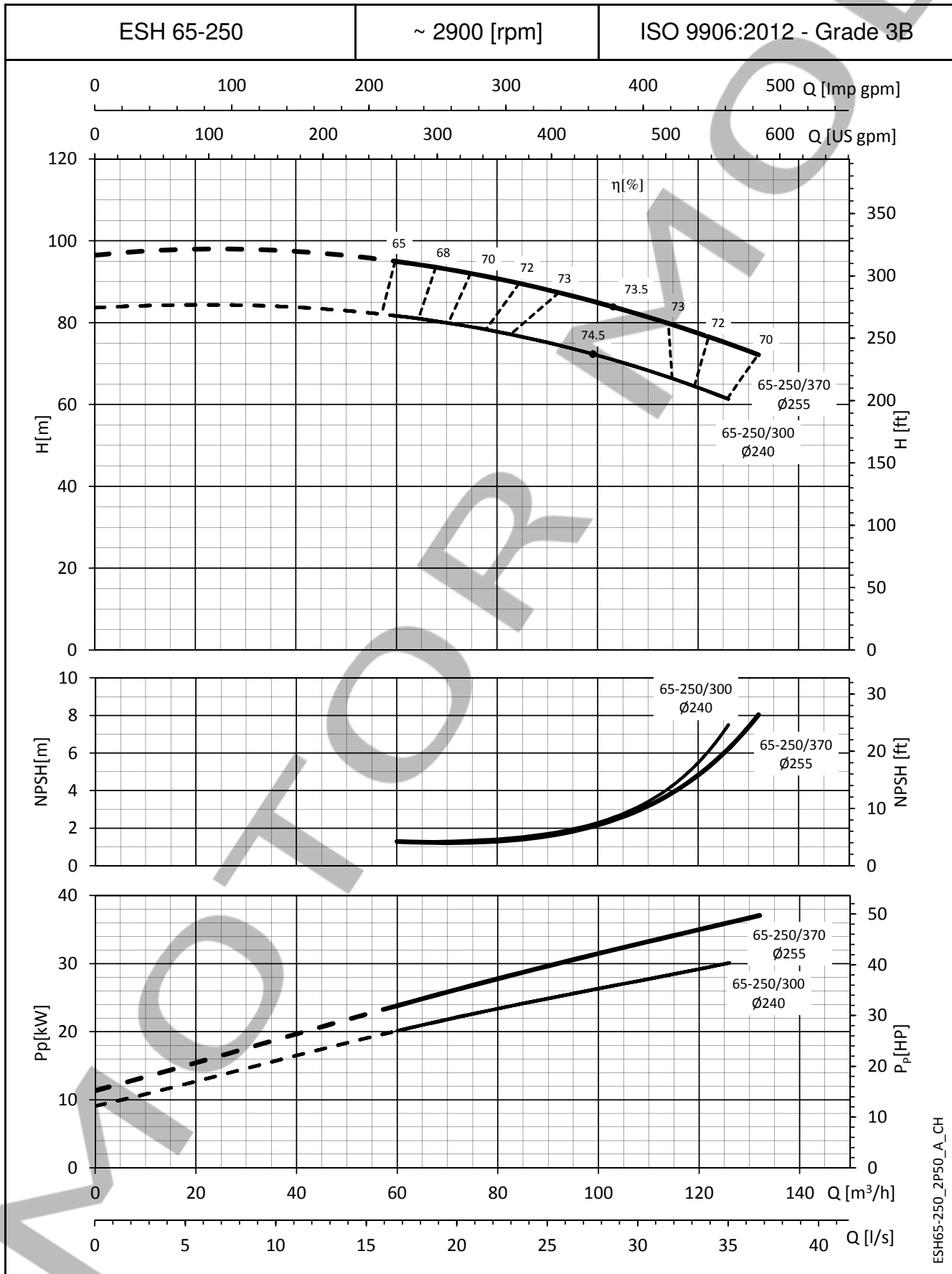

ESH65-250_2P50_A_CH

The NPSH values are laboratory values; for practical use we suggest increasing these values by 0,5 m.
These performances are valid for liquids with density $\rho = 1,0 \text{ Kg/dm}^3$ and kinematic viscosity $\nu = 1 \text{ mm}^2/\text{sec}$.

**ESHF SERIES
DIMENSIONS AND WEIGHTS AT 50 Hz, 2 POLES**

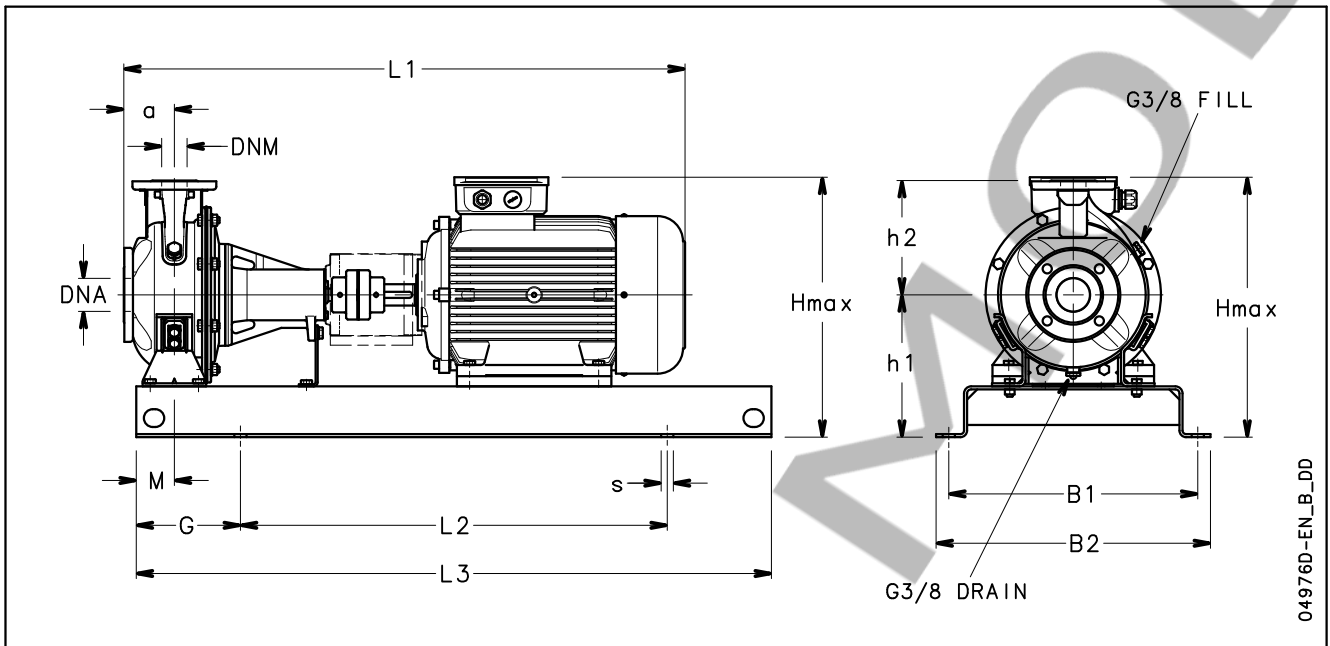

ESHF SERIES DIMENSIONS AND WEIGHTS AT 50 Hz, 2 POLES

PUMP TYPE ESHF..2	DIMENSIONS (mm)													s FOR SCREWS	WEIGHT kg	COUPLING TYPE
	DNM	DNA	a	B1	B2	L1	L2	L3	G	M	h1	h2	Hmax			
25-125/07/S	25	50	80	320	360	746	540	800	130	60	212	140	352	M16	67	A2
25-125/11/S	25	50	80	320	360	746	540	800	130	60	212	140	352	M16	69	A2
25-160/15/P	25	50	80	350	390	791	600	900	150	60	232	160	392	M16	73	A3
25-160/22/P	25	50	80	350	390	791	600	900	150	60	232	160	392	M16	75	A3
25-200/30/P	25	50	80	350	390	822	600	900	150	60	260	180	440	M16	95	B1
25-200/40/P	25	50	80	350	390	825	600	900	150	60	260	180	440	M16	97	B1
25-250/55/P	25	50	100	440	490	910	740	1120	190	75	280	225	505	M20	130	C1
25-250/75/P	25	50	100	440	490	910	740	1120	190	75	280	225	505	M20	134	C1
25-250/110/P	25	50	100	490	540	1067	840	1250	205	75	280	225	520	M20	181	C2
32-125/07/S	32	50	80	320	360	746	540	800	130	60	212	140	352	M16	67	A2
32-125/11/S	32	50	80	320	360	746	540	800	130	60	212	140	352	M16	69	A2
32-160/15/P	32	50	80	350	390	791	600	900	150	60	232	160	392	M16	73	A3
32-160/22/P	32	50	80	350	390	791	600	900	150	60	232	160	392	M16	75	A3
32-200/30/P	32	50	80	350	390	822	600	900	150	60	260	180	440	M16	95	B1
32-200/40/P	32	50	80	350	390	825	600	900	150	60	260	180	440	M16	97	B1
32-250/55/P	32	50	100	440	490	910	740	1120	190	75	280	225	505	M20	130	C1
32-250/75/P	32	50	100	440	490	910	740	1120	190	75	280	225	505	M20	134	C1
32-250/110/P	32	50	100	490	540	1067	840	1250	205	75	280	225	520	M20	181	C2
40-125/11/S	40	65	80	350	390	746	600	900	150	60	212	140	352	M16	70	A2
40-125/15/P	40	65	80	350	390	791	600	900	150	60	212	140	352	M16	74	A3
40-125/22/P	40	65	80	350	390	791	600	900	150	60	212	140	352	M16	77	A3
40-160/30/P	40	65	80	350	390	822	600	900	150	60	232	160	392	M16	92	B1
40-160/40/P	40	65	80	350	390	825	600	900	150	60	232	160	400	M16	96	B1
40-200/55/P	40	65	100	400	450	910	660	1000	170	60	260	180	451	M20	123	C1
40-200/75/P	40	65	100	400	450	910	660	1000	170	60	260	180	451	M20	128	C1
40-250/110A/P	40	65	100	490	540	1067	840	1250	205	75	280	225	520	M20	167	C2
40-250/110/P	40	65	100	490	540	1067	840	1250	205	75	280	225	520	M20	170	C2
40-250/150/P	40	65	100	490	540	1067	840	1250	205	75	280	225	520	M20	175	C2
50-125/22/P	50	65	100	350	390	811	600	900	150	60	232	160	392	M16	84	A3
50-125/30/P	50	65	100	350	390	842	600	900	150	60	232	160	392	M16	92	B1
50-125/40/P	50	65	100	350	390	845	600	900	150	60	232	160	400	M16	95	B1
50-160/55/P	50	65	100	400	450	910	660	1000	170	60	260	180	451	M20	120	C1
50-160/75/P	50	65	100	400	450	910	660	1000	170	60	260	180	451	M20	122	C1
50-200/110A/P	50	65	100	440	490	1067	740	1120	190	60	260	200	500	M20	145	C2
50-200/110/P	50	65	100	440	490	1067	740	1120	190	60	260	200	500	M20	150	C2
50-250/150/P	50	65	100	490	540	1067	840	1250	205	75	280	225	520	M20	165	C2
50-250/185/P	50	65	100	490	540	1067	840	1250	205	75	280	225	520	M20	170	C2
50-250/220/W	50	65	100	490	540	1127	840	1250	205	75	280	225	559	M20	272	D1
65-160/40/P	65	80	100	400	450	845	660	1000	170	75	260	200	460	M20	133	B1
65-160/55/P	65	80	100	440	490	910	740	1120	190	75	260	200	460	M20	155	C1
65-160/75/P	65	80	100	440	490	910	740	1120	190	75	260	200	460	M20	159	C1
65-160/110A/P	65	80	100	490	540	1067	840	1250	205	75	260	200	500	M20	162	C2
65-160/110/P	65	80	100	490	540	1067	840	1250	205	75	260	200	500	M20	162	C2
65-200/150/P	65	80	100	490	540	1067	840	1250	205	75	280	225	520	M20	185	C2
65-200/185/P	65	80	100	490	540	1067	840	1250	205	75	280	225	520	M20	190	C2
65-200/220/W	65	80	100	490	540	1127	840	1250	205	75	280	225	559	M20	265	D1
65-250/300/W	65	80	100	550	610	1340	940	1400	230	90	310	250	627	M24	359	E1
65-250/370/W	65	80	100	550	610	1340	940	1400	230	90	310	250	627	M24	375	E1
80-160/110/P	80	100	125	490	540	1092	840	1250	205	75	280	225	520	M20	198	C2
80-160/150/P	80	100	125	490	540	1092	840	1250	205	75	280	225	520	M20	209	C2
80-160/185/P	80	100	125	490	540	1092	840	1250	205	75	280	225	520	M20	220	C2
80-200/220/W	80	100	125	490	540	1262	840	1250	205	75	280	250	559	M20	278	D2
80-200/300/W	80	100	125	550	610	1365	940	1400	230	75	310	250	627	M24	359	E1
80-200/370/W	80	100	125	550	610	1365	940	1400	230	75	310	250	627	M24	375	E1
80-250/450/W	80	100	125	550	610	1454	940	1400	230	90	365	280	749	M24	549	E1
80-250/550/W	80	100	125	600	660	1563	1060	1600	270	90	390	280	792	M24	702	F1
80-250/750/W	80	100	125	670	730	1670	1200	1800	300	90	420	280	892	M24	979	G1