

50 Hz



e-SH Series

HORIZONTAL CENTRIFUGAL ELECTRIC PUMPS ACCORDING TO EN 733
MADE IN AISI 316 STAINLESS STEEL AND EQUIPPED WITH **IE3** MOTORS

ErP 2009/125/EC

Cod. 191002961 Rev. C Ed.07/2016

 **LOWARA**
a xylem brand

ESH 25, 32, 40, 50 SERIES HYDRAULIC PERFORMANCE RANGE AT 50 Hz, 4 POLES

PUMP TYPE	P _N kW	Ø Impeller (mm)		Q = DELIVERY													
		○ ● (1)	η _p % (2)	l/s m ³ /h	0 3	0,8 5	1,4 5	1,7 6	1,9 7	2,2 8	2,5 9	3,1 11	3,3 12	3,6 13	3,9 14	4,2 15	4,4 16
H = TOTAL HEAD METRES COLUMN OF WATER																	
25-125/02A	0,25	114	○	56,1	4,0		3,5	3,2	2,9	2,5	2,1	1,3					
25-125/02	0,25	128	●	60,7	5,2		4,6	4,3	4,0	3,7	3,3	2,6					
25-160/02A	0,25	141	○	53,8	5,9		5,4	5,1	4,8	4,4	3,9	2,8	2,2				
25-160/02	0,25	154	●	56,6	7,4		6,9	6,7	6,4	6,0	5,6	4,5	3,9	3,3			
25-200/03	0,37	178,0	○	52,3	9,4		8,1	7,8	7,3	6,9	6,3	5,1	4,5	3,7			
25-200/05	0,55	195	●	54,5	12,0		10,8	10,5	10,1	9,7	9,2	8,2	7,5	6,9	6,2		
25-250/07	0,75	203	○	46,6	13,0		12,2	11,9	11,6	11,2	10,7	9,7	9,1	8,4	7,7	6,9	
25-250/11	1,1	223,5	○	46,6	16,4		15,8	15,5	15,1	14,6	14,1	12,9	12,3	11,6	10,8	10,1	9,3
25-250/15	1,5	244,5	●	46,7	20,4		19,5	19,2	18,9	18,5	18,0	17,0	16,3	15,7	14,9	14,1	13,3
32-125/02A	0,25	114	○	58,5	4,1		3,5	3,3	3,1	2,8	2,4	1,7	1,3				
32-125/02	0,25	128	●	63,3	5,2		4,6	4,4	4,1	3,8	3,5	2,8	2,4	2,0			
32-160/02A	0,25	141	○	55,2	6,0		5,5	5,2	4,9	4,5	4,1	3,2	2,6				
32-160/02	0,25	154	●	57,9	7,5		7,0	6,7	6,4	6,1	5,7	4,8	4,3	3,8	3,2	2,6	
32-200/03	0,37	178	○	53,7	9,4		8,2	7,9	7,5	7,1	6,6	5,5	4,9	4,3			
32-200/05	0,55	195	●	53,9	12,0		10,8	10,5	10,1	9,6	9,1	8,0	7,4	6,8	6,1	5,3	
32-250/07	0,75	203	○	47,7	13,1		12,3	12,0	11,7	11,3	10,9	9,9	9,3	8,7	8,0	7,3	
32-250/11	1,1	223,5	○	47,7	16,4		15,9	15,6	15,3	14,8	14,4	13,2	12,6	11,9	11,2	10,4	9,6
32-250/15	1,5	244,5	●	48,2	20,4		19,6	19,3	19,0	18,6	18,2	17,3	16,7	16,1	15,4	14,7	13,9

PUMP TYPE	P _N kW	Ø Impeller (mm)		Q = DELIVERY													
		○ ● (1)	η _p % (2)	l/s m ³ /h	0 8	2,2 10	2,8 10	3,1 11	3,6 13	4,2 15	4,4 16	5,0 18	5,3 19	5,8 21	6,4 23	6,7 24	6,9 25
H = TOTAL HEAD METRES COLUMN OF WATER																	
40-125/02A	0,25	125	○	69,2	4,9	4,3	4,0	3,8	3,5	3,1	2,9	2,4	2,2	1,7			
40-125/02	0,25	133	●	68,1	5,7		4,9	4,7	4,4	4,0	3,8	3,4	3,2	2,7	2,2	1,9	
40-160/03	0,37	152	○	61,4	7,4	6,6	6,2	6,0	5,5	5,0	4,7	4,1	3,8	3,2	2,5	2,2	
40-160/05	0,55	171	●	66,5	9,2		8,3	8,1	7,7	7,2	7,0	6,4	6,1	5,5	4,8	4,4	4,0
40-200/07	0,75	190	○	64,3	11,9		11,0	10,8	10,3	9,7	9,3	8,6	8,2	7,3	6,3	5,8	
40-200/11	1,1	209	●	62,9	14,2		13,1	12,9	12,4	11,8	11,5	10,8	10,4	9,5	8,5	8,0	7,4
40-250/11	1,1	218	○	55,8	15,6		14,4	14,2	13,7	13,0	12,7	11,9	11,4	10,3			
40-250/15	1,5	233	○	57,0	18,1		16,8	16,6	16,1	15,5	15,2	14,4	14,0	13,1	12,0	11,4	
40-250/22	2,2	251	●	58,1	21,5		20,1	19,9	19,4	18,8	18,4	17,7	17,3	16,4	15,4	14,8	14,2

PUMP TYPE	P _N kW	Ø Impeller (mm)		Q = DELIVERY													
		○ ● (1)	η _p % (2)	l/s m ³ /h	0 15	4,2 18	5,0 18	5,6 20	6,4 23	7,2 26	8,1 29	8,6 31	9,4 34	10,3 37	11,1 40	11,7 42	12,5 45
H = TOTAL HEAD METRES COLUMN OF WATER																	
50-125/02	0,25	114	○	70,9	4,2	3,6	3,3	3,1	2,7	2,4	2,0	1,7	1,3	0,9			
50-125/03	0,37	123	○	72,5	4,9		4,2	4,0	3,6	3,2	2,8	2,6	2,1	1,7	1,2		
50-125/05	0,55	131	●	72,2	6,0		5,3	5,1	4,8	4,4	4,0	3,7	3,3	2,9	2,5	2,2	1,7
50-160/07	0,75	158	○	71,3	8,2		7,3	7,1	6,8	6,4	6,0	5,7	5,3	4,8	4,2	3,8	
50-160/11	1,1	174	●	73,0	9,8		8,8	8,6	8,3	7,9	7,6	7,3	6,9	6,4	5,8	5,4	4,8
50-200/11	1,1	197	○	69,1	12,8		11,2	10,8	10,2	9,6	8,8	8,3	7,4	6,5	5,5	4,8	
50-200/15	1,5	209	●	70,1	14,7		13,0	12,7	12,1	11,4	10,6	10,1	9,3	8,3	7,3	6,6	5,5
50-250/22A	2,2	224	○	70,0	17,4		16,0	15,7	15,2	14,6	14,0	13,5	12,7	11,7	10,6	9,7	
50/250/22	2,2	237	○	69,0	19,4		17,8	17,5	17,0	16,4	15,7	15,2	14,4	13,5	12,4	11,6	
50-250/30	3	250	●	67,9	21,9		20,6	20,3	19,8	19,2	18,6	18,1	17,3	16,4	15,4	14,7	13,5

Hydraulic performances in compliance with ISO 9906:2012 - Grade 3B (ex ISO 9906:1999 - Annex A)

ESH-25-32-40-50_4p50-en_c_th

(1) ● = Full impeller diameter - ○ = Trimmed impeller diameter (2) Hydraulic efficiency of pump.

ESH SERIES
OPERATING CHARACTERISTICS AT 50 Hz, 4 POLES

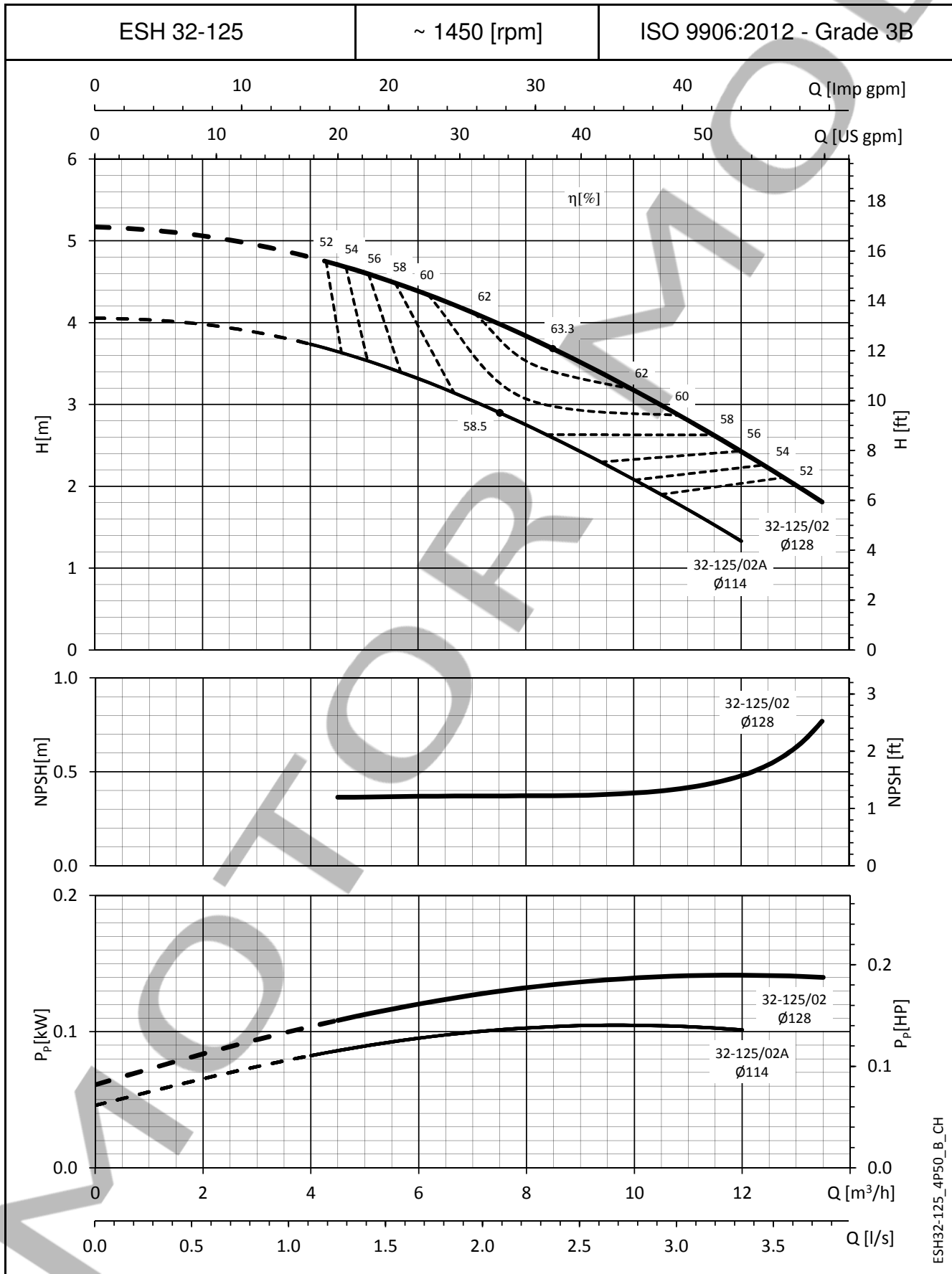

ESH32-125_4P50_B_CH

The NPSH values are laboratory values; for practical use we suggest increasing these values by 0,5 m.
These performances are valid for liquids with density $\rho = 1,0 \text{ Kg/dm}^3$ and kinematic viscosity $\nu = 1 \text{ mm}^2/\text{sec}$.

ESH SERIES
OPERATING CHARACTERISTICS AT 50 Hz, 4 POLES

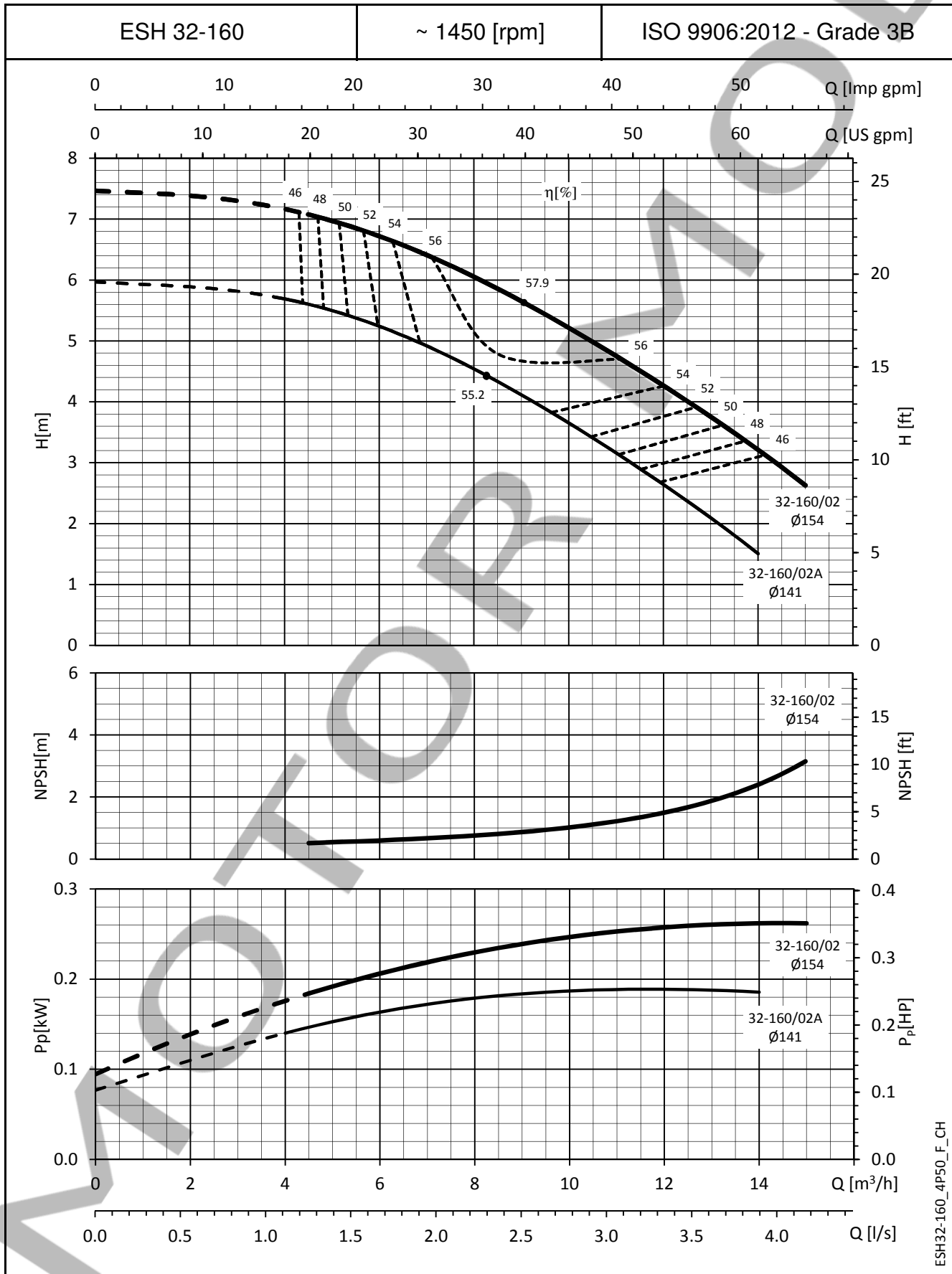

ESH32-160_4P50_F_CH

The NPSH values are laboratory values; for practical use we suggest increasing these values by 0,5 m.
These performances are valid for liquids with density $\rho = 1,0 \text{ Kg/dm}^3$ and kinematic viscosity $\nu = 1 \text{ mm}^2/\text{sec}$.

ESH SERIES
OPERATING CHARACTERISTICS AT 50 Hz, 4 POLES

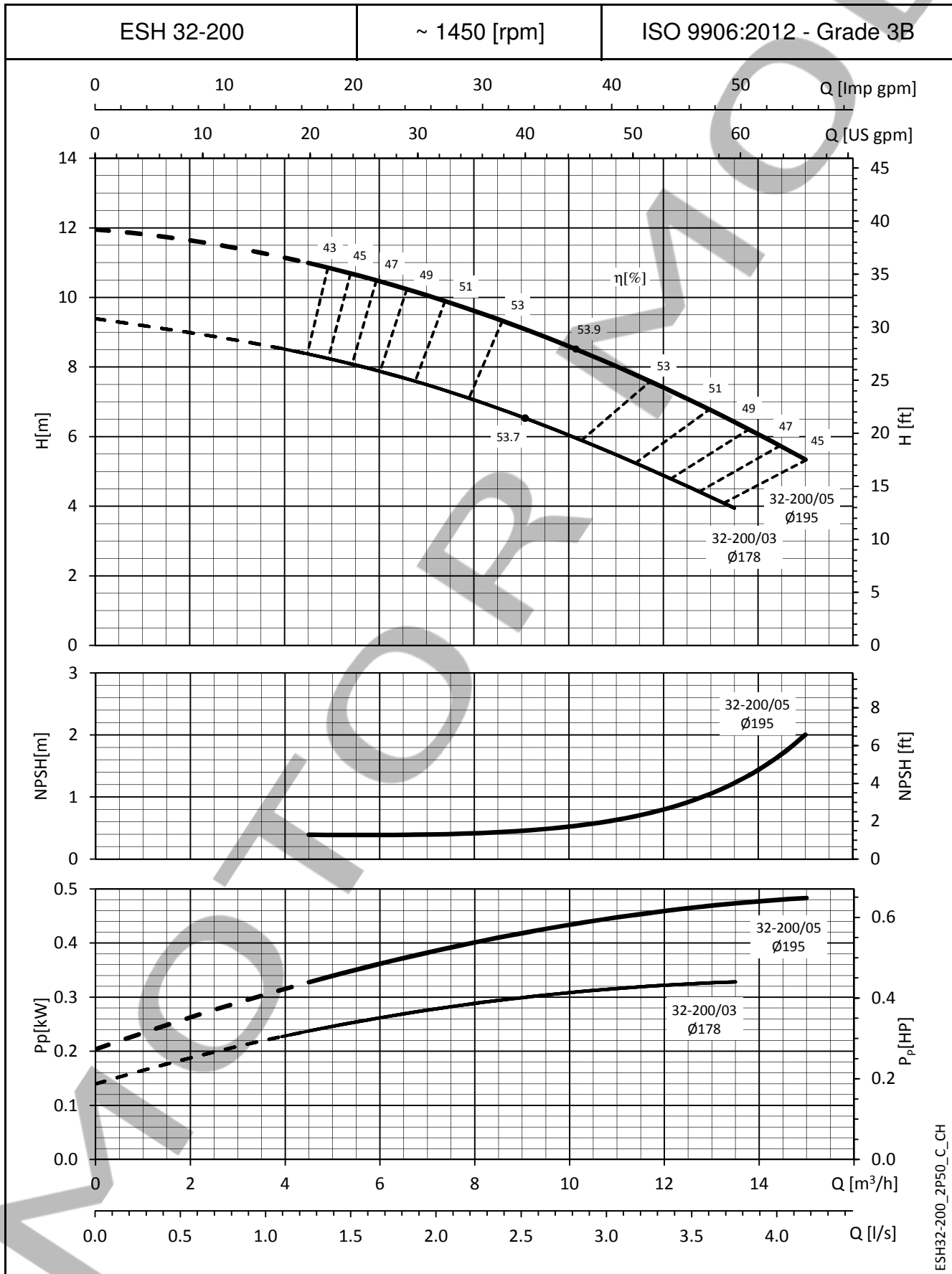

ESH32-200_2P50_C_CH

The NPSH values are laboratory values; for practical use we suggest increasing these values by 0,5 m.
These performances are valid for liquids with density $\rho = 1,0 \text{ Kg/dm}^3$ and kinematic viscosity $\nu = 1 \text{ mm}^2/\text{sec}$.

ESH SERIES
OPERATING CHARACTERISTICS AT 50 Hz, 4 POLES

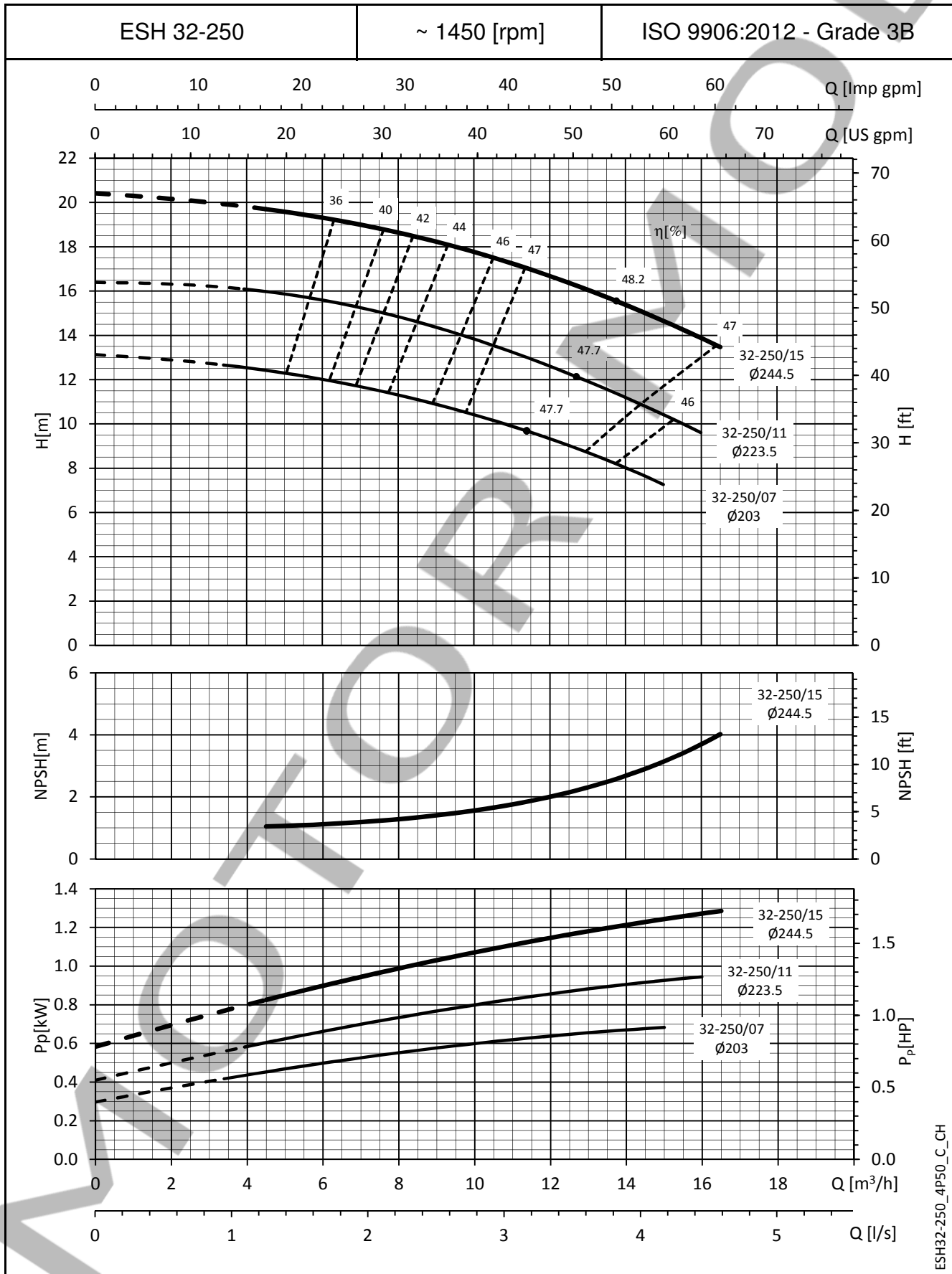

ESH32-250_4P50_C_CH

The NPSH values are laboratory values; for practical use we suggest increasing these values by 0,5 m.
These performances are valid for liquids with density $\rho = 1,0 \text{ Kg/dm}^3$ and kinematic viscosity $\nu = 1 \text{ mm}^2/\text{sec}$.

**ESHF SERIES
DIMENSIONS AND WEIGHTS AT 50 Hz, 4 POLES**

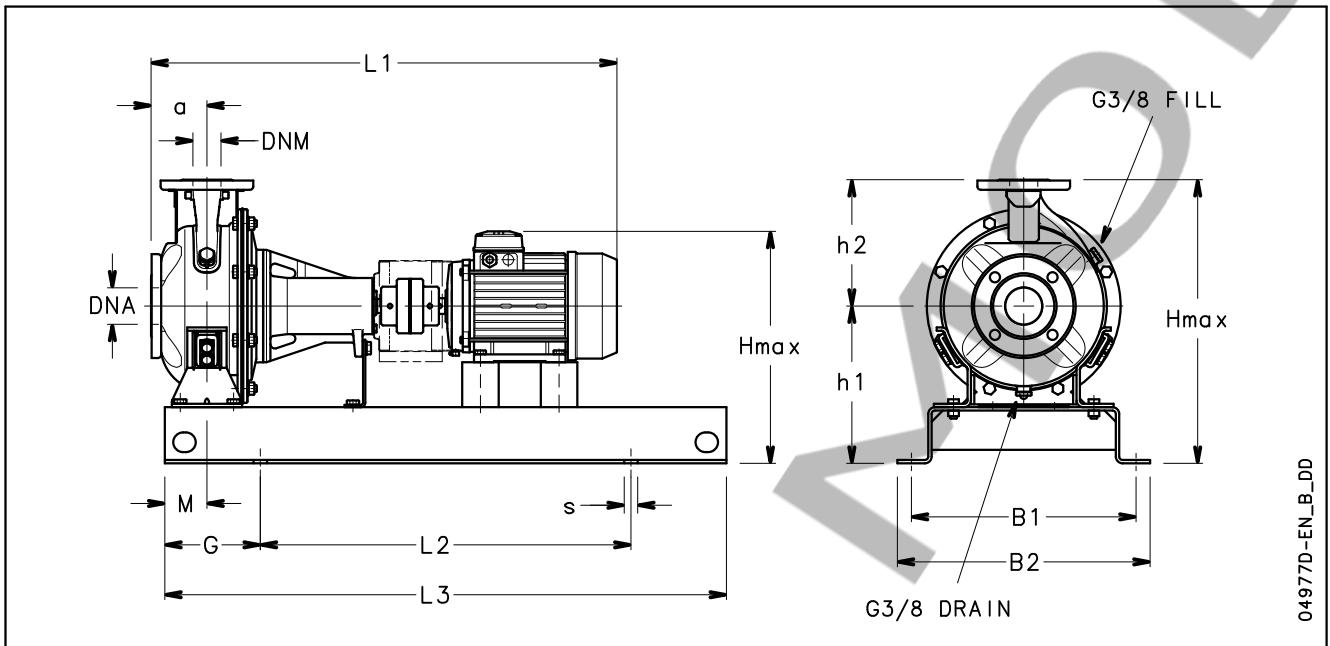

04977D-EN_B_DD

MOTOR

ESHF SERIES DIMENSIONS AND WEIGHTS AT 50 Hz, 4 POLES

PUMP TYPE ESHF..4	DIMENSIONS (mm)													s FOR SCREWS	WEIGHT kg	COUPLING TYPE
	DNM	DNA	a	B1	B2	L1	L2	L3	G	M	h1	h2	Hmax			
25-125/02A/S	25	50	80	320	360	704	540	800	130	60	212	140	352	M16	72	A1
25-125/02/S	25	50	80	320	360	704	540	800	130	60	212	140	352	M16	72	A1
25-160/02A/S	25	50	80	320	360	704	540	800	130	60	232	160	392	M16	74	A1
25-160/02/S	25	50	80	320	360	704	540	800	130	60	232	160	392	M16	74	A1
25-200/03/S	25	50	80	320	360	704	540	800	130	60	260	180	440	M16	78	A1
25-200/05/S	25	50	80	320	360	746	540	800	130	60	260	180	440	M16	80	A2
25-250/07/X	25	50	100	400	450	734	660	1000	170	75	280	225	505	M20	98	A2
25-250/11/P	25	50	100	400	450	811	660	1000	170	75	280	225	505	M20	106	A3
25-250/15/P	25	50	100	400	450	811	660	1000	170	75	280	225	505	M20	108	A3
32-125/02A/S	32	50	80	320	360	704	540	800	130	60	212	140	352	M16	72	A1
32-125/02/S	32	50	80	320	360	704	540	800	130	60	212	140	352	M16	72	A1
32-160/02A/S	32	50	80	320	360	704	540	800	130	60	232	160	392	M16	74	A1
32-160/02/S	32	50	80	320	360	704	540	800	130	60	232	160	392	M16	74	A1
32-200/03/S	32	50	80	320	360	704	540	800	130	60	260	180	440	M16	78	A1
32-200/05/S	32	50	80	320	360	746	540	800	130	60	260	180	440	M16	80	A2
32-250/07/X	32	50	100	400	450	734	660	1000	170	75	280	225	505	M20	98	A2
32-250/11/P	32	50	100	400	450	811	660	1000	170	75	280	225	505	M20	106	A3
32-250/15/P	32	50	100	400	450	811	660	1000	170	75	280	225	505	M20	108	A3
40-125/02A/S	40	65	80	320	360	704	540	800	130	60	212	140	352	M16	57	A1
40-125/02/S	40	65	80	320	360	704	540	800	130	60	212	140	352	M16	57	A1
40-160/03/S	40	65	80	320	360	704	540	800	130	60	232	160	392	M16	60	A1
40-160/05/S	40	65	80	320	360	746	540	800	130	60	232	160	392	M16	62	A2
40-200/07/X	40	65	100	350	390	734	600	900	150	60	260	180	440	M16	70	A2
40-200/11/P	40	65	100	350	390	811	600	900	150	60	260	180	440	M16	78	A3
40-250/11/P	40	65	100	400	450	811	660	1000	170	75	280	225	505	M20	105	A3
40-250/15/P	40	65	100	400	450	811	660	1000	170	75	280	225	505	M20	108	A3
40-250/22/P	40	65	100	400	450	888	660	1000	170	75	280	225	505	M20	131	B1
50-125/02/S	50	65	100	320	360	724	540	800	130	60	232	160	392	M16	59	A1
50-125/03/S	50	65	100	320	360	724	540	800	130	60	232	160	392	M16	59	A1
50-125/05/S	50	65	100	320	360	766	540	800	130	60	232	160	392	M16	61	A2
50-160/07/X	50	65	100	350	390	734	600	900	150	60	260	180	440	M16	69	A2
50-160/11/P	50	65	100	350	390	811	600	900	150	60	260	180	440	M16	77	A3
50-200/11/P	50	65	100	350	390	811	600	900	150	60	260	200	460	M16	88	A3
50-200/15/P	50	65	100	350	390	811	600	900	150	60	260	200	460	M16	91	A3
50-250/22A/P	50	65	100	400	450	888	660	1000	170	75	280	225	505	M20	132	B1
50-250/22/P	50	65	100	400	450	888	660	1000	170	75	280	225	505	M20	132	B1
50-250/30/P	50	65	100	400	450	888	660	1000	170	75	280	225	505	M20	136	B1
65-160/05/S	65	80	100	350	390	766	600	900	150	75	260	200	460	M16	84	A2
65-160/07/X	65	80	100	350	390	734	600	900	150	75	260	200	460	M16	86	A2
65-160/11A/P	65	80	100	400	450	811	600	1000	170	75	260	200	460	M20	94	A3
65-160/11/P	65	80	100	400	450	811	660	1000	170	75	260	200	460	M20	94	A3
65-160/15/P	65	80	100	400	450	811	660	1000	170	75	260	200	460	M20	97	A3
65-200/15/P	65	80	100	400	450	811	660	1000	170	75	280	225	505	M20	109	A3
65-200/22/P	65	80	100	440	490	888	740	1120	190	75	280	225	505	M20	133	B1
65-200/30/P	65	80	100	440	490	888	740	1120	190	75	280	225	505	M20	137	B1
65-250/40/P	65	80	100	440	490	1031	740	1120	190	90	310	250	550	M20	178	C3
65-250/55/P	65	80	100	440	490	1058	740	1120	190	90	310	250	550	M20	193	C4
80-160/15/P	80	100	125	400	450	836	660	1000	170	75	280	225	505	M20	127	A3
80-160/22A/P	80	100	125	440	490	913	740	1120	190	75	280	225	505	M20	143	B1
80-160/22/P	80	100	125	440	490	913	740	1120	190	75	280	225	505	M20	143	B1
80-200/30/P	80	100	125	440	490	1023	740	1120	190	75	280	250	530	M20	162	C3
80-200/40/P	80	100	125	440	490	1056	740	1120	190	75	280	250	530	M20	171	C3
80-250/55/P	80	100	125	490	540	1083	840	1250	205	90	310	280	590	M20	194	C4
80-250/75/P	80	100	125	490	540	1083	840	1250	205	90	310	280	590	M20	198	C4
80-250/110/P	80	100	125	490	540	1202	840	1250	205	90	310	280	590	M20	256	C5